



Raleigh

Invitation to Bid (ITB)

#274-2025-15-JEJ

Title: SIGNS, BLANKS & POSTS

Notice is hereby given that the City of Raleigh, North Carolina, is seeking sealed bids for **SIGNS, BLANKS & POSTS**. A contract will be awarded for a term of one year with renewal options for up to three (3) additional twelve (12) month terms, subject to contract performance and an annual appropriation by the Raleigh City Council.

BIDS WILL BE ACCEPTED UNTIL 2:00 PM (EDT), Tuesday, February 4th, 2025

Bids should be addressed to:

City of Raleigh

Finance Dept - Procurement Division

Attn: Eric Johnson – Procurement Analyst

Hand-Deliver to: 222 W. Hargett Street, 5th Floor, Ste. 502, Raleigh, NC 27601

or

Mail to: PO Box 590, Raleigh, NC 27602-0590

PUBLIC BID OPENING WILL BE HELD AT THE RALEIGH MUNICIPAL BUILDING, 222 W. Hargett Street., RM 503, Raleigh, North Carolina, at 2:00PM EST ON TUESDAY, FEBRUARY 4, 2025.

The responsibility for submitting a response to this ITB at the City of Raleigh, Procurement Division on or before the stipulated time and date will be solely and strictly the responsibility of the bidder. Any proposals received after stipulated time and date will not be accepted, nor opened, and will be returned. The time stamp located in the Procurement Division shall be the official time of receipt.

BID RESPONSE FORM

Bid No.: 274-2025-15-JEJ
Bid Title: Signs, Blanks & Posts

Pursuant to General Statutes of North Carolina, Section 143-129, as amended, sealed bids are invited and, subject to the conditions herein, will be received by the City of Raleigh Procurement Division. The sealed bids will be publicly opened for furnishing the apparatus, supplies, materials equipment and/or repair work and services as described herein.

In compliance with this Invitation for Bids, and subject to all the conditions thereof, the undersigned Supplier offers and agrees, if this bid be accepted, to furnish and deliver any or all items upon which prices are bid, at the prices set opposite each item within the time specified herein. By executing this bid, the undersigned Supplier certifies that this bid is submitted competitively and without collusion. Furthermore, by executing this bid, the undersigned certifies to the best of Supplier's knowledge and belief, that it and its principals are not presently debarred, suspended, proposed for debarment, declared ineligible or voluntarily excluded from covered transactions by any Federal or State department or agency.

Failure to execute/sign bid prior to submittal shall render the bid invalid, and it WILL BE DEEMED NON-RESPONSIVE and WILL BE REJECTED. Late bids cannot be accepted.

SUPPLIER NAME:		
STREET ADDRESS:		
CITY & STATE:	STATE:	ZIP CODE:
PRINT NAME & TITLE OF PERSON SIGNING ON BEHALF OF SUPPLIER:		
SUPPLIER'S AUTHORIZED SIGNATURE:	DATE:	
CONTACT NAME (if different from above):		
EMAIL ADDRESS:	TELEPHONE NUMBER:	

OFFER VALID FOR AT LEAST 90 DAYS FROM DATE OF BID

OPENING ACCEPTANCE OF BID

If any or all parts of this bid are accepted by the City of Raleigh, this document and all provisions of this Invitation to Bid along with the Supplier's bid response shall then constitute the written agreement between the parties.

CITY OF RALEIGH
NON-DISCRIMINATION ASSURANCES

To the extent permitted by North Carolina law, the parties hereto for themselves, their agents, officials, employees and servants agree not to discriminate in any manner on the basis of race, color, creed, national origin, sex, age, handicap, or sexual orientation with reference to the subject matter of this Contract. The parties further agree, to the extent permitted by law, to conform with the provisions and intent of City of Raleigh Ordinance 1969-889, as amended. This provision is hereby incorporated into this Contract for the benefit of the City of Raleigh and its residents, and may be enforced by action for specific performance, injunctive relief, or other remedy as provided by law. This provision shall be binding on the successors and assigns of the parties with reference to the subject matter of this Contract.

SIGNATURE: _____
(President/Authorized Officer)

TITLE: _____

DATE: _____

**City of Raleigh
SIGNS, BLANKS & POSTS
BID No: 274-2025-15-JEJ**

BID PRICE FORM

	DESCRIPTION	ESTIMATED ANNUAL QUANTITY	TOTAL PRICE
	GROUP 1 – METAL POSTS	See Price Sheet	\$ _____
	GROUP 2 – SIGN BLANKS	See Price Sheet	\$ _____
	GROUP 3 – SIGN FACES	See Price Sheet	\$ _____
	GROUP 4 – SHEETING	See Price Sheet	\$ _____
	GROUP 5 – BOLTS	See Price Sheet	\$ _____
TOTAL PRICE FOR ALL GROUPS:			\$ _____ FOB DESTINATION, RALEIGH, NC

NOTICE TO BIDDERS: Do not include taxes in your bid pricing. Any and all tax imposed upon any article on which you are bidding are only to be shown as separate line items on invoices, and in no case are taxes to be included with your bid price. Failure to comply with these conditions will be considered grounds for rejection.

EMAIL AND FAX COPIES OF BIDS ARE NOT ACCEPTABLE

NO BIDS CONSIDERED UNLESS SUBMITTED ON THIS FORM

COMPANY: _____

DATE: _____

AUTHORIZED SIGNATURE: _____

TITLE: _____

CITY OF RALEIGH INSTRUCTIONS TO BIDDERS

Carefully review all provisions and attachments of this document prior to completion. Each bid constitutes an offer and may not be withdrawn except as provided herein.

1. PURPOSE:

The purpose of this document is to provide general and specific information for the use by suppliers in submitting a bid to supply the City of Raleigh with apparatus, supplies, material and equipment, and /or services listed above. All bids and contracts are governed by City policy, and /or by Section 143-129 of the North Carolina General Statutes.

2. BID CONTACT:

Any and all questions, concerns, or request for additional information shall be directed to the City of Raleigh, Procurement Division to the attention of the Bid Agent as indicated below:

Bid Agent: Eric Johnson
Procurement Analyst
Email: Eric.Johnson@raleighnc.gov

3. BID SCHEDULE:

Listed below are the dates and times by which stated actions must be taken or completed. The City may determine, in its sole discretion, that it is necessary to change any of these dates and times. All listed times are Eastern Standard Times.

Action	Time	Date
Bid issued	NA	January 27, 2025
Pre-Bid Conference	NA	NA
Deadline for Questions	12:00 p.m.	January 29, 2025
Bids Due	2:00 p.m.	February 4, 2025
Anticipated Award		

4. PRE-BID CONFERENCE:

If a pre-bid meeting is scheduled, the pre-bid meeting will be held at the time and place as stated above to discuss the specifications. Attendance at the pre-bid meeting is **not mandatory** for submitting a bid; however, it is highly encouraged.

Questions or information needed for clarification may be emailed prior to the pre-bid meeting to the Bid Agent as indicated in Section 2 above or presented in writing at the pre-bid meeting. All items of concern will be discussed at the pre-bid meeting. Any changes to the specifications will be made in the form of an addendum and posted to the North Carolina electronic Vendor Portal (eVP) website: <https://evp.nc.gov/>

5. BIDDER QUESTIONS:

The City is not liable for interpretations/misinterpretations or other errors or omissions made by the Bidder in responding to this bid. The Bidder shall examine this bid to determine if the City’s requirements and terms and conditions are clearly stated. If, after examination of the various requirements and terms and conditions of this bid, the Bidder believes there are any requirements or terms and conditions which remain unclear or which restrict competition, the Bidder may request, in writing, that the City clarify the requirement(s) and terms(s) and condition(s) specified by the Bidder. The Bidder must provide the Section(s), Subsection(s), Paragraph(s), and page number(s) that identify the requirements or conditions questioned by the Bidder.

Requests for clarification and technical questions to this bid must be received by the City not later than the date shown above in Section 3, entitled “Bid Schedule”, for the submittal of written inquires. The Bidders’ failure to request clarification and submit questions by the date in the bid schedule above shall be considered to constitute the Bidders’ acceptance of all City’s requirements and terms and conditions. The City shall issue addenda reflecting questions and answers to this bid, if any, and shall be posted to the North Carolina electronic Vendor Portal (eVP) website: <https://evp.nc.gov/>

6. ADDENDUM:

Bidders are solely responsible for making sure that any and all addenda have been received prior to submission of their bid. The All addenda to this bid issued by the City shall be posted to the North Carolina electronic Vendor Portal (eVP) website:

<https://evp.nc.gov/> .

All such addenda shall become part of the bid. **Bidder is to sign any and all addenda issued for the bid and submit it with the bid.** Failure to do so risks rejection of the bid.

7. HOW TO PREPARE BID:

Bidders are encouraged to review carefully all provisions and attachments of this document prior to completion. Each bid constitutes an offer and may not be withdrawn except as provided herein. Also, prices are to remain firm for the period stated herein.

- a) **BID FORM:** Submit all prices and offers on the **BID FORM(s)** provided herein. All bid must be submitted and signed by the supplier or his authorized representative with all erasures or corrections initialed and dated by the authorized representative of the proposal.
- b) **SIGNATURE:** **All bids must be signed by an authorized official of the company on the Bidders Signature Page.** A bid may be rejected if it shows omissions, alterations of form, additions not called for, conditional bid, or any irregularities.
- c) **TAXES:** **Do not include taxes in your bid prices.** Taxes must be itemized and added to invoices separately when invoicing the City. The City is required to pay sales tax. The City is exempt from Federal Excise Tax and has a Federal Tax number.
- d) **NON-DISCRIMINATION:** The **NON-DISCRIMINATION ASSURANCES** form included in the bid package is a condition of the bid and must be completed and signed by the bidder.
- e) **MWBE POLICY:** The City of Raleigh prohibits discrimination in any manner on the basis of race, color, creed, national origin, sex, age or handicap or sexual orientation and will pursue an affirmative policy of fostering, promoting and conducting business with women and minority owned business enterprises. The City of Raleigh encourages participation by certified minority and women-owned businesses. If there are any questions, Contact the MWBE Program Manager, PO BOX 590 Raleigh, NC 27602, mwbe@raleighnc.gov, or 919-996-4330.
- f) **SUSTAINABILITY:** In accordance with the City of Raleigh 2007-2009 City Council Mission Statement, the City recognizes its responsibility to minimize negative impacts on human health and the environment while supporting a diverse, equitable, and vibrant community and economy. The City recognizes that the types of products and services the City buys have inherent social, human health, environmental and economic impacts, and asks that all Suppliers and bidders providing and proposing products and services to the City, be mindful of the City’s Sustainability Policy and provide and propose products and services that embody the City’s commitment to sustainability whenever possible.
- g) **IRAN DIVESTMENT:**
Bidder certifies that it is not on the Final Divestment List as created by the State Treasurer pursuant to N.C.G.S. § 147-86.55, et seq. In compliance with the requirements of the Iran Divestment Act and N.C.G.S. § 147-86.59, CONTRACTOR shall not utilize in the performance of the contract any subcontractor that is identified on the Final Divestment List.
- h) **COMPANIES THAT BOYCOTT ISRAEL:**
The bidder certifies that it has not been designated by the North Carolina State Treasurer as a company engaged in the boycott of Israel pursuant to N.C.G.S. 147-86.81.

8. HOW TO SUBMIT BID:

- a) **SUBMIT SEALED BIDS ON THE BID FORM PROVIDED HEREIN.**
- b) **Provide (2) complete set of your bid on the BID FORM PROVIDED HEREIN in hard copy paper format (on 8-1/2” x 11” size paper, only bound with a single staple in the upper left corner or with a single removable clip—no 3-ring binders) and must be SEALED in an envelope.**

NO EMAIL OR FAX BIDS WILL BE ACCEPTED. All Formal Bids (estimated to be greater than \$90,000) must be submitted in a sealed opaque envelope, plainly marked with the bid number, and date and time to be opened as shown below.

- c) All bids must be mailed or delivered as follows in sufficient time to ensure receipt by the Procurement Manager or Bid Agent on or before the time and the date specified on the Bid Form. Bids not received by the time and date specified on the Bid Form will not be opened or considered, unless the delay is a result of the negligence of the City of Raleigh, its agents, or assigns.

Mailing Address:
City of Raleigh
Bid# 274-2025-15-JEJ
Procurement Division
PO Box 590
Raleigh, NC 27602-0590

Delivery Address:
City of Raleigh
Bid# 274-2025-15-JEJ
Procurement Division
222 W. Hargett St., Room 502
Raleigh, NC 27601

- d) **Electronic responses** will not be accepted for this solicitation.

7. BID OPENING:

- a) A public bid opening will be held at 222 W. Hargett Street, 5th Floor, Ste. 502, Raleigh, NC 27601. No official award will be made at the Bid Opening. All bidders are welcome to attend the bid opening. **LATE BIDS WILL NOT BE OPENED OR ACCEPTED.**
- b) Bidders may not review or request copies of bids at the Bid Opening. A time must be scheduled to meet with the Procurement Manager and/or Bid Agent for this purpose.
- c) Bids will be examined by the Procurement Manager and/or Bid Agent and the using department officials promptly after the opening and an award made at the earliest possible date. No bids may be withdrawn after bid opening.

8. AWARD OF BID:

- a) **Standard of Bid Award Acceptance:** The City reserves the right to reject any or all bids and to waive any irregularities or technicalities in bids received whenever such rejection or waiver is in the best interest of the City of Raleigh. The award shall be made to the lowest, responsive, responsible bidder, or bidders, taking into consideration quality, performance and the time specified in the bid for the performance of the contract.
- b) **Bid Prices:** All items and products proposed in response to this Bid are to be new, in un-used condition unless otherwise noted in the Minimum Specifications. All prices proposed in response to this Bid are to include all transport, freight and fuel surcharges, and be delivered **FOB destination, freight prepaid and allowed** to the location provided on the City Purchase Order. All items are to be packaged, and shipped or delivered safely in a protective carton, fully assembled and serviced, ready for use and operation. Bidders must submit product literature and manufacturer’s specifications with their bid proposal. All supplies, equipment, and apparatus must meet all Federal, State, and Local safety regulations, requirements, and guidelines, such as OSHA, EPA, US DOT, NC-DOT, NFPA, UL, etc., if so regulated.
- c) **Order of Precedence:** In cases of conflict between sections and provisions within the Bid document, the Order of Precedence will be 1) the Special Conditions section specific to the Bid; 2) the Minimum Specifications section specific to the Bid, 3) the City of Raleigh Terms and Conditions; and 4) the Instructions to Bidders section of the Bid document.
- d) **Payment Terms:** Payment terms of Net 30 days from the date of receipt of invoice, or upon acceptance of goods whichever is later, will apply to all invoices. Payment term discounts will be allowed for prompt payments but will not be a consideration for award. All invoices are to be emailed to accountspayable@raleighnc.gov , or delivered to **City of Raleigh, Accounts Payable Division, PO Box 590, Raleigh, NC 27602-0590.**
- e) **Bid Award Approval:** The City Manager has delegated authority from the City Council to award bids for supplies, equipment, and apparatus greater than \$90,000. Bids will be approved and awarded by the City Manager upon the recommendation by the Procurement Manager.

9. OBJECTION TO THE SPECIFICATIONS:

It is not the intent of the bid specifications to exclude or limit competition or favor any particular supplier or product. If there is an objection to any of the specifications or requirements listed herein, the bidder must notify the City of Raleigh Procurement Manager, in writing, stating and listing the specifications and objections, no later than five (5) working days prior to the bid opening date. If a pre-bid meeting has been scheduled, any objections must be presented in writing at that time. The objections stated must pertain both to form and substance of the bid document. Failure to object in accordance with the above procedure shall constitute a waiver on the part of the bidder to protest the solicitation. All concerns, questions, clarifications, or other correspondence must be directed only to the City of Raleigh Procurement Manager. Information obtained from other sources will not be considered in the evaluation and award of this bid.

19. SUBMITTING A PROTEST TO THE BID AWARD:

A Bidder wishing to express a concern or complaint, and file a protest to a Bid Award, must submit in writing the reasons, information, and documentation for the protest, to the Procurement Manager within 48 hours (two business days) from the date of the Notice of Intent to Award. In the event of a protest, the Procurement Manager will notify the Chief Financial Officer and the City Manager of the protest and provide the information for both the recommended award and the protest. The City Manager will make

a final decision for the bid award. The protesting bidder may appeal the decision to the City Council.

20. FAILURE TO BID:

If the bid is not submitted, bidder should return the attached “NO BID RESPONSE” sheet, stating the reasons therefore, and indicate whether the business should be retained or removed from the City’s Bidder’s list.

21. ERRORS IN BIDS:

Bidders or their authorized representatives are expected to understand the conditions, requirements and specifications before submitting bids. Failure to do so will be at the bidders own risk. In case of an error in the extension of prices on the bid, the unit price shall govern.

22. ALTERNATE BIDS:

DO NOT submit alternate bids unless called for on the bid proposal form. Alternate bids are those that are not identical by manufacturer and model to what is specified or has substantially different specifications. When alternate bids are requested, the bidder must submit documentation as a part of the bid to show that the product is comparable to the item(s) referred to in the specifications. Bidders may submit multiple bids on various manufacturers’ brands/models meeting specifications if no specific manufacturer/model has been specified.

23. BID OPTIONS:

The City reserves the right to request pricing on optional equipment or additional items along with the pricing for the main or primary product or items. At the discretion of the City, some or all of the options requested may or may not be added and purchased based upon necessity and the availability of budgeted funds. The Bid Award will be made to the lowest responsible bidder for the main or primary product or items listed on the Bid Proposal Form. Pricing for any additional options will be requested in a separate section of the bid and will not be included in the determination of the Bid Award.

24. QUANTITIES:

The City of Raleigh reserves the right to adjust quantities as needed, and to add additional items and/or products as needed, as determined to be in the best interest of the City. The quantities stated herein, for term or multi-year contracts are estimated, and may change to be more or less over the term of the contract.

25. PRICE ADJUSTMENTS:

For Bids with fixed price contract periods, it is the City’s intent to contract at a fixed price for a period of one (1) year, with an option to extend the contract for three (3) additional one (1) year periods. The price proposed by the Bidder is to remain fixed for the first 1-year (12-month) period of the contract.

Any requested price increase must be fully documented and submitted to the Bid Agent or the Procurement Manager at least sixty (60) days prior to the bid contract expiration date. Any approved price adjustment (increase or decrease) will then become effective beginning the next term period.

The City reserves the right to accept or to refuse any documented price adjustment submitted by the Supplier/contractor for any reason as determined to be in the best interest of the City. In the event the City does not accept the proposed price adjustment for the extended term, the Bid contract will not be renewed, and the City will rebid the product or item(s). Any Bid contract extension is subject to the continuation of need and usage by the City and the appropriation of funds.

26. TERMINATION OF CONTRACT RESULTING FROM THIS ITB:

The City of Raleigh reserves the right to cancel the whole or any part of a resulting Contract due to failure by the Supplier to carry out any obligation, term or condition as described in the below procedure. Prior to any termination for cause, the City will provide written notice to the Supplier, opportunity to respond and opportunity to cure. Some examples of material breach include, but are not limited to:

1. The Supplier provides product that does not meet reasonable quality standards and is not remedied in a timely manner.
2. The Supplier fails to ship the products or provide the delivery within a reasonable amount of time;
3. The City has reason to believe the Supplier will not or cannot perform to the requirements or expectations of the Contract and issues a request for assurance and Supplier fails to respond.
4. The Supplier fails to observe any of the material terms and conditions of the Contract.
5. The Supplier fails to follow the established procedure for ordering and invoicing as established by the City and the Supplier in the Contract.
6. The Supplier fails to report quarterly sales;
7. Upon receipt of the written notice of concern, the Supplier shall have ten (10) business days to provide a satisfactory response to the City. Failure on the part of the Supplier to reasonably address all issues of concern may result in Contract cancellation pursuant to this Section. If the issue is not resolved within thirty (30) days, contract will be terminated.
8. Any termination shall have no effect on purchases that are in progress at the time the cancellation is received by the City.

The City reserves the right to cancel the Contract immediately for convenience, without penalty or recourse, in the event the Supplier is not responsive concerning the remedy, the performance, or the violation issue within the time frame, completely or in part.

9. The City reserves the right to cancel or suspend the use of any Contract resulting from this ITB if the Supplier files for bankruptcy protection or is acquired by an independent third party. Awarded Supplier will be responsible for disclosing to the City any litigation, bankruptcy or suspensions/disbarments that occur during the contract period. Failure to disclose may result in an immediate termination of the contract.
10. The City may execute Contract termination without cause with a required 60-day written notice of termination. Termination of Contract shall not relieve either party of financial, product or service obligations incurred or accrued prior to termination.
11. Events of Automatic termination to include, but not limited to:
 - a. Supplier's failure to remedy a material breach of a Contract resulting from this ITB within thirty (30) days of receipt of notice from the City specifying in reasonable detail the nature of such breach; and/or,
 - b. Receipt of written information from any authorized agency finding activities of the Supplier engaged in pursuant to a Contract resulting from this ITB to be in violation of the law.

27. **CONTRACT EXTENSIONS:**

The City reserves the right to extend all bid contracts for up to three (3) additional one (1) year periods from the date of the award of the original bid, if agreed upon in writing by the contracted Supplier. The contract extension(s) may be for additional quantities or for an additional time period as agreed.

28. **TRADE SECRETS:**

This Bid document and all Bidders' responses and proposals received are considered public information, except for trade secrets specifically identified in writing by the Bidder, which will be handled according to State Statute or other laws. Any section of the bidder's response package that is deemed to be a trade secret by the bidder shall be submitted in an envelope clearly marked "TRADE SECRET INFORMATION- DO NOT DISCLOSE." The City shall make a good faith effort to protect such confidential information.

29. **BID TABULATIONS:**

Bidders wishing to obtain a bid tabulation prior to the award of the bid may view and download tabulations from the eVP. Follow the steps provided at the Viewing and Responding to Solicitations in eVP / [Viewing Bid Tabulations and Awards in eVP](#).

30. **TERMS AND CONDITIONS:**

Acceptance of the City's Purchase Order includes acceptance of all applicable Terms and Conditions. The City's Purchase Order Terms & Conditions are provided below for your information.

CITY OF RALEIGH
STANDARD REQUIREMENTS

1. GENERAL:

The following specifications are intended to describe the minimum requirements for providing the City of Raleigh -Transportation Department with **SIGNS, BLANKS & POSTS** of the latest design and styles. Specific details listed below should be considered to be minimum requirements unless otherwise described. **Where no specifications are listed, the item is to be described as bid.** Applicable manufacturer's literature is to be included with the bid.

All items provided as described within these specifications and requirements must be new, unused, and of the manufacturer's latest design and model unless otherwise specified. All standard equipment for the product must be provided. All necessary parts not mentioned, but needed for the full operation of the product(s) specified must be supplied. Optional items and accessories may be priced separately if not specified.

Bidders must submit all manufacturer's literature, specifications, warranty information, etc. with their bid proposal.

The awarded bidder will be required to deliver the Signs, Blanks & Posts within the time frame needed and/or agreed upon by the awarded bidder and the City of Raleigh – Transportation Department. The awarded bidder must deliver the product ready for operational use. Specific details listed below are to be considered minimum requirements unless otherwise stated. Where no specifications are stated, the item is to be described as bid. All vendors and contractors, the bids submitted, and the items and equipment proposed, must meet the minimum requirements and specifications herein.

All items and product, and the prices proposed in response to this Bid are to include all transport, freight and fuel surcharges, and be delivered FOB Raleigh, North Carolina to the location provided on the City Purchase Order.

2. EXCEPTIONS TAKEN TO SPECIFICATIONS:

Bidders must note clearly any and all exceptions taken to the specifications, either written on the specification page(s), or attached on a separate page and returned with their bid proposal. The specifications were not written to intentionally eliminate any one bidder, but to be used as a guide for the size and quality of the equipment requested. In some instances, a particular manufacturer and model may be specified with or without an approved equal. It is noted that different manufacturers will have differences in engineering and design of equipment. Bidders must note these differences as an "Exception" and include detail information explaining how the exception is "equal to" or "exceeds" the intent of the specification. All exceptions and items submitted as an equal will be evaluated. The City reserves the right to reject any and all bids and to waive any irregularities or technicalities in bids received whenever such rejection or waiver is in the best interest of the City of Raleigh.

3. CUSTOMER SUPPORT:

1. Supplier will designate one individual who will represent the awarded supplier. This contact person will correspond to technical assistance, questions or problems that may arise.
2. Qualified telephone support shall be available during the CITY's standard business hours (8:30 a.m. - 5:15 p.m. EST, Monday through Friday). Customer support shall include live telephone access, internet site access and email access.

Supplier's contact person name: _____

Supplier's support telephone number is: () _____

Supplier's internet site (web) address is: _____

Supplier's support email address is: _____

3. Responses to requests for assistance shall be within one (1) business day from request date.

TERMINATION OF CONTRACT RESULTING FROM THIS ITB:

The City of Raleigh reserves the right to cancel the whole or any part of a resulting Contract due to failure by the Supplier to carry out any obligation, term or condition as described in the below procedure. Prior to any termination for cause, the City will provide written notice to the Supplier, opportunity to respond and opportunity to cure. Some examples of material breach include, but are not limited to:

1. The Supplier provides product that does not meet reasonable quality standards and is not remedied in a timely manner.
2. The Supplier fails to ship the products or provide the delivery within a reasonable amount of time;
3. The City has reason to believe the Supplier will not or cannot perform to the requirements or expectations of the Contract and issues a request for assurance and Supplier fails to respond;
4. The Supplier fails to observe any of the material terms and conditions of the Contract;
5. The Supplier fails to follow the established procedure for ordering and invoicing as established by the City and the Supplier in the Contract.
6. The Supplier fails to report quarterly sales;
7. Upon receipt of the written notice of concern, the Supplier shall have ten (10) business days to provide a satisfactory response to the City. Failure on the part of the Supplier to reasonably address all issues of concern may result in Contract cancellation pursuant to this Section. If the issue is not resolved within thirty (30) days, contract will be terminated.
8. Any termination shall have no effect on purchases that are in progress at the time the cancellation is received by the City. The City reserves the right to cancel the Contract immediately for convenience, without penalty or recourse, in the event the Supplier is not responsive concerning the remedy, the performance, or the violation issue within the time frame, completely or in part.
9. The City reserves the right to cancel or suspend the use of any Contract resulting from this ITB if the Supplier files for bankruptcy protection or is acquired by an independent third party. Awarded Supplier will be responsible for disclosing to the City any litigation, bankruptcy or suspensions/disbarments that occur during the contract period. Failure to disclose may result in an immediate termination of the contract.
10. The City may execute Contract termination without cause with a required 60-day written notice of termination. Termination of Contract shall not relieve either party of financial, product or service obligations incurred or accrued prior to termination.
11. Events of Automatic termination to include, but not limited to:
 - a. Supplier's failure to remedy a material breach of a Contract resulting from this ITB within thirty (30) days of receipt of notice from the City specifying in reasonable detail the nature of such breach; and/or,
 - b. Receipt of written information from any authorized agency finding activities of the Supplier engaged in pursuant to a Contract resulting from this ITB to be in violation of the law.

The Remainder of this Page Intentionally Left Blank

CITY OF RALEIGH PURCHASE ORDER TERMS & CONDITIONS

Supplier quotes or proposals are referenced for scope only.

City of Raleigh Purchase Order Terms & Conditions exclusively governs this purchase.

1. All invoices are to be sent by email to: accountspayable@raleighnc.gov or mail or deliver all invoices to the **City of Raleigh, Accounts Payable, PO Box 590, Raleigh NC 27602-0590.**
2. **Important: All invoices must include a unique invoice number and this Purchase Order number.** Invoices submitted without the unique invoice number or without the correct purchase order number will result in delayed payment.
3. Invoices for partial deliveries must be indicated as such.
4. The Supplier must provide separate invoices for each Purchase Order number.
5. **The City of Raleigh is not exempt from North Carolina State Sales Tax, Wake County Sales Tax, and Wake County Prepared Meals and Hotel Room Taxes.** These taxes must be correctly invoiced to the City for payment. Taxes shown on the purchase order are approximate.
6. The City of Raleigh is exempt from Federal Excise Tax. If any form of such tax is billed on the invoice, it must be shown as a separate item. Tax Exemption Certificates will be furnished upon request.
7. Payment term discounts will be deducted as provided for on the front of this Purchase Order or in accordance with the terms of your official quotation or bid. **Net purchases will be paid 30 days from the date of your invoice, or upon acceptance of goods whichever is later.**
8. **Important: All packages must bear the correct Purchase Order number on the outside of each package or shipping container.**
9. The City of Raleigh will not be responsible for any goods delivered without a Purchase Order having been issued.
10. The conditions of this order cannot be modified except by written amendment in the form of a "Corrected Purchase Order" which has been approved by the City of Raleigh's Purchasing Manager.
11. Any rejected materials will be returned to the Supplier at the Supplier's risk and expense.
12. In the event of a Supplier's failure to deliver or perform as specified, the City reserves the right to cancel the order or any part thereof, without prejudice to its other rights. The Supplier agrees that the City may return part or all of any shipment and may charge the Supplier with all reasonable losses or expenses sustained as a result of such failure to deliver or perform.
13. In case of default of the contractor, the City may procure the articles or services from other sources and charge the Supplier damages for any excess costs or other damages caused by the default.
14. It is agreed that the goods, materials, equipment or services provided shall comply with all Federal, State or local laws, and that the Supplier shall defend actions or claims brought, and save harmless the City, and/or its officials or employees, from loss, cost or damage by reason of actual or alleged failure to comply with such laws.
15. All prices must be F.O.B. Destination and delivered to the destination indicated on the front of the purchase order. Where specific purchase is quoted or negotiated F.O.B. Shipping Point, the Supplier is to prepay the shipping charges and add them to the invoice.
16. The risk of loss and damage to the goods which are the subject of this order shall be the Supplier's until the goods are delivered to the destination set out in the order and accepted by the purchaser or its representative.
17. The Supplier acknowledges that it is the policy of the City of Raleigh to avoid commercial promotion of products used by the City or the Suppliers of such products. The Supplier accordingly agrees not to solicit, use, or disseminate commercial advertisement founded upon the City's purchase and/or use of the goods which are the subject of this order, and specifically agrees not to seek or use for advertising purposes the endorsement of goods or products by City officers or employees.
18. The City may, at any time, insist upon strict compliance with these terms and conditions, notwithstanding any previous customer, practice or course of dealing to the contrary. **Acceptance of the order includes acceptance of all terms, conditions, prices, delivery instructions and specifications as shown on this order or attached to and made a part of this order.**
19. All matters relating to this Purchase Order shall be governed by the laws of the State of North Carolina, without regard to its choice of law provisions, and venue for any action relating to this Contract shall be Wake County Civil Superior Court or the United States District Court for the Eastern District of North Carolina, Western Division.
20. Notwithstanding any other provisions of this Purchase Order, this Purchase Order and all materials submitted to the City by the Supplier are subject to the public records laws of the State of North Carolina and it is the responsibility of the

Supplier to properly designate materials that may be protected from disclosure as trade secrets under North Carolina law as such and in the form required by law prior to the submission of such materials to the City. Supplier understands and agrees that the City may take any and all actions necessary to comply with federal, state, and local laws and/or judicial orders and such actions will not constitute a breach of the terms of this Purchase Order. To the extent that any other provisions of this Purchase Order conflict with this paragraph, the provisions of this section shall control.

21. **Non-discrimination** – To the extent permitted by North Carolina law, the Parties for themselves, their agents, officials, directors, officers, members, representatives, employees, and contractors agree not to discriminate in any manner or in any form based on actual or perceived age, mental or physical disability, sex, religion, creed, race, color, sexual orientation, gender identity or expression, familial or marital status, economic status, veteran status or national origin in connection with this Contract or its performance. The Parties agree to conform with the provisions and intent of Raleigh City Code §4-1004 in all matters related to this Contract. This provision is incorporated into the Contract for the benefit of the City of Raleigh and its residents and may be enforced by an action for specific performance, injunctive relief, or any other remedy available at law or equity. This section shall be binding on the successors and assigns of all parties with reference to the subject matter of the Purchase Order.

22. **Insurance** – If performing services under this Purchase Order the Supplier agrees to maintain, on a primary basis and at its sole expense, at all times during the life of this Purchase Order the following coverages and limits. The requirements contained herein, as well as City’s review or acceptance of insurance maintained by Supplier is not intended to and shall not in any manner limit or qualify the liabilities or obligations assumed by Supplier under this Purchase Order:

- a. **Workers’ Compensation Insurance** - Supplier agrees to maintain Worker’s Compensation Insurance in accordance with North Carolina General Statute Chapter 97 and with limits of no less than \$1,000,000 each accident, each employee and policy limit.
- b. **Commercial General Liability** - Combined single limit of no less than \$1,000,000 each occurrence and \$2,000,000 aggregate. Coverage shall not contain any endorsement(s) excluding nor limiting Product/Completed Operations, Contractual Liability or Cross Liability.
- c. **Commercial Automobile Liability** - Limits of no less than \$1,000,000 Combined Single Limit. Coverage shall include liability for Owned, Non-Owned and Hired automobiles. In the event Supplier does not own automobiles, Supplier agrees to maintain coverage for Hired and Non-Owned Auto Liability, which may be satisfied by way of endorsement to the Commercial General Liability policy or separate Auto Liability policy. Automobile coverage is only necessary if vehicles are used in the provision of services under this Purchase Order and/or are brought on a COR site.
- d. **Additional Insured** - Supplier agrees to endorse the City as an Additional Insured on the Commercial General Liability. The Additional Insured shall read ‘City of Raleigh as its interest may appear’.
- e. **Umbrella or Excess Liability** - Supplier may satisfy the minimum liability limits required above under an Umbrella or Excess Liability policy. There is no minimum Per Occurrence limit of liability under the Umbrella or Excess Liability, however, the Annual Aggregate limits shall not be less than the highest ‘Each Occurrence’ limit for required policies. Supplier agrees to endorse City of Raleigh as an ‘Additional Insured’ on the Umbrella or Excess Liability, unless the Certificate of Insurance states the Umbrella or Excess Liability provides coverage on a ‘Follow-Form’ basis.
- f. **Professional Liability** - Limits of no less than \$1,000,000 each claim. This coverage is only necessary for professional services such as engineering, architecture or when otherwise required by the City. The City reserves the right to require a Certificate of Insurance meeting the minimum coverage and requirements of this section. Certificates of Insurance shall provide a minimum thirty (30) day endeavor to notify, when available, by Supplier’s insurer. If Supplier receives a non-renewal or cancellation notice from an insurance carrier affording coverage required herein, or receives notice that coverage no longer complies with the insurance requirements herein, Supplier agrees to notify the City within five (5) business days with a copy of the non-renewal or cancellation notice, or written specifics as to which coverage is no longer in compliance.

The certificate holder address should read:

City of Raleigh
 Post Office Box 590
 Raleigh, NC 27602

All insurance companies must be authorized to do business in North Carolina and be acceptable to the City of Raleigh’s Risk Manager.

23. **Indemnity** – To the fullest extent permitted by law, except to the extent caused by the sole negligence or willful misconduct of the City, the Supplier shall indemnify and hold and save the City, its officers, agents and employees, harmless from liability of any kind, including all claims, costs (including defense) and losses accruing or resulting to

any other person, firm, or corporation furnishing or supplying work, services, materials, or supplies in connection with the performance of this Purchase Order, and from any and all claims, costs (including defense) and losses accruing or resulting to any person, firm, or corporation that may be injured or damaged by the Supplier in the performance of this Purchase Order. This representation and warranty shall survive the termination or expiration of this Purchase Order. The Supplier shall indemnify and hold and save the City, its officers, agents and employees, harmless from liability of any kind, including claims, costs (including defense) and expenses, on account of any copyrighted material, patented or unpatented invention, articles, device or appliance manufactured or used in the performance of this Purchase Order.

24. **Intellectual Property** - All intellectual property, including, but not limited to, patentable inventions, patentable plans, copyrightable works, mask works, trademarks, service marks and trade secrets invented, developed, created or discovered in performance of services under this Purchase Order shall be the property of the City. Copyright in and to any copyrightable work, including, but not limited to, copy, art, negatives, photographs, designs, text, software, or documentation created as part of the Supplier's performance of services under this Purchase Order shall vest in the City. Works of authorship and contributions to works of authorship created by the Supplier's performance of services under this Purchase Order are hereby agreed to be 'works made for hire' within the meaning of 17 U.S.C. 201.
25. **Force Majeure** - Neither party shall be deemed to be in default of its obligations hereunder if and so long as it is prevented from performing such obligations by an act of war, hostile foreign actions, nuclear explosion, earthquake, hurricane, tornado, or other catastrophic natural event or act of God. Except at otherwise provided in any environmental laws, rules, regulations or ordinances applicable to the parties and the services performed under this Purchase Order, neither party shall be deemed to be in default of its obligations hereunder if and so long as it is prevented from performing such obligations by an act of war, hostile foreign actions, nuclear explosion, earthquake, hurricane, tornado, or other catastrophic natural event or act of God. Either party to the Purchase Order must take reasonable measures and implement reasonable protections when a weather event otherwise defined as a force majeure event is forecast to be eligible to be excused from the performance otherwise required under this Purchase Order by this provision.
26. **Cancellation** - The City may terminate this Purchase Order at any time by providing written notice to the Supplier. Supplier shall cease performance immediately upon receipt of such notice. In the event of early termination, Supplier shall be entitled to receive just and equitable compensation for costs incurred prior to receipt of notice of termination and for the satisfactory work completed as of the date of termination and delivered to the City. Notwithstanding the foregoing, in no event will the total amount due to Supplier under this section exceed the total amount due Supplier under this Purchase Order.
27. **Miscellaneous** - The Supplier shall be responsible for the proper custody and care of any property furnished or purchased by the City for use in connection with the performance of this Purchase Order and will reimburse the City for the replacement value of its loss or damage. The Supplier shall be considered an Independent Contractor and as such shall be wholly responsible for the work to be performed and for the supervision of its employees. Nothing herein is intended or will be construed to establish any agency, partnership, or joint venture. Supplier represents that it has, or will secure at its own expense, all personnel required in performing the services under this Purchase Order. Such employees shall not be employees of or have any individual contractual relationship with the City.
28. **E-Verify** - I understand that E-Verify is the federal E-Verify program operated by the United States Department of Homeland Security and other federal agencies, or any successor or equivalent program used to verify the work authorization of newly hired employees pursuant to federal law in accordance with NC G.S. §64-25 et seq. I am aware of and in compliance with the requirements of E-Verify and Article 2 of Chapter 64 of the North Carolina General Statutes. To the best of my knowledge, any subcontractors employed by me as a part of this contract are in compliance with the requirements of E-Verify and Article 2 of Chapter 64 of the North Carolina General Statutes.
29. **Iran Divestment Act Certification** – Contractor certifies that, as of the date listed below, it is not on the Final Divestment List as created by the State Treasurer pursuant to NC G.S. §147-86.55, *et seq.* In compliance with the requirements of the Iran Divestment Act and NC G.S. §147-86.59, Contractor shall not utilize in the performance of the contract any subcontractor that is identified on the Final Divestment List.
30. **Companies Boycotting Israel Divestment Act Certification** - Contractor certifies that it has not been designated by the North Carolina State Treasurer as a company engaged in the boycott of Israel pursuant to NC G.S. §147-86.81.

MINIMUM SPECIFICATIONS:

The Signs, Blanks and Post must meet the following minimum specifications:

MEETS/EXCEEDS SPECIFICATIONS	YES	NO
<p>1. MEETS/EXCEEDS SPECIFICATIONS</p> <p>The quantities given are estimated. Orders will be placed with the successful bidder on an as needed basis. Unit pricing shall be fixed for the period of 12 consecutive months.</p>	<input type="checkbox"/>	<input type="checkbox"/>
<p>2. MEETS/EXCEEDS SPECIFICATIONS</p> <p>It is the intent of the City of Raleigh that this bid be awarded by group or by total amount whichever is in the best interest of the City. The contract supplier must bid a minimum of 95% of one group or the City reserves the right to reject the bid.</p>	<input type="checkbox"/>	<input type="checkbox"/>
<p>3. MEETS/EXCEEDS SPECIFICATION</p> <p>No additional fees for special orders, delivery, freight or returns are permissible.</p>	<input type="checkbox"/>	<input type="checkbox"/>
<p>4. MEETS/EXCEEDS SPECIFICATION</p> <p>Deliver orders within 3 to 4 weeks. No additional fees are permissible.</p>	<input type="checkbox"/>	<input type="checkbox"/>

GROUP 1 – METAL POST – 14 GAUGE METAL PRICE SHEET				
ITEM No.	ITEM DESCRIPTION	ESTIMATED ANNUAL QUANTITY	UNIT PRICE/UOM (Each)	EXTENDED PRICE
1	12' U Channel Post	1000 EA	\$ _____ /EA	\$ _____
2	11' U Channel Post	1000 EA	\$ _____ /EA	\$ _____
3	10' U Channel Post	1000 EA	\$ _____ /EA	\$ _____
4	12' Square Street Marker Post	1000 EA	\$ _____ /EA	\$ _____
5	10' Black Square Street Marker Post	50 EA	\$ _____ /EA	\$ _____
6	2 X 2 Post Rain Caps	600 EA	\$ _____ /EA	\$ _____
7	12' Punch Post	1000 EA	\$ _____ /EA	\$ _____
8	6' U channel post	300 EA	\$ _____ /EA	\$ _____
9	8" U Channel post	300 EA	\$ _____ /EA	\$ _____
	POST MUST BE DELIVERED ON FLATBED TRUCK Delivery in ____ days after receipt of order Meets or exceeds specifications: <input type="checkbox"/> YES <input type="checkbox"/> NO (explain)			GROUP 1 TOTAL: \$ _____ FOB Destination

GROUP 2 – SIGN BLANKS – .080 THICKNESS PRICE SHEET				
ITEM No.	ITEM DESCRIPTION	ESTIMATED ANNUAL QUANTITY	UNIT PRICE/UOM (Each)	EXTENDED PRICE
1	Aluminum blank sign 9 X 30	1000 EA	\$ _____/EA	\$ _____
2	Aluminum blank sign 9 X 36	2000 EA	\$ _____/EA	\$ _____
3	Aluminum blank sign 9 X 42	2000 EA	\$ _____/EA	\$ _____
4	Aluminum blank sign 9 X 48	1000 EA	\$ _____/EA	\$ _____
5	Aluminum blank sign 9 X 54	600 EA	\$ _____/EA	\$ _____
6	Aluminum blank sign 9 X 60	500 EA	\$ _____/EA	\$ _____
7	Aluminum blank sign 12 X 18	1500 EA	\$ _____/EA	\$ _____
8	Aluminum blank sign 12 X 36	500 EA	\$ _____/EA	\$ _____
9	Aluminum blank sign 18 X 18	500 EA	\$ _____/EA	\$ _____
10	Aluminum blank sign 18 X 24	500 EA	\$ _____/EA	\$ _____
11	Aluminum blank sign 24 X 30	1500 EA	\$ _____/EA	\$ _____
12	Stop Sign blanks 30 X 30	1000 EA	\$ _____/EA	\$ _____
13	6" X 9" Aluminum blank Sign	300 EA	\$ _____/EA	\$ _____

**GROUP 2 – SIGN BLANKS – .080 THICKNESS
PRICE SHEET**

ITEM No.	ITEM DESCRIPTION	ESTIMATED ANNUAL QUANTITY	UNIT PRICE/UOM (Each)	EXTENDED PRICE
14	6" X 12" Aluminum blank sign	500 EA	\$ _____/EA	\$ _____
15	8" X 24" Aluminum blank sign	300 EA	\$ _____/EA	\$ _____
16	9" X 12" Aluminum blank sign	300 EA	\$ _____/EA	\$ _____
17	12" X 24" Aluminum blank sign	300 EA	\$ _____/EA	\$ _____
18	24" X 24" Aluminum blank sign	300 EA	\$ _____/EA	\$ _____
19	30" X 30" Aluminum blank sign	300 EA	\$ _____/EA	\$ _____
20	30" X 60" Alpolic blank sign	300 EA	\$ _____/EA	\$ _____
21	30" X 42" Alpolic blank sign	300 EA	\$ _____/EA	\$ _____
22	36" X 36" Alpolic blank sign	300 EA	\$ _____/EA	\$ _____
	Delivery in ____ days after receipt of order. Meets or exceeds specifications: <input type="checkbox"/> YES <input type="checkbox"/> NO (explain)			GROUP 2 TOTAL: \$ _____ FOB Destination

GROUP 3 – SIGN FACE PRICE SHEET				
ITEM No.	ITEM DESCRIPTION	ESTIMATED ANNUAL QUANTITY	UNIT PRICE/UOM (Each)	EXTENDED PRICE
1	Yield Sign Faces 36 X 36 HIP	500 EA	\$ _____/EA	\$ _____
	Delivery in _____ days after receipt of order. Meets or exceeds specifications: <input type="checkbox"/> YES <input type="checkbox"/> NO (explain)			GROUP 3 TOTAL: \$ _____ FOB Destination

**GROUP 4 – SHEETING
PRICE SHEET**

ITEM No.	ITEM DESCRIPTION	ESTIMATED ANNUAL QUANTITY	UNIT PRICE/UOM (Each)	EXTENDED PRICE
1	1172-C Red 36 X 50	20 EA	\$ _____/EA	\$ _____
2	3M 1177-C Green 30 X 50	20 EA	\$ _____/EA	\$ _____
3	3M 1177-C Green 36 X 50	20 EA	\$ _____/EA	\$ _____
4	3M 3930 White 24 X 50	20 EA	\$ _____/EA	\$ _____
5	3M 3930 White 30 X 50	20 EA	\$ _____/EA	\$ _____
6	3M 3930 White 36 X 50	20 EA	\$ _____/EA	\$ _____
7	3M 7725-12 Black 24 X 50	20 EA	\$ _____/EA	\$ _____
8	3M 7725-12 Black 30 X 50	20 EA	\$ _____/EA	\$ _____
9	3M 7725-12 Black 36 X 50	20 EA	\$ _____/EA	\$ _____
10	3931 Yellow 30 X50	20 Rolls	\$ _____/EA	\$ _____
11	3M SCPS-2 Pre-Space Tape 24 X 100	5 EA	\$ _____/EA	\$ _____
12	3M SCPS-2 Pre-Space Tape 30 X 100	10 EA	\$ _____/EA	\$ _____
13	3M SCPS-2 Pre-Space Tape 36 X 100	5 EA	\$ _____/EA	\$ _____
14	3M 1172 – C Red 24 X 50	20 EA	\$ _____/EA	\$ _____

**GROUP 4 – SHEETING
PRICE SHEET**

ITEM No.	ITEM DESCRIPTION	ESTIMATED ANNUAL QUANTITY	UNIT PRICE/UOM (Each)	EXTENDED PRICE
15	3M 1175 – C Blue 24 X 50	20 EA	\$ _____ /EA	\$ _____
16	3M 1175 – C Blue 36 X 50	20 EA	\$ _____ /EA	\$ _____
17	3M 1179 – C Brown 24 X 50	20 EA	\$ _____ /EA	\$ _____
18	3M 1179 – C Brown 36 X 50	20 EA	\$ _____ /EA	\$ _____
19	3M 1170 – C Clear 8 X 50	20 EA	\$ _____ /EA	\$ _____
20	3M 1170 – C Clear 24 X 50	20 EA	\$ _____ /EA	\$ _____
21	3M 1170 – C Clear 30 X 50	20 EA	\$ _____ /EA	\$ _____
22	3M 1170 – C Clear 36 X 50	20 EA	\$ _____ /EA	\$ _____
23	3M 3931 HIP Yellow 36 X 50	20 EA	\$ _____ /EA	\$ _____
24	3M 3983 Yellow-Green 30 X 50	10 EA	\$ _____ /EA	\$ _____
25	3M 3883 Yellow-Green 36 X 50	10 EA	\$ _____ /EA	\$ _____
26	3M 3924 DGF Orange 36 X 50	10 EA	\$ _____ /EA	\$ _____
	Delivery in _____ days after receipt of order. Meets or exceeds specifications: <input type="checkbox"/> YES <input type="checkbox"/> NO (explain)			GROUP 4 TOTAL: \$ _____ FOB Destination

GROUP 5 – BOLTS PRICE SHEET				
ITEM No.	ITEM DESCRIPTION	ESTIMATED ANNUAL QUANTITY	UNIT PRICE/UOM (Each)	EXTENDED PRICE
1	Aluminum Bolts 5/16 x 2	15,000 EA	\$ _____ /EA	\$ _____
2	Aluminum Bolts 5/16 X 2 ½	15,000 EA	\$ _____ /EA	\$ _____
3	Aluminum Break off Nut 5/16	15,000 EA	\$ _____ /EA	\$ _____
	Delivery in _____ days after receipt of order. Meets or exceeds specifications: <input type="checkbox"/> YES <input type="checkbox"/> NO (explain)			GROUP 5 TOTAL: \$ _____ FOB Destination

POSITIVELY NO BIDS CONSIDERED UNLESS SUBMITTED ON THIS FORM

COMPANY: _____ DATE: _____

AUTHORIZED SIGNATURE: _____ TITLE: _____

Street Sign and Post Diagrams

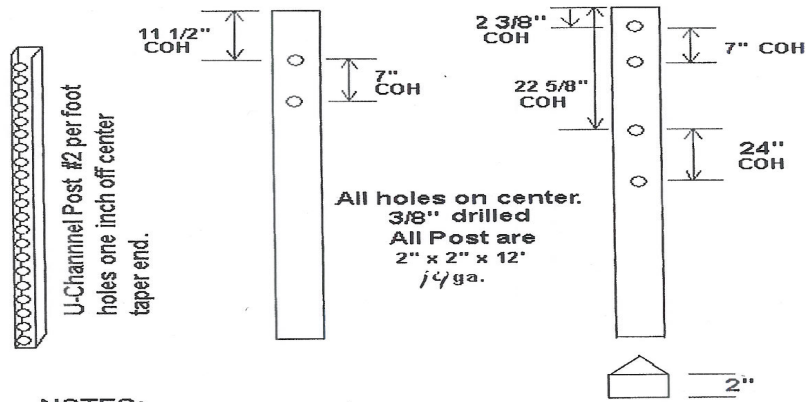
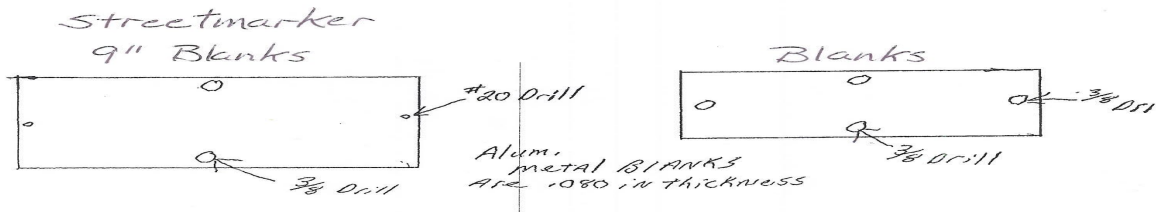

NOTES:

2" Rain Cap
Fits over the square post
only

• Here are the new COR 2" sq. 14 ga. post hole patterns for our new street blade installations. We are now using 9" blades for both our Major and Minor Street identification. All post ordered from this day forward will have this pattern. •

SPECIFICATIONS

DESIGN
Posts are to be of a modified channel design with two ribs along the back of the post.

MATERIALS & FINISH
Posts shall be fabricated from high-strength billet steel conforming to FHWA Technical Advisory T5040-22 dated September 27, 1983, titled "Steel Flanged Channel Posts for Small Highway Sign Supports." SP-80 is the mill grade designation that corresponds to the advisory. The minimum yield is 80,000 PSI, and the minimum tensile is 100,000 PSI.

The cast heat analysis of the steel shall conform to the following requirements:

Element:	Composition (%):
Carbon	0.57 - 0.82
Manganese	0.70 - 1.10
Phosphorous (Max)	.04
Sulphur (Max)	.05
Silicon	0.10 - 0.25

Weight of the post shall be as specified by the user, plus or minus 5% before punching. The posts shall be punched with continuous 3/8" diameter holes on 1" centers for the entire length of the post. The first hole shall be 1" from the top.

The posts shall be machine straightened to have a smooth, uniform finish, free from defects affecting their strength, durability or appearance. All holes and rough edges shall be free from burrs. The permissible tolerance for straightness shall be within 1/4" in 5'.

The Posts shall be coated with a baked on enamel, powder coating, or hot-dipped galvanized to ASTM -A123.

SECTION PROPERTIES

WEIGHT lb _w /ft.	DIMENSIONS				AREA IN ²	X-X AXIS**		Y-Y AXIS	
	A*	B*	C*	D*		(IN ²)	S (IN ³)	(IN ²)	S (IN ³)
2.00	1.462	3.062	1.278	.689	.556	.195	.422	.278	
2.50	1.516	3.062	1.278	.689	.701	.208	.449	.359	
2.75	1.536	3.062	1.278	.689	.756	.228	.470	.391	
3.00	1.881	3.500	1.338	.834	.840	.376	.340	.837	
4.00	1.968	3.500	1.338	.834	1.112	.540	.467	1.147	

* + or - .5%

** Governing section

INTENDED USE
Small Sign Supports

SUPPLIER: WARRON STEEL CO.

RIB-BAK® U-CHANNEL SIGN SUPPORTS

40502
1 OF 2
REV. 08/97

INSTALLATION OPTIONS

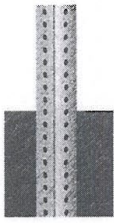

Direct Installation

POZ-LOC Performance Posts can be driven directly into the ground utilizing power equipment or working manually with a sledgehammer and drive cap.

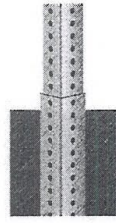

Breakaway Anchor Installation

A POZ-LOC Performance Post anchor can be driven into the ground first, allowing crews to work at ground level for quicker, cost-effective installations or replacement of damaged signposts.

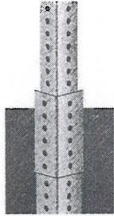

Super Strength Installation

Our two-piece breakaway anchor/sleeve combination is an ideal solution for applications requiring frequent signpost replacement in high impact locations.

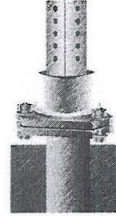

Slipbase Installation

When sign size or highway location dictate installation of a slipbase sign support system, the POZ-LOC S-Q Post Slipbase System is the logical choice. This system, designed for mounting either solid or perforated square signposts, is a maintenance-friendly and cost-effective sign support solution.

SECTIONAL PROPERTIES

Size	USS Gauge	Weight perforated (lbs/foot)	Weight non-perforated (lbs/foot)	Area (inches ²)	Moment of Inertia (inches ⁴)	Section Modulus (inches ³)	Radius of Gyration (inches)
1.50" x 1.50" 38.10 x 38.10mm	14 2.11mm	1.42 2.13kg/m	1.60 2.38kg/m	0.316 203.59mm ²	0.112 46646mm ³	0.149 2449mm ³	0.596 15.14mm
1.75" x 1.75" 44.45 x 44.45mm	14 2.11mm	1.71 2.56kg/m	1.89 2.81kg/m	0.399 257.14mm ²	0.195 81341mm ³	0.223 3660mm ³	0.700 17.79mm
2.00" x 2.00" 50.80 x 50.80mm	14 2.11mm	2.00 2.99kg/m	2.17 3.24kg/m	0.482 310.69mm ²	0.311 129495mm ³	0.311 5098mm ³	0.804 20.42mm
2.25" x 2.25" 57.15 x 57.15mm	14 2.11mm	2.29 3.41kg/m	2.46 3.67kg/m	0.565 364.24mm ²	0.464 193268mm ³	0.413 6764mm ³	0.907 23.04mm
1.50" x 1.50" 38.10 x 38.10mm	12 2.60mm	1.72 2.56kg/m	1.93 2.88kg/m	0.377 243.49mm ²	0.130 54057mm ³	0.173 2838mm ³	0.587 14.90mm
1.75" x 1.75" 44.45 x 44.45mm	12 2.60mm	2.07 3.09kg/m	2.29 3.41kg/m	0.480 309.62mm ²	0.229 95180mm ³	0.261 4283mm ³	0.690 17.53mm
2.00" x 2.00" 50.80 x 50.80mm	12 2.60mm	2.43 3.62kg/m	2.64 3.94kg/m	0.582 375.74mm ²	0.367 152585mm ³	0.367 6007mm ³	0.793 20.15mm
2.25" x 2.25" 57.15 x 57.15mm	12 2.60mm	2.78 4.15kg/m	3.00 4.47kg/m	0.685 441.87mm ²	0.550 228940mm ³	0.489 8012mm ³	0.896 22.76mm
2.50" x 2.50" 63.50 x 63.50mm	12 2.60mm	3.14 4.68kg/m	3.42 5.10kg/m	0.763 491.99mm ²	0.775 322579mm ⁴	0.620 10160mm ⁴	1.008 25.60mm
2.50" x 2.50" 63.50 x 63.50mm	10 3.43mm	4.12 6.15kg/m	4.40 6.57kg/m	1.033 666.46mm ²	0.987 410915mm ³	0.790 12942mm ³	0.978 24.83mm

POZ-LOC Performance Posts.
A tough-to-beat addition to an already road-tested line.

The latest in our line of small sign support systems, POZ-LOC Performance Posts are made to complement Northwest Pipe's round and square tubing products and our breakaway sign support systems. Already in use by DOT organizations nationwide, these systems have been independently tested by the Texas Transportation Institute and shown to meet or exceed the requirements of NCHRP #350.

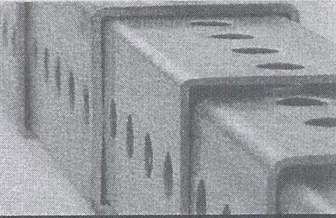

PERFORMANCE POST FEATURES

- 7/16" diameter holes punched on 1" centers, all four sides
- G90 galvanized with acrylic polymer clear coat
- Powder-coated colors
- Custom hole patterns available
- Available in 1 1/2" to 2 1/2" in 12 and 14 gauge, 2 1/2" in 10 gauge for larger sign installations.

REFERENCES

Provide at least three (3) references, other than the City of Raleigh, for which your company has provided goods and services of substantially the same features and quantity to those solicited herein. References shall be checked during the evaluation period to determine that the goods provided are substantially similar to those bid herein and that the supplier’s performance has been satisfactory. Information obtained will be considered in evaluation of the bids. Bidders are cautioned to provide accurate information. Misleading information presented in the references may result in a rejection of the proposal.

1. **Agency or Company Name** _____

Business Address _____

Contact Person _____

Contact Telephone Number _____

Contact E-Mail Address _____

2. **Agency or Company Name** _____

Business Address _____

Contact Person _____

Contact Telephone Number _____

Contact E-Mail Address _____

3. **Agency or Company Name** _____

Business Address _____

Contact Person _____

Contact Telephone Number _____

Contact E-Mail Address _____