

ORANGE COUNTY ASSET MANAGEMENT - LITTLE RIVER PARK  
301 LITTLE RIVER PARK WAY, ROUGEMONT, NC 27572

# **CONTRACT PROPOSAL**



**ITB NUMBER: 367-OC5481**

**DESCRIPTION: PAVING, INCIDENTAL MILLING, REMOVING ASPHALT/TREE ROOT, POURING ADA CONCRETE PARKING SPACES, REMOVING AND REPLACING WOODEN WHEEL BUMP STOPS, INSTALLING TRUNCATED DOMES, INSTALLING 15" DRAINAGE PIPE, LAYING GRAVEL, INSTALLING SURFACE-MOUNTED SPEED BUMPS, AND PARKING LOT RE-STRIPING**

**BID OPENING: April 29<sup>th</sup>, 2026**

**NOTICE:**

**ALL BIDDERS SHALL COMPLY WITH ALL APPLICABLE LAWS REGULATING THE PRACTICE OF GENERAL CONTRACTING AS CONTAINED IN CHAPTER 87 OF THE GENERAL STATUTES OF NORTH CAROLINA WHICH REQUIRES THE BIDDER TO BE LICENSED BY THE N.C. LICENSING BOARD FOR CONTRACTORS WHEN BIDDING ON ANY NON-FEDERAL AID PROJECT WHERE THE BID IS \$50,000 OR MORE, EXCEPT FOR CERTAIN SPECIALTY WORK AS DETERMINED BY THE LICENSING BOARD OR SBE PROJECT. BIDDERS SHALL ALSO COMPLY WITH ALL OTHER APPLICABLE LAWS REGULATING THE PRACTICES OF ELECTRICAL, PLUMBING, HEATING AND AIR CONDITIONING AND REFRIGERATION CONTRACTING AS CONTAINED IN CHAPTER 87 OF THE GENERAL STATUTES OF NORTH CAROLINA.**

---

NAME OF BIDDER

N.C. CONTRACTOR'S LICENSE NUMBER

---

ADDRESS OF BIDDER

**RETURN BIDS TO: ORANGE COUNTY FINANCE AND ADMINISTRATIVE SERVICES DEPARTMENT  
131 WEST MARGARET LANE, SUITE 300, HILLSBOROUGH, NC 27278  
ATTN: JOVANA AMARO, FINANCE MANAGER – PURCHASING**

## INSTRUCTIONS TO BIDDERS

### **PLEASE READ ALL INSTRUCTIONS CAREFULLY BEFORE PREPARING AND SUBMITTING YOUR BID.**

All bids shall be prepared and submitted in accordance with the following requirements. Failure to comply with any requirement shall cause the bid to be considered irregular and shall be grounds for rejection of the bid.

1. The bid sheet with the proposal shall be used and shall not be altered in any manner. **DO NOT SEPARATE THE BID SHEET FROM THE PROPOSAL!**
2. All entries on the bid sheet, including signatures, shall be written in ink.
3. The Bidder shall submit a unit price for every item on the bid form. The unit prices for the various contract items shall be written in figures.
4. An amount bid shall be entered on the bid sheet for every item. The amount bid for each item shall be determined by multiplying each unit bid by the quantity for that item and shall be written in figures in the "Amount Bid" column of the sheet.
5. The total amount bid shall be written in figures in the proper place on the bid sheet. The total amount shall be determined by adding the amounts bid for each item.
6. Changes in any entry shall be made by marking through the entry in ink and making the correct entry adjacent thereto in ink. A representative of the Bidder shall initial the change in ink.
7. The bid shall be properly executed. All bids shall show the following information:
  - a. Name of individual, firm, corporation, partnership, or joint venture submitting bid.
  - b. Name and signature of individual or representative submitting bid and position or title.
  - c. Name, signature, and position or title of witness.
  - d. Federal Identification Number (or Social Security Number of Individual)
  - e. Contractor's License Number (if Applicable)
8. Bids submitted by corporations shall bear the seal of the corporation.
9. The bid shall not contain any unauthorized additions, deletions, or conditional bids.
10. The bidder shall not add any provision reserving the right to accept or reject an award, or to enter into a contract pursuant to an award.
11. **THE PROPOSAL WITH THE BID SHEET STILL ATTACHED MAY BE PLACED IN A SEALED ENVELOPE AND SHALL HAVE BEEN DELIVERED TO AND RECEIVED BY:**  
TIME: **3:00 PM**  
DATE: **April 29<sup>th</sup>, 2026**
12. If delivered by mail, the sealed envelope shall be placed in another sealed envelope and the outer envelope shall be addressed as follows:

ORANGE COUNTY FINANCE AND ADMINISTRATIVE SERVICES DEPARTMENT  
131 WEST MARGARET LANE, SUITE 300, HILLSBOROUGH, NC 27278  
ATTN: JOVANA AMARO, FINANCE MANAGER – PURCHASING

### AWARD OF CONTRACT

**The award of the contract, if it be awarded, will be made to the lowest responsible Bidder in accordance with Section 102 (*excluding 102-2 and 102-11*) of the NCDOT Standard Specifications for Roads and Structures 2024. The lowest responsible BIDDER will be notified that his bid has been accepted and that he has been awarded the contract. The Owner reserves the right to reject any or all bids.**

## **Orange County Bid Checklist:**

The following forms must be returned with your bid package:

- Contractor's Completed and Signed Bid Forms
- Bid Bond
- Minority Business Participation Forms:
  - Identification of HUB Certified/ Minority Business Participation
  - Affidavit A or Affidavit B
- Safety Questionnaire with supporting documentation
- Living Wage Contractor Policy
- E-Verify Affidavit
- Orange County Nondiscrimination Certification
- Supplemental Vendor Information: Historically Underutilized Businesses

## **Minority Business Participation:**

The following forms are required to be completed and included with your bid:

- Identification of HUB Certified/ Minority Business Participation
- Affidavit A: Listing of Good Faith Efforts

**or**

- Affidavit B: Intent to Perform Contract with Own Workforce (If you intend to complete this project with your own workforce)

**\*\*\* If the above documents are not provided, your bid will be deemed non-responsive\*\*\***

**Please note:** Affidavit C or Affidavit D will be required to be submitted by the apparent lowest responsive, responsible bidder.

- **Affidavit C:** Portion of the Work to be Performed by HUB Certified/Minority Businesses (if the portion of the work to be executed by minority businesses is equal to or greater than 10% of the bidder's total contract price)

- **Affidavit D:** Good Faith Efforts (if the 10% participation goal is not achieved, the bidder must provide supporting documentation of their good faith efforts)

## TABLE OF CONTENTS

<u>SECTION</u>	<u>PAGE #</u>
ADVERTISEMENT FOR BIDS	1
INFORMATION FOR BIDDERS	2 - 3
BID DOCUMENT	4 - 5
BID FORM	6 - 7
LIST OF SUBCONTRACTORS	8
BID BOND	9 - 15
PAYMENT BOND	16 - 24
PERFORMANCE BOND	25 - 27
CONSTRUCTION AGREEMENT	28 - 35
ORANGE COUNTY GENERAL CONDITIONS	G1 - G47
GENERAL PROVISIONS	36 - 37
PROJECT SPECIAL PROVISIONS	38 - 45
E-VERIFY AFFIDAVIT	46
LIVING WAGE POLICY	47
W-9 FORM	48
DISPUTE RESOLUTION & PROCEDURES	49 - 53
NON-DISCRIMINATION ORDINANCE & CERTIFICATION	54 - 59
MINORITY BUSINESS PARTICIPATION REQUIREMENTS	60 - 62
MBE AFFIDAVITS	63 - 67
HISTORICALLY UNDERUTILIZED BUSINESSES IDENTIFICATION	68 - 69
CONTRACTOR SAFETY RECORD	70 - 73
ORANGE COUNTY MINIMUM INSURANCE REQUIREMENTS	74 - 75
PLAN SHEETS	S-1 – S-8

## **ADVERTISEMENT FOR BIDS**

Sealed bids will be received until **3:00 PM EST on April 29<sup>th</sup>, 2026** for the paving, incidental milling, removing asphalt/tree root, pouring ADA concrete parking stalls, removing and replacing wooden wheel bump stops, installing truncated domes, installing 15” drainage pipe, laying gravel, installing surface-mounted speed bumps, and parking lot re-striping.

The required Bid Documents may be mailed or hand delivered to the address listed below before **April 29<sup>th</sup> at 3:00 PM**.

Orange County Finance and Administrative Services Department  
131 West Margaret Lane, Suite 300, Hillsborough, NC 27278  
ATTN: Jovana Amaro, Finance Manager – Purchasing

**A virtual Pre-Bid meeting will be held on April 22<sup>nd</sup> at 2:00 PM. The meeting will be a Microsoft Teams meeting hosted by Summit Design and Engineering Services.**

**Pre-Bid Meeting Link: [https://teams.microsoft.com/l/meetup-join/19%3ameeting\\_YjM1NTg2YjMtODZhZS00YzE4LWE2NTMtYzI4MTg5YWJjNDlk%40thread.v2/0?context=%7b%22Tid%22%3a%221205635f-9cac-4896-b9ee-60d306d67314%22%2c%22Oid%22%3a%22430e9299-0a79-4f16-8841-5a23b7278d7d%22%7d](https://teams.microsoft.com/l/meetup-join/19%3ameeting_YjM1NTg2YjMtODZhZS00YzE4LWE2NTMtYzI4MTg5YWJjNDlk%40thread.v2/0?context=%7b%22Tid%22%3a%221205635f-9cac-4896-b9ee-60d306d67314%22%2c%22Oid%22%3a%22430e9299-0a79-4f16-8841-5a23b7278d7d%22%7d)**

The scope of work includes: **Paving, Incidental Milling, Removing Asphalt/Tree Root, Pouring ADA Concrete Parking Spaces, Removing and Replacing Wooden Wheel Bump Stops, Installing Truncated Domes, Installing 15” Drainage Pipe, Laying Gravel, Installing Surface-Mounted Speed Bumps, and Parking Lot Re-Striping.**

Contractors offering proposals on this project must be licensed to do the specified type of contracting in the State of North Carolina.

**Bidders must make positive efforts to utilize minority businesses. The Owner has developed a goal of ten percent (10%) for participation of minority business enterprises in construction contracts awarded pursuant to NCGS 143-128(c). Bidder shall be required to submit identification of firms and Affidavits as required in the Bid Form.**

Complete plans, specifications and contract documents will be open for inspection at Summit Engineering and Design Services, 320 Executive Court, Hillsborough, NC 27278. Copies of the contract, specifications and plans may be obtained by contacting **Kaylee Fender**, with Summit Design and Engineering Services at [kaylee.fender@summitde.com](mailto:kaylee.fender@summitde.com). Hard copies of these contract documents shall require a \$50.00 non-refundable payment. Summit accepts major credit cards and cashier’s checks. Electronic copies are available at no charge by contacting **Kaylee Fender**, with Summit Design and Engineering Services at [kaylee.fender@summitde.com](mailto:kaylee.fender@summitde.com).

## **INFORMATION FOR BIDDERS**

BIDS will be received by Jovana Amaro at 131 West Margaret Lane, Suite 300, Hillsborough, NC 27278 until **3:00 PM EST on April 29<sup>th</sup>, 2026**. BIDS may be mailed or delivered to said address.

Orange County – Little River Park hereinafter will be called the “OWNER”

All BIDS must be made on the required BID form. All blank spaces for BID prices must be filled in, in ink or typed, and the BID form must be fully completed and executed when submitted. Only one copy of the BID form is required.

The OWNER may waive any informalities or minor defects or reject any and all BIDS. Any BID may be withdrawn prior to the above scheduled time for the opening of BIDS or authorized postponement thereof. Any BID received after the time and date specified shall not be considered. No BIDDER may withdraw a BID within 60 days after the actual date of the opening thereof. Should there be reasons why the contract cannot be awarded within the specified period; the time may be extended by mutual agreement between the OWNER and the BIDDER.

BIDDERS must satisfy themselves of the accuracy of the estimated quantities in the BID Schedule by examination of the site and review of the drawings and specifications including ADDENDUMS.

The CONTRACT DOCUMENTS contain the provisions required for the construction of the PROJECT. Information obtained from an officer, agent, or employee of the OWNER or any other person shall not affect the risks or obligations assumed by the CONTRACTOR or relieve him from fulfilling any of the conditions of the contract.

A Bid BOND is required to be submitted along with the completed bid package. The Bid Bond is to be 5 percent of the total bid amount.

A performance BOND and a payment BOND, each in the amount of 100 percent of the CONTRACT PRICE, with a corporate Surety approved by the OWNER, will be required for the faithful performance of the contract.

Attorneys-in-fact who sign payment BONDS and performance BONDS must file with each BOND a certified and effective dated copy of the power of attorney.

The party to whom the contract is awarded will be required to execute the Agreement and obtain the performance BOND and payment BOND within ten (10) calendar days from the date when NOTICE OF AWARD is delivered to the BIDDER. In case of failure of the BIDDER in default, the BOND accompanying the proposal shall become the property of the OWNER.

Within ten (10) days of receipt of acceptable performance BOND and payment BOND, the OWNER shall sign the Agreement and return to such party whom the contract was awarded an executed duplicate of the Agreement. Should the OWNER not execute the Agreement within such period, the

BIDDER may with WRITTEN NOTICE, withdraw his signed Agreement. Such notice of withdrawal shall be effective upon receipt of the notice by the OWNER.

The NOTICE TO PROCEED shall be issued within ten (10) days of the execution of the Agreement by the OWNER. If the NOTICE TO PROCEED has not been issued within the ten (10) day period or within the period mutually agreed upon, the CONTRACTOR may terminate the Agreement without further liabilities on the part of either party.

The OWNER may make sure such investigations as he/she deems necessary to determine the ability of the BIDDER to perform the WORK, and the BIDDER shall furnish to the OWNER all such information and data for this purpose as the OWNER may request. The OWNER reserves the right to reject any BID if the evidence submitted proves incompetency of the contractor.

All applicable laws, ordinances, and the rules and regulations of all authorities having jurisdiction over construction of the PROJECT shall apply to the contract throughout.

Each BIDDER is responsible for inspecting the site and for reading and being thoroughly familiar with the CONTRACT DOCUMENTS. The failure or omission of any BIDDER to do any of the foregoing shall in no way relieve any BIDDER from any obligation in respect to his BID.

The Awarded BIDDER shall supply the names and addresses of major material SUPPLIERS and SUBCONTRACTORS when requested to do so by the OWNER.

**BID DOCUMENT**

Resurfacing Contract  
Little River Park

Proposal of \_\_\_\_\_  
(hereinafter called "BIDDER") organized and existing under the Laws of the State of North Carolina,  
doing business as \_\_\_\_\_  
\_\_\_\_\_, to  
Orange County – Little River Park (hereinafter called "OWNER").

*\*Insert "a corporation," "a partnership," or "an individual" as applicable.*

In compliance with your Advertisement for BIDS, BIDDER hereby proposes to perform all WORK, in strict accordance with the CONTRACT DOCUMENTS, within the time set forth therein, and at the prices listed below.

By permission of this BID, each BIDDER certifies, and in the case of a joint BID, each party thereto certifies as to his own organization, that this BID has been arrived at independently, without consultation, communication, or agreement as to any matter relating to this BID with any other BIDDER or with competitor.

BIDDER hereby agrees to commence WORK under this contract on or before a date to be specified in the NOTICE TO PROCEED and to fully complete the PROJECT within the specified consecutive calendar days thereafter, as provided in the General Conditions and the Bid Schedule. BIDDER further agrees to pay as liquidated damages the amount stated in the Bid Schedule for each consecutive calendar day work is done beyond the completion date, as provided in the General Conditions.

BIDDER acknowledges receipt of the following ADDENDUM:

\_\_\_\_\_  
\_\_\_\_\_  
\_\_\_\_\_

BIDDER agrees to perform all the work described in the CONTRACT DOCUMENTS for the following unit prices or lump sum: \_\_\_\_\_  
\_\_\_\_\_

NOTE: BIDS shall include sales tax and all other applicable taxes and fees. Contracts will be awarded on the basis of low bid.

If Bidder is:

An Individual

Name(type or print): \_\_\_\_\_

By: \_\_\_\_\_(SEAL)

Doing business as: \_\_\_\_\_

Business address: \_\_\_\_\_

Phone: \_\_\_\_\_ Fax: \_\_\_\_\_

A Partnership

Partnership Name: \_\_\_\_\_(SEAL)

By: \_\_\_\_\_  
(Signature of general Partner – attach evidence of authority to sign)

Name(type or print): \_\_\_\_\_

Business Address: \_\_\_\_\_

Phone: \_\_\_\_\_ Fax: \_\_\_\_\_

A Corporation

Corporation Name: \_\_\_\_\_

State of Incorporation: \_\_\_\_\_

Type \_\_\_\_\_  
(General Business, Professional, Service, LLC)

By: \_\_\_\_\_  
(Signature – attach evidence of authority to sign)

Name(type or print): \_\_\_\_\_

Title: \_\_\_\_\_

Attest: \_\_\_\_\_ (CORPORATE SEAL)

Business Address:

\_\_\_\_\_  
Phone: \_\_\_\_\_ Fax: \_\_\_\_\_

Date of Qualification to do business: \_\_\_\_\_

## LITTLE RIVER PARK BID FORM

ITEM	SPEC SECTION	DESCRIPTION	QUANTITY	UNIT	UNIT PRICE	AMOUNT BID
1	800	Mobilization	1.00	LS		
2	610	Asphalt Conc. Surface Course, Type S9.5B	935.00	TNS		
3	607	Incidental Milling	40.00	SY		
4	SP	Asphalt Removal/Tree Root	155.00	SY		
5	SP	ADA Concrete Parking Pavement	16.00	CY		
6	SP	Remove and Replace Wooden Wheel Bump Stops (4x6)	40.00	EA		
7	SP	Truncated Domes	2.00	EA		
8	SP	Install 15" Drainage Pipe	23.00	LF		
9	SP	Gravel #67 Stone	576.00	SY		
10	SP	Surface Mounted Speed Bumps	3.00	EA		
11	1205	Handicap Symbols	4.00	EA		
12	1205	4" White Pavement Marking Lines	1,075.00	LF		
13	1205	24" White Pavement Marking Lines	48.00	LF		
14	1205	Paint Symbols (Arrows)	4.00	EA		
15	SP	1.5" Borrow	50.00	CY		
16	SP	Pedestrian Crossing Sign	1.00	EA		

***TOTAL BID FOR PROJECT:***

**ADD ALTERNATE NO 1:**

ITEM	SPEC SECTION	DESCRIPTION	QUANTITY	UNIT	UNIT PRICE	AMOUNT BID
1	600	ASPHALT ADA PARKING PAVEMENT, S9.5B	8.00	TNS		

***TOTAL BID FOR ADD ALTERNATE NO. 1 : \_\_\_\_\_***

CONTRACTOR \_\_\_\_\_

ADDRESS \_\_\_\_\_

Federal Identification Number \_\_\_\_\_ Contractors License Number \_\_\_\_\_

Authorized Agent \_\_\_\_\_ Title \_\_\_\_\_

Signature \_\_\_\_\_ Date \_\_\_\_\_

Witness \_\_\_\_\_ Title \_\_\_\_\_

Signature \_\_\_\_\_ Date \_\_\_\_\_

## LIST OF SUBCONTRACTORS

All Bidders shall provide the following information regarding all subcontractors.

Subcontractor	Address	Phone

**BID BOND  
ORANGE COUNTY - LITTLE  
RIVER PARK RESURFACING**

Principal: \_\_\_\_\_  
Name of Principal Contractor

Surety: \_\_\_\_\_  
Name of Surety

Contract Number: \_\_\_\_\_ County: \_\_\_\_\_

Date of Bid: \_\_\_\_\_

KNOW ALL MEN BY THESE PRESENTS, That we, the PRINCIPAL CONTRACTOR (hereafter, PRINCIPAL) and SURETY above named, are held and firmly bound unto the Department of Transportation in the full and just sum of five (5) percent of the total amount bid by the Principal for the project stated above, for the payment of which sum well and truly to be made, we bind ourselves, our heirs, executors, administrators, and successors, jointly and severally, firmly by these presents.

NOW, THEREFORE, the condition of this obligation is: the Principal shall not withdraw its bid within sixty (60) days after the opening of the bids, or within such other time period as may be provided in the proposal, and if the Board of Transportation shall award a contract to the Principal, the Principal shall, within fourteen (14) calendar days after written notice of award is received by him, provide bonds with good and sufficient surety, as required for the faithful performance of the contract and for the protection of all persons supplying labor, material, and equipment for the prosecution of the work. In the event the Principal requests permission to withdraw his bid due to mistake in accordance with the provisions of Article 103-3 of the *Standard Specifications for Roads and Structures*, the conditions and obligations of this Bid Bond shall remain in full force and effect until the Department of Transportation makes a final determination to either allow the bid to be withdrawn or to proceed with award of the contract. In the event a determination is made to award the contract, the Principal shall have fourteen (14) calendar days to comply with the requirements set forth above. In the event the Principal withdraws its bid after bids are opened except as provided in Article 103-3, or after award of the contract has been made fails to execute such additional documents as may be required and to provide the required bonds within the time period specified above, then the amount of the bid bond shall be immediately paid to the Department of Transportation as liquidated damages.

IN TESTIMONY WHEREOF, the Principal and Surety have caused these presents to be duly signed and sealed.

This the \_\_\_\_\_ day of \_\_\_\_\_, 20 \_\_\_\_\_

\_\_\_\_\_  
Surety

By \_\_\_\_\_  
General Agent or Attorney-in-Fact Signature

*Seal of Surety*

\_\_\_\_\_  
Print or type Signer's Name

**BID BOND**

**CORPORATION**

SIGNATURE OF CONTRACTOR (Principal)

---

Full name of Corporation

---

Address as prequalified

By

---

**Signature of President, Vice President, Assistant Vice President**

*Select appropriate title*

---

Print or type Signer's name

*Affix Corporate Seal*

Attest

---

Signature

*Select appropriate title*

---

Print or type Signer's name

**BID BOND**

**LIMITED LIABILITY COMPANY**

SIGNATURE OF CONTRACTOR (Principal)

Name of Contractor

\_\_\_\_\_

Full name of Firm

\_\_\_\_\_

Address as prequalified

**Signature of Member/  
Manager/Authorized Agent**

\_\_\_\_\_

Individually

\_\_\_\_\_

Print or type Signer's name

**BID BOND**

**INDIVIDUAL DOING BUSINESS UNDER A FIRM NAME**

SIGNATURE OF CONTRACTOR (Principal)

Name of Contractor

\_\_\_\_\_   
 Individual Name

Trading and doing business as

\_\_\_\_\_   
 Full name of Firm

\_\_\_\_\_   
 Address as prequalified

Signature of Contractor

\_\_\_\_\_   
 Individually

\_\_\_\_\_   
 Print or type Signer's name

\_\_\_\_\_   
 Signature of Witness

\_\_\_\_\_   
 Print or type Signer's name

**BID BOND**

**INDIVIDUAL DOING BUSINESS IN HIS OWN NAME**

SIGNATURE OF CONTRACTOR (Principal)

Name of Contractor

\_\_\_\_\_

Print or type Individual Name

\_\_\_\_\_

Address as prequalified

Signature of Contractor

\_\_\_\_\_

Individually

\_\_\_\_\_

Print or type Signer's name

\_\_\_\_\_

Signature of Witness

\_\_\_\_\_

Print or type Signer's name

**BID BOND**

**PARTNERSHIP**

SIGNATURE OF CONTRACTOR (Principal)

---

Full name of Partnership

---

Address as prequalified

By \_\_\_\_\_  
Signature of Partner

\_\_\_\_\_  
Print or type Signer's name

---

Signature of Witness

---

Print or type Signer's name

**BID BOND**  
**JOINT VENTURE (2 or 3)**  
SIGNATURE OF CONTRACTORS (Principal)

Instructions to Bidders: **2 Joint Ventures**, Fill in lines (1), (2) and (3) and execute. **3 Joint Venturers** Fill in lines (1), (2), (3), (4) and execute. Line (1), print or type the name of Joint Venture. On line (2), print or type the name of one of the joint venturers and execute below in the appropriate manner required by Article 102-8 of the *Specifications*. On Line (3), print or type the name of second joint venturer and execute below in the appropriate manner required by said article of the Specifications. On Line (4), print or type the name of the third joint venturer, if applicable and execute below in the appropriate manner required by said article of the Specifications. This form of execution must be strictly followed.

(1) \_\_\_\_\_  
Name of Joint Venture

(2) \_\_\_\_\_  
Name of Contractor

\_\_\_\_\_  
Address as prequalified

_____ Signature of Witness or Attest	By	_____ Signature of Contractor
_____ Print or type Signer's name		_____ Print or type Signer's name

*If Corporation, affix Corporate Seal*

and

(3) \_\_\_\_\_  
Name of Contractor

\_\_\_\_\_  
Address as prequalified

_____ Signature of Witness or Attest	By	_____ Signature of Contractor
_____ Print or type Signer's name		_____ Print or type Signer's name

*If Corporation, affix Corporate Seal*

and

(4) \_\_\_\_\_  
Name of Contractor *(for 3 Joint Venture only)*

\_\_\_\_\_  
Address as prequalified

_____ Signature of Witness or Attest	By	_____ Signature of Contractor
_____ Print or type Signer's name		_____ Print or type Signer's name

*If Corporation, affix Corporate Seal*

**CONTRACT PAYMENT BOND  
ORANGE COUNTY - LITTLE  
RIVER PARK RESURFACING**

Date of Payment Bond Execution \_\_\_\_\_

Name of Principal Contractor \_\_\_\_\_

Name of Surety: \_\_\_\_\_

Name of Contracting Body: \_\_\_\_\_

\_\_\_\_\_

Amount of Bond: \_\_\_\_\_

Contract ID No.: \_\_\_\_\_

County Name: \_\_\_\_\_

KNOW ALL MEN BY THESE PRESENTS, That we, the PRINCIPAL CONTRACTOR (hereafter, PRINCIPAL) and SURETY above named, are held and firmly bound unto the above named Contracting Body, hereinafter called the Contracting Body, in the penal sum of the amount stated above for the payment of which sum well and truly to be made, we bind ourselves, our heirs, executors, administrators, and successors, jointly and severally, firmly by these presents.

THE CONDITION OF THIS OBLIGATION IS SUCH, that whereas the principal entered into a certain contract with the Contracting Body, numbered as shown above and hereto attached:

NOW THEREFORE, if the principal shall promptly make payment to all persons supplying labor and material in the prosecution of the work provided for in said contract, and any and all duly authorized modifications of said contract that may hereafter be made, notice of which modifications to the surety being hereby waived, then this obligation to be void; otherwise to remain in full force and virtue.

IN WITNESS WHEREOF, the above-bound parties have executed this instrument under their several seals on the date indicated above, the name and corporate seal of each corporate party being hereto affixed and these presents duly signed by its undersigned representative, pursuant to authority of its governing body.

**CONTRACT PAYMENT BOND**

*Affix Seal of Surety Company*

\_\_\_\_\_  
Print or type Surety Company Name

By

\_\_\_\_\_  
Print, stamp or type name of Attorney-in-Fact

\_\_\_\_\_  
Signature of Attorney-in-Fact

\_\_\_\_\_  
Signature of Witness

\_\_\_\_\_  
Print or type Signer's name

\_\_\_\_\_  
Address of Attorney-in-Fact

**CONTRACT PAYMENT BOND**  
**CORPORATION**

SIGNATURE OF CONTRACTOR (Principal)

---

Full name of Corporation

---

Address as prequalified

By \_\_\_\_\_  
Signature of **President, Vice President, Assistant Vice President**  
*Select appropriate title*

---

Print or type Signer's name

*Affix Corporate Seal*

Attest

---

Signature of **Secretary, Assistant Secretary**  
*Select appropriate title*

---

Print or type Signer's name

Contract No. \_\_\_\_\_  
County \_\_\_\_\_

Rev. 4-19-11

**CONTRACT PAYMENT BOND**

**LIMITED LIABILITY COMPANY**

SIGNATURE OF CONTRACTOR (Principal)

Name of Contractor

\_\_\_\_\_  
Full name of Firm

\_\_\_\_\_  
Address as prequalified

By:

\_\_\_\_\_  
**Signature of Member, Manager, Authorized Agent**  
*Select appropriate title*

\_\_\_\_\_  
Print or type Signer's name

Contract No. \_\_\_\_\_  
County \_\_\_\_\_

Rev. 4-19-11

**CONTRACT PAYMENT BOND**

**INDIVIDUAL DOING BUSINESS UNDER A FIRM NAME**

SIGNATURE OF CONTRACTOR (Principal)

Name of Contractor \_\_\_\_\_  
Individual Name

Trading and doing business as \_\_\_\_\_  
Full name of Firm

\_\_\_\_\_  
Address as prequalified

Signature of Contractor \_\_\_\_\_  
Individually

\_\_\_\_\_  
Print or type Signer's name

\_\_\_\_\_  
Signature of Witness

\_\_\_\_\_  
Print or type Signer's name

Contract No. \_\_\_\_\_  
County \_\_\_\_\_

Rev. 4-19-11

**CONTRACT PAYMENT BOND**

**INDIVIDUAL DOING BUSINESS IN HIS OWN NAME**

SIGNATURE OF CONTRACTOR (Principal)

Name of Contractor \_\_\_\_\_  
Print or type Individual name

\_\_\_\_\_  
Address as prequalified

Signature of Contractor \_\_\_\_\_  
Individually

\_\_\_\_\_  
Print or type Signer's name

\_\_\_\_\_  
Signature of Witness

\_\_\_\_\_  
Print or type Signer's name

Contract No. \_\_\_\_\_  
County \_\_\_\_\_

Rev. 4-19-11

**CONTRACT PAYMENT BOND**  
**PARTNERSHIP**

SIGNATURE OF CONTRACTOR (Principal)

\_\_\_\_\_  
Full name of Partnership

\_\_\_\_\_  
Address as prequalified

By \_\_\_\_\_  
Signature of Partner

\_\_\_\_\_  
Print or type Signer's name

\_\_\_\_\_  
Signature of Witness

\_\_\_\_\_  
Print or type Signer's name



Contract No. \_\_\_\_\_  
County \_\_\_\_\_

Rev. 4-19-11

**CONTRACT PAYMENT BOND**

Attach certified copy of Power of Attorney to this sheet

**CONTRACT PERFORMANCE BOND**  
**ORANGE COUNTY - LITTLE**  
**RIVER PARK RESURFACING**

Date of Performance Bond Execution: \_\_\_\_\_

Name of Principal Contractor: \_\_\_\_\_

Name of Surety: \_\_\_\_\_

Name of Contracting Body: \_\_\_\_\_

Amount of Bond: \_\_\_\_\_

Contract ID No.: \_\_\_\_\_

County Name: \_\_\_\_\_

KNOW ALL MEN BY THESE PRESENTS, That we, the PRINCIPAL CONTRACTOR (hereafter, PRINCIPAL) and SURETY above named, are held and firmly bound unto the above named Contracting Body, hereinafter called the Contracting Body, in the penal sum of the amount stated above for the payment of which sum well and truly to be made, we bind ourselves, our heirs, executors, administrators, and successors, jointly and severally, firmly by these presents.

THE CONDITION OF THIS OBLIGATION IS SUCH, that whereas the principal entered into a certain contract with the Contracting Body, numbered as shown above and hereto attached:

NOW THEREFORE, if the principal shall well and truly perform and fulfill all the undertakings, covenants, terms, conditions, and agreements of said contract with respect to the design, preconstruction work, construction and twelve month guarantee, hereinafter called the Construction Phase, of said contract and any extensions thereof that may be granted by the Contracting Body, with or without notice to the Surety, and during the life of any guaranty required under the contract, and shall also well and truly perform and fulfill all the undertakings, covenants, terms, conditions, and agreements of any and all duly authorized modifications of said contract in respect to the Construction Phase that may hereafter be made, notice of which modifications to the surety being hereby waived, then this obligation to be void; otherwise to remain in full force and virtue.

IN WITNESS WHEREOF, the above-bound parties have executed this instrument under their several seals on the date indicated above, the name and corporate seal of each corporate party being hereto affixed and these presents duly signed by its undersigned representative, pursuant to authority of its governing body.

**CONTRACT PERFORMANCE BOND**

*Affix Seal of Surety Company*

\_\_\_\_\_  
Print or type Surety Company Name

By

\_\_\_\_\_  
Print, stamp or type name of Attorney-in-Fact

\_\_\_\_\_  
Signature of Attorney-in-Fact

\_\_\_\_\_  
Signature of Witness

\_\_\_\_\_  
Print or type Signer's name

\_\_\_\_\_  
Address of Attorney-in-Fact

**CONTRACT PERFORMANCE BOND**

**LIMITED LIABILITY COMPANY**

SIGNATURE OF CONTRACTOR (Principal)

Name of Contractor

\_\_\_\_\_

Full name of Firm

\_\_\_\_\_

Address as prequalified

Signature of Member/Manager

\_\_\_\_\_

Individually

\_\_\_\_\_

Print or type Signer's name

**NORTH CAROLINA**

**CONSTRUCTION AGREEMENT OVER \$250,000.00**

**ORANGE COUNTY**

THIS CONSTRUCTION AGREEMENT (hereinafter called "Agreement"), made as of the \_\_\_\_\_ day of \_\_\_\_\_, 20\_\_\_\_, by and between \_\_\_\_\_, (hereinafter called the "Contractor"), and Orange County, a political subdivision of the State of North Carolina, (hereinafter called the "County," "Orange County," or "Owner").

**WITNESSETH:**

That the Contractor and the Owner, for the consideration herein named, agree as follows:

**1. CONTRACT DOCUMENTS; PRIORITY**

The Contract Documents consist of this Agreement, the General Conditions which are fully incorporated in this Agreement, the Request for Proposals, designer approved communications and field orders, the Proposal, Construction Documents and Drawings and Written Specifications. The Contract Documents form the Contract. In the event of any inconsistency between or among the Contract Documents the Contract Documents shall be interpreted in the following order of priority:

- a. This Agreement and incorporated General Conditions attached as Exhibit 1.
- b. Designer approved and stamped construction documents and drawings and written specifications.
- c. Designer approved communications and field orders.
- d. Request for Proposals and addenda thereto.
- e. Proposal.

**2. SCOPE OF WORK**

The Contractor shall furnish and deliver all of the materials, and perform, and be fully responsible for all of the Work required by this Agreement within the time period stipulated in a written Notice-to-Proceed to be executed by the Contractor and Owner and in accordance with the following enumerated documents, which are made a part hereof as if fully contained herein:

- a. Construction Drawings prepared by \_\_\_\_\_ (Sheet \_\_\_\_\_ dated \_\_\_\_\_)
- b. Written specifications prepared by the Designer.
- c. \_\_\_\_\_ proposal dated \_\_\_\_\_, 20\_\_\_\_ which fully describes the work to be performed, such work (hereinafter called the "Work").

- d. Related documents listed under Section 1 above.

**3. TERM AND SCHEDULING**

- a. The Contractor agrees to commence work pursuant to the written Notice-to Proceed.
- b. The Contractor agrees to complete substantially all Work included by \_\_\_\_\_, 20\_\_\_\_.
- c. Time is of the essence with respect to all dates specified in the Contract Documents as Completion Dates.
- d. The Contractor shall perform the Work in the time, manner and form required by the Contract Documents and as stipulated in a written Notice-to-Proceed to be executed by the Contractor and Owner.

**4. STANDARD OF CARE AND DUTIES OF CONTRACTOR**

- a. The Contractor shall exercise reasonable care and diligence in performing the Work in accordance with the generally accepted standards of this type of Contractor practice throughout the United States and in accordance with applicable federal, state and local laws and regulations applicable to the performance of these services. Contractor is solely responsible for the professional quality, accuracy, timely completion, and submission of all work.
- b. The Contractor shall not load or permit any part of the Work to be loaded with a weight that will endanger its safety, intended performance or configuration.
- c. Contractor shall be responsible for all Contractor, Subcontractor, and Sub-subcontractor errors or omissions, in the performance of the Agreement together with the errors and omissions of any agent or employee of the Contractor or any Subcontractor or Sub-subcontractor. Contractor shall correct any and all errors, omissions, discrepancies, ambiguities, mistakes, or conflicts at no additional cost to the Owner.
- d. Contractor is an independent contractor of Owner. Any and all employees of the Contractor engaged by the Contractor in the performance of any work or services required of the Contractor under this Agreement, shall be considered employees or agents of the Contractor only and not of the Owner, and any and all claims that may or might arise under any workers compensation or other law or contract on behalf of said employees while so engaged shall be the sole obligation and responsibility of the Contractor.
- e. Contractor shall at all times remain in compliance with all applicable local, state, and federal laws, rules, and regulations including but not limited to all state and federal non-discrimination laws, policies, rules, and regulations and the Orange County Non-Discrimination Policy and Orange County Living Wage Policy (each Orange County policy is incorporated herein by reference \_\_\_\_\_ and \_\_\_\_\_ may \_\_\_\_\_ be \_\_\_\_\_ viewed \_\_\_\_\_ at [http://www.orangecountync.gov/departments/purchasing\\_division/contracts.php](http://www.orangecountync.gov/departments/purchasing_division/contracts.php)). Any violation of the Orange County Non-Discrimination Policy is a breach of this Agreement and County may immediately terminate this Agreement without further obligation on the part of the County. This paragraph is not intended to limit and does not limit the definition of breach to discrimination.

- f. If activities related to the performance of this Agreement require specific licenses, certifications, or related credentials Contractor represents that it and its employees, agents and subcontractors engaged in such activities possess such licenses, certifications, or credentials and that such licenses certifications, or credentials are current, active, and not in a state of suspension or revocation.
- g. The Contractor shall supervise and direct the Work efficiently and with the Contractor's best skill and attention. Except as specifically set forth in the Contract Documents the Contractor shall be solely responsible for the means, methods, techniques, sequences, and procedures of construction, and for safety precautions and programs in connection with the Work. The Contractor shall be responsible to see that the finished Work complies accurately with the Contract Documents.
- h. The Contractor shall appoint a competent Project Manager with general authority to manage the Project for the Contractor. The Contractor shall also keep on the Project at all times during the Work of the Contractor a competent Resident Superintendent and necessary assistants who shall not be replaced without prior written approval by the Designer or by the Owner if a Designer is not retained for the Project.
- i. If, in the opinion of the Designer, any Subcontractor on the Project is incompetent or otherwise unsatisfactory, such Subcontractor shall be replaced by the Contractor with no increase in the Contract Price if and when directed by the Designer.
- j. The Contractor shall attend all progress conferences and all other meetings or conferences. The Contractor shall be represented at these progress conferences by a representative having the authority of the Project Manager and by such other representatives as the Designer may direct.
- k. Costs and expenses of providing samples for and assistance in any testing shall be borne by the Contractor. Any Work in which untested materials are used without written approval or written permission of the Owner or Designer shall be removed and replaced at Contractor's expense.
- l. The Contractor shall obtain all necessary permits including all permits required to complete the Work in compliance with local, state, and federal law.

## 5. PAYMENT & TAXES

- a. The Owner hereby agrees to pay to the Contractor for the faithful performance of this Agreement, and the Contractor hereby agrees to perform all of the Work for a sum not-to-exceed        Dollars (\$        ). Not later than the fifth (5th) day of each calendar month the Contractor shall submit to the Owner's Representative, generally the Designer if a Designer is retained on the Work, a Request for Payment for work done during the previous calendar month.
  - (i) The Request for Payment shall be in form of a standardized invoice or AIA Document G702-703 appropriately addressed to Owner's Representative at        and shall show substantially the value of work done during the previous calendar month.

- (ii) The amount due for payment shall be ninety-five percent (95%) of the value of work completed since the last Request for Payment and this amount shall be paid by the Owner on or before the last business day of the month. Owner shall retain five percent (5%) (the “Retainage”).
    - (1) Upon Owner’s Representative’s certification that fifty percent (50%) of the Work has been satisfactorily completed Retainage shall be reduced to two and one half percent (2½%).
    - (2) Upon Owner’s Representative’s certification that ninety percent (90%) of the Work has been satisfactorily completed Retainage may be discontinued. Retainage may be discontinued, at Owner’s Discretion, so long as work continues to be completed satisfactorily and on schedule.
    - (3) The Owner may discontinue withholding retainage in accordance with the provisions of NCGS-143-(b1)(2) when the project is 50% complete.
  - (iii) Final payment shall not be due to the Contractor until thirty (30) days after Final Completion of the Work, including punch list work, has been satisfactorily (as determined by the County) completed and an appropriate Affidavit, Indemnification, and Release as required in Section 5.4(e) of Exhibit 1 has been received and approved by Owner.
- b. Should Owner reasonably determine that Contractor has failed to perform the Work related to a Request for Payment, Owner, at its discretion may provide the Contractor ten (10) days to cure the breach. Owner may withhold the accompanying payment without penalty until such time as Contractor cures the breach.
- (i) Should Contractor or its representatives fail to cure the breach within ten (10) days, or fail to reasonably agree to such modified schedule, Owner may immediately terminate this Agreement in writing, without penalty or incurring further obligation to Contractor.
  - (ii) This section shall not be interpreted to limit the definition of breach to the failure to perform the Work related to a Request for Payment.
- c. The Contractor has included in the Contract Price and shall pay all taxes assessed by any authority on the Work or the labor and materials used therein. It shall be the Contractor's responsibility to furnish the Owner documentary evidence showing the materials used and sales and use tax paid by the Contractor and each of its subcontractors.
- d. Should the Owner receive notice that the Contractor has failed to pay a Subcontractor for the Work performed related to a Request for Payment, Owner shall have the authority to withhold payment of the disputed amount until parties resolve their dispute. Failure to pay the Contractor pursuant to this section of the Agreement shall not be deemed to be a breach of the Agreement.

**6. NON-APPROPRIATION**

- a. Contractor acknowledges that Owner is a governmental entity, and the validity of this Agreement is based upon the availability of public funding under the authority of its statutory mandate.
- b. In the event that public funds are unavailable or not appropriated for the performance of Owner's obligations under this Agreement, then this Agreement shall automatically expire without penalty to Owner immediately upon written notice to Contractor of the unavailability or non-appropriation of public funds. It is expressly agreed that Owner shall not activate this non-appropriation provision for its convenience or to circumvent the requirements of this Agreement.
- c. In the event of a change in the Owner's statutory authority, mandate or mandated functions, by state or federal legislative or regulatory action, which adversely affects Owner's authority to continue its obligations under this Agreement, then this Agreement shall automatically terminate without penalty to Owner upon written notice to Contractor of such limitation or change in Owner's legal authority.

**7. NOTICES**

Any notice required by this Agreement shall be in writing and delivered by certified or registered mail, return receipt requested to the following:

<p>Owner:          Orange County          Attn:          P.O. Box 8181          Hillsborough, NC 27278</p>	<p>Contractor:</p>
--	--------------------

**8. MISCELLANEOUS**

- a. Duties and Obligations imposed by the Contract Documents shall be in addition to any Duties and Obligations imposed by state, federal or local law, rules, regulations and ordinances.
- b. No act or failure to act by the Owner or Contractor shall constitute a waiver of any right or duty granted them under the Contract Documents, nor shall any act or failure to act constitute any approval except as specifically agreed in writing.
- c. The Work shall be tested and inspected as required by the Contract Documents and as required by law. Unless prohibited by law the costs of all such tests and inspections related to state and federal codes such as ADA, Administrative, Electrical, Plumbing, Mechanical and Building Codes shall be borne by the Contractor. The costs for material and structural testing shall be conducted by an independent third party at the expense of the Owner. Delays related to any of the aforementioned tests and inspections shall not be grounds for delaying the completion of the work. If any such tests and inspections reveal deficiencies in the Work such that the Work does not comply with terms or requirements of the Contract Documents and the requirements of any code or law the Contractor is solely responsible for the cost of bringing such deficiencies into compliance with the terms of the Contract Documents and any code or law.
- d. Should the Designer, if a Designer is retained for the project involving the Work, or Owner reject any portion of the Work for failing to comply with the Contract Documents Contractor

shall immediately, at Contractor's expense, correct the Work. Any such rejection may be made before or after substantial completion. If applicable, any additional expense borne by the Designer under this section shall be paid at Contractor's expense.

- e. The County has designated ( ) to act as the County's representative with respect to the Project and shall have the authority to render decisions within guidelines established by the County Manager or the County Board of Commissioners and shall be available during working hours as often as may be reasonably required to render decisions and to furnish information.
- f. The Contractor shall not assign any portion of this Agreement nor subcontract the Work in its entirety without the prior written consent of the Owner.
- g. In the event of a breach by Contractor Owner has sole authority to determine the reasonableness of Contractor's actions to remedy such breach or complete the performance of its obligations.
- h. Upon request of the Owner, the Contractor shall submit to County all relevant documentation, including but not limited to, job cost records, to support its claims for final compensation and if such request is made final compensation shall not be due until all relevant documentation is received, reviewed, and approved by Owner.

## **9. CONSEQUENTIAL DAMAGES**

- a. Owner and Contractor mutually waive any claim against each other for consequential damages. Consequential Damages include:
  - (i) Damages incurred by Owner for loss of use, income, financing, or business.
  - (ii) Damages incurred by Contractor for office expenses, including personnel, loss of financing, profit, income, business, damage to reputation, or any other non-direct damages.

## **10. ENTIRE AGREEMENT**

All of the documents listed, referenced or described in this Agreement, the written Notice-to-Proceed, together with Modifications made or issued in accordance herewith are the Contract Documents, and the work, labor, materials, and completed construction required by the Contract Documents and all parts thereof is the Work. The Contract Documents constitute the entire agreement between Owner and Contractor. This Agreement may be amended only by written instrument signed by both parties. Modifications may be evidenced by facsimile signatures. If any provision of the Agreement or General Conditions shall be declared invalid or unenforceable, the remainder of the Agreement shall continue in full force and effect.

[SIGNATURE PAGE TO FOLLOW]

**IN WITNESS WHEREOF**, the Parties hereto have executed this Agreement as of the day and date first above written in a number of counterparts, each of which shall, without proof or accounting for other counterparts, be deemed an original contract.

**ORANGE COUNTY:**

**CONTRACTOR:**

By: \_\_\_\_\_

By: \_\_\_\_\_

*Printed Name and Title*

**ORANGE COUNTY—INTERNAL USE ONLY**

**Finance Information**

Vendor Name: \_\_\_\_\_ Vendor Contact Person: \_\_\_\_\_ Phone: \_\_\_\_\_ Address: \_\_\_\_\_ City \_\_\_\_\_ State: \_\_\_\_\_ Zip: \_\_\_\_\_  
Department: \_\_\_\_\_ Amount: \_\_\_\_\_ Purpose: \_\_\_\_\_ Budget Code(s): \_\_\_\_\_ Vendor # \_\_\_\_\_  
Vendor Status with NCSOS: \_\_\_\_\_ Vendor is a BOCC consultant:  Yes  No

**Contract Details**

Contract Type:  New  Amendment (Original Contract: \_\_\_\_\_) (Most Recent Amendment \_\_\_\_\_)  
Effective Date \_\_\_\_\_ End Date \_\_\_\_\_ Notice Date \_\_\_\_\_ (Notice Purpose \_\_\_\_\_)

**Award**

Approved by Board (Agenda Date: \_\_\_\_\_);  Made or Administered by \_\_\_\_\_

**Signature Authority**

- BOCC Express Delegation (Agenda Date: \_\_\_\_\_)
- Policy 9.4:  Under \$5,000;  Service Under \$90,000;  Construction Under \$250,000
- Budget Policy Section XV (Capital Improvement Project: \_\_\_\_\_)

**Bidding**

Informal Bidding (\$30k-\$90k);  Formal RFP (\$90k+);  Other (<\$30k);  Exception(# \_\_\_\_\_)

**Department Affirmation**

This agreement is approved as to technical form and content and I as Department Director affirmatively state work on this project has not been initiated prior to execution of the agreement; OR  
 This agreement is approved as to technical form and content. Services related to this agreement have already begun or been completed. Description of the nature of the emergency condition that was addressed:

**Department Director's Signature** \_\_\_\_\_ **Date:** \_\_\_\_\_

**Information Technologies**

This agreement has been reviewed and is approved as to information technology content and specifications:

**Office of the Chief Information Officer** \_\_\_\_\_ **Date:** \_\_\_\_\_

*Inapplicable because no hardware/software purchases or related services*

**Risk Management**

This agreement is approved for sufficiency of insurance standards, specifications, and requirements:

**Office of the Risk Management Officer** \_\_\_\_\_ **Date:** \_\_\_\_\_

**Financial Services**

This instrument has been pre-audited in the manner required by the Local Government Budget and Fiscal Control Act:

**Office of the Chief Financial Officer** \_\_\_\_\_ **Date:** \_\_\_\_\_

**Legal Services**

This agreement is approved as to legal form and sufficiency:

**Office of the County Attorney** \_\_\_\_\_ **Date:** \_\_\_\_\_

**Clerk to the Board**

All DocuSign contracts must be copied to the Clerk upon completion: [occlerkdocs@orangecountync.gov](mailto:occlerkdocs@orangecountync.gov)

The following signature block is for hard copies only and is not required for DocuSign contracts:

Received for record retention:

**Office of the Clerk to the Board** \_\_\_\_\_ **Date:** \_\_\_\_\_

## EXHIBIT 1----GENERAL CONDITIONS

Table of Contents	Page
Article 1. Definitions.....	3
Article 2. Correlation, Interpretation, and Intent of Contract Documents.....	7
Article 3. Familiarity with Work, Conditions and Laws.....	8
Article 4. Bonds.....	9
Article 5. Insurance and Indemnity .....	9
Article 6. Other Record Documents and Submittals.....	16
Article 7. Contractor.....	18
Article 8. Owner .....	26
Article 9. Construction Manager .....	26
Article 10. Designer .....	26
Article 11. Testing and Surveying.....	27
Article 12. Separate Contracts.....	27
Article 13. Contract Time .....	28
Article 14. Changes in the Work .....	31
Article 15. Change of the Contract Price .....	33
Article 16. Unforeseen Conditions.....	35
Article 17. Correction of Work before Final Payment .....	35
Article 18. Correction of Work after Substantial Completion; Warranties and Guaranties.....	36
Article 19. Owner's Right to Do Work .....	37
Article 20. Partial Payments .....	37
Article 21. Final Payment.....	40
Article 22. Contractor, Subcontractor and Supplier Affidavit .....	41
Article 23. Assignments and Subcontracts.....	41

Article 24. Measurements.....	41
Article 25. Contractor and Subcontractor Relationships.....	42
Article 26. Use of Premises .....	42
Article 27. Cutting, Patching and Fitting .....	42
Article 28. Dispute Resolution .....	43
Article 29. Taxes.....	43
Article 30. Operation of Owner's Facilities.....	44
Article 31. Third Party Beneficiary Clause.....	44
Article 32. Measurement of Quantities .....	44
Article 33. Termination by the Owner for Cause .....	44
Article 34. Termination or Suspension by the Owner for Convenience.....	45
Article 35. Minority Business Enterprise Program.....	46
Article 36 E-Verify, Iran Divestment, Israel Boycott, and Digital.....	46
Article 37. General.....	46

## **ARTICLE 1. DEFINITIONS**

1.1 Agreement - The Construction Contract, these General Conditions, and any Supplementary Conditions.

1.2 AIA - The American Institute of Architects.

1.3 ASTM - The American Society for Testing and Materials.

1.4 Beneficial Occupancy – Use of the Project by the Owner after Substantial Completion, but prior to Final Completion..

1.5 Change Order - A written order to the Contractor signed by the Owner and the Designer authorizing an addition, deletion, or revision in the Work or an adjustment in the Contract Price or the Contract Time issued after execution of the Construction Contract. See paragraph 14.1.

1.6 Completion Date - Those dates identified as Completion Dates in the Contract Construction Schedule or elsewhere in the Contract Documents.

1.7 Construction Contract – The document executed by the Contractor and the Owner to formally memorialize their consent to the terms of the Agreement.

1.8 Construction Change Directive – A written order to the Contractor signed by the Owner and the Designer directing an addition, deletion, or revision in the Work after execution of the Construction Contract, in circumstances when the parties have been unable to agree on an adjustment to the Contract Price or the Contract Time, but the Owner requests that the Contractor proceed with said addition, deletion, or revision in the Work subject to adjustment of the Contract Price or Contract Time under the procedures described herein.

1.9 Construction Manager(s) - The person(s) or firm designated as the Construction Manager in the Contract Documents, or their authorized representatives. The Construction Manager(s), as referred to herein, will be referred to hereinafter as if each were of the singular number and masculine gender.

1.10 Contract Construction Schedule - That schedule described in Article 13 hereof and identified as the Contract Construction Schedule.

1.11 Contract Documents - All of the documents that make up the Agreement, plus the Drawings and Specifications that describe the scope of the Work, plus allowable Modifications to the Contract Documents.

1.12 Contract Price - The total monies payable to the Contractor under the Contract Documents pursuant to paragraph 15.1 of the Agreement.

1.13 Contract Time - The number of calendar days stated in, or computed from, the Contract Documents for the completion of the Work, or any portion thereof. See, particularly, Article 13

hereof and the Contract Construction Schedule. Time of completion as specified therein is of the essence. The time used and referred to on the Project will be that time which is observed in Raleigh, North Carolina, being Eastern Daylight Savings Time (EDT), Eastern Standard Time (EST), or other as designated by the Designer.

1.14 Contractor - The Contractor shall be that party identified as such in the Contract Documents.

1.15 Days - Unless otherwise indicated, the term "days" shall mean consecutive calendar days.

1.16 Daylight Hours - The hours or portions of hours between sunrise and sunset local time.

1.17 Designer(s) – The person or firm designated as the Designer in the Contract Documents, or their authorized representatives. The Designer(s), as referred to herein, shall mean architect, landscape architect, or engineer. They will be referred to hereinafter as if each were of the singular number and masculine gender. On projects for which there is no Designer designated references to approvals or authorizations of or by the Designer shall be interpreted to refer to approvals or authorizations of Owner or Owner's designee.

1.18 Drawings - The Drawings are the graphic and pictorial portions of the Contract Documents, wherever located and whenever issued, showing the design, location, and dimensions of the Work, and generally including plans, elevations, sections, details, schedules and diagrams. A list of the Drawings is contained in the Contract Documents.

1.19 Field Order - A written order issued by the Designer which clarifies or interprets the Contract Documents or orders minor changes in the Work in accordance with the Contract Documents. See paragraph 14.2.

1.20 Final Completion - The point at which the Contractor has completed the Work, with the exception of guaranty and warranty obligations and as determined by the Designer and becomes entitled to final payment upon the recommendation of the Designer and determination by the Owner.

1.21 The words "furnish," "furnish and install," "install," and "provide" or words with similar meanings shall be interpreted, unless otherwise stated, to mean furnish and install complete, in place and ready for service.

1.22 Liquidated Damages – See paragraph 13.18 of these General Conditions.

1.23 Modification - (A) a written amendment to the Contract Documents signed by the Owner and the Contractor and identified therein as such, (B) a Change Order, (C) Construction Change Directive, or (D) a Field Order. A Modification may only be issued after execution of the Agreement.

1.24 Notice of Award - The written notice by the Owner to the Contractor that the Contractor is the successful Bidder and that upon compliance with the conditions precedent to be fulfilled by the Contractor within the time specified, the Owner will execute and deliver the Agreement to him.

1.25 Notice to Proceed - See paragraph 13.3.

1.26 Owner - The Owner is the person designated as such in the Agreement.

1.27 Owner's Representative - A person, or persons, authorized and employed by the Owner and designated from time to time by written notice to the Contractor to administer the Contract Documents, and to observe and monitor the Work on behalf of the Owner with authority and responsibility as herein specified.

1.28 Notice - The term "notice" or "written notice" as used herein shall mean and include all written notices, demands, instructions, and claims approvals and disapprovals furnished by the Owner or the Designer to obtain compliance with the requirements of the Contract Documents, as well as all written notices, demands, instructions and claims furnished by the Contractor as required by the Contract Documents. Where notice is required under the terms of the Contract Documents written notice shall always be required, and oral or "constructive" notice shall be insufficient and ineffective as notice. Email or other electronic delivery shall be insufficient and ineffective as notice unless specifically allowed by the Supplementary Conditions or a Modification to the Agreement. Written notice shall be deemed to have been duly served on the date that it is delivered in person to the individual or to a member of the firm, to an officer of the corporation for whom it is intended, to an authorized representative of such individual, firm, or corporation, or on the date that it is mailed by registered or certified mail, return receipt requested, addressed to the last business address of such individual, firm, or corporation known to the person giving the notice. Written notice may also be given by facsimile transmission, provided that proof of delivery is obtained. In the case of delivery in person, such delivery shall not be effective unless and until a written and signed receipt showing the date and time of delivery is obtained.

1.29 Project - The total construction of which the Work performed under the Contract Documents may be the whole or a part.

1.30 Project Expediter – As used herein, is an entity stated in the Contract Documents, designated to effectively facilitate scheduling and coordination of Work activities. For the purpose of a single prime contract, the single prime contractor is designated as the Project Expediter. For the purpose of a project involving separate prime contracts, the Contractor for general work shall be designated as the Project Expediter unless otherwise indicated in the Supplementary General Conditions. See paragraph 7.27.

1.31 Project Manager - That person designated by the Contractor in accordance with paragraph 7.2 who shall be in general charge of the Work and its performance and who shall have the authority set forth in the last sentence of paragraph 7.2.

1.32 Request for Information - A written communication from the Contractor to the Designer for any interpretation of, or information needed, required, or desired under the Contract Documents. The Owner reserves the right to determine the reasonable format and contents required for a Request for Information. In any Request for Information, the Contractor shall state a reasonable date by which a response is necessary in order to avoid delay in progress on the Work and shall make such request sufficiently in advance of such date as to avoid any such delay. The Designer shall respond in writing to the Request for Information by the date stated by the Contractor unless he cannot reasonably do so, in which case he shall prior to that date notify

the Contractor of the date by which he can reasonably respond. The Contractor shall not be entitled to any additional time for the completion of the Work or any portion thereof by reason of the Designer's failure to respond if he has not submitted his Request for Information sufficiently in advance to allow the Designer a reasonable time within which to respond.

1.33 Request for Payment - The form, in the form of AIA Document G702 (latest ed.) or other published document approved by Owner, which is to be used by the Contractor in requesting progress payments and which is to include a Schedule of Values as required by the Contract Documents and an affidavit of the Contractor that progress payments theretofore received from the Owner on account of the Work have been applied by the Contractor to discharge in full all the Contractor's obligations incurred in connection with Work covered by all prior applications for payment. See paragraph 20.2.

1.34 Resident Superintendent - That person designated by the Contractor in accordance with paragraph 7.2 who has day-to-day responsibility for the prosecution of the Work and the obtaining of proper materials and equipment, and adequate labor and who shall have the authority set forth in the last sentence of paragraph 7.2.

1.35 Schedule of Values - Any breakdown of the Contract Price which may be required by the Contract Documents, and designated as such. See paragraph 20.1.

1.36 Specifications - That portion of the Contract Documents consisting generally of the written requirements for materials, equipment, construction systems, standards, and workmanship for the Work and performance of related services.

1.37 Subcontractor - A person, firm, or corporation who has entered into a direct contract with the Contractor to perform any of the Work at the Project.

1.38 Submittal - Shop drawings, product data, samples, and other documents required by the Contract Documents to be submitted by the Contractor to the Designer.

1.39 Submittal Register - See paragraph 13.2 of these General Conditions.

1.40 Substantial Completion - The point at which the Work, and Work by other Contractors on or in connection with the Project, as determined by the Designer, is sufficiently complete in accordance with the Contract Documents that it can be beneficially occupied by the Owner, and the Work can be utilized by the Owner for its intended use, and all necessary permits and permissions for Beneficial Occupancy and utilization having been obtained by the Contractor. All operations and maintenance manuals, Owner training, and as-built drawings must be submitted prior to Substantial Completion being achieved.

1.41 Sub-subcontractor - A person or entity that has a direct or indirect contract with a Subcontractor to perform any of the Work at the Project.

1.42 Work - The construction and services required by the Contract Documents, including all labor, materials, equipment, and services provided or to be provided by the Contractor to fulfill the Contractor's obligations.

1.43 All references in the Contract Documents to the masculine shall be interpreted as including the feminine or neuter and all references in the Contract Documents to the singular or the plural shall be interpreted as including the other, as may be appropriate in the reasonable interpretation of the Contract Documents.

## **ARTICLE 2. CORRELATION, INTERPRETATION AND INTENT OF CONTRACT DOCUMENTS**

2.1 It is the intent of the Specifications and Drawings and other Contract Documents to describe a complete Project in accordance with the Contract Documents.

2.2 The Contract Documents are complementary; what is called for by one is as binding as if called for by all. If the Contractor finds a conflict, error or discrepancy in the Contract Documents, the Contractor shall notify the Designer in writing before proceeding with the Work affected thereby. In resolving such conflicts, errors and discrepancies, the Contract Documents shall be given preference in the following order: Construction Contract, Modifications, Addenda, General Conditions, Specifications, and Drawings. Figure dimensions on Drawings shall govern over scale dimensions, and detailed Drawings shall govern over general Drawings. Any Work that may reasonably be inferred from the Contract Documents as being required to produce the intended result shall be supplied whether or not it is specifically called for. Work, materials or equipment described in words which, so applied, have a well-known technical trade meaning shall be deemed to refer to such meaning and to incorporate any recognized standards which are a part of such meaning if not otherwise defined within the Contract Documents.

2.3 Miscellaneous items, accessories and work which are not specifically mentioned, but which are essential to produce a complete and properly operating installation, or useable structure or plant providing the indicated function shall be furnished and installed without change in the Contract Price. Such miscellaneous items and accessories shall be of the same quality standards, including material, style, finish, strength, class, weight and other applicable characteristics, as specified for the major component of which the miscellaneous item or accessory is an essential part, and shall be approved by the Designer before installation. This requirement is not intended to include major components not covered by or inferable from the Contract Documents.

2.4 The Work of all trades under the Contract Documents shall be coordinated by the Contractor in such a manner as to obtain the best workmanship possible for the entire Project and all components of the Work shall be installed or erected in accordance with the best practices of the particular trade.

2.5 The Contractor shall fully complete the Work and shall be responsible for all of the Work under the Contract Documents to which the Construction Contract applies. If the Contractor is prevented from doing so by any limitation of the Contract Documents, the Contractor shall immediately give notice thereof to the Designer and the Owner in writing.

2.6 Standard specifications or manufacturers' literature, when referenced, shall be of the latest revision or printing unless otherwise stated and is intended to establish the minimum requirements acceptable.

2.7 For those materials specified without the use of brand names, the Contractor shall submit within thirty (30) days after his receiving the Construction Contract for signatures, any product that meets the express requirements of the Specifications. Such Submittal shall include manufacturer's data, test reports, performance data and certifications, samples, erection details, and other applicable information as required to permit determination by the Designer whether such proposed products are suitable. The Designer shall be the sole judge as to the suitability of any proposed product. The burden of proof of quality rests with the Contractor.

2.8 The Contractor is required to examine and read the complete set of Contract Documents for information concerning the Work, because some of the Work for which the Contractor will be responsible may be indicated on or in documentation applying primarily to the Work of one or more other separate prime contractors. No allowance will be made for the Contractor's failure to become familiar with the complete set of project documents.

2.9 Contractor's requests for clarification or information shall clearly define the cause(s) of Contractor's request and, as appropriate, shall include Contractor's interpretation and Contractor's proposed solution.

### **ARTICLE 3. FAMILIARITY WITH WORK, CONDITIONS AND LAWS**

3.1 The Contractor has investigated prior to bidding and is satisfied with all conditions affecting the Work, including but not restricted to those bearing upon transportation, disposal, handling and storage of materials, availability of labor, water, electrical power, roads and uncertainties of weather, or similar physical conditions at the Project site, and the character of equipment and facilities needed prior to and during prosecution of the Work. The Contractor is satisfied as to the character, quality and quantity of surface and subsurface materials or obstacles to be encountered insofar as this information is reasonably ascertainable from inspection of the Project site, including all exploratory work done by the Owner, as well as from information presented by the Contract Documents, or any other information made available to the Contractor prior to receipt of bids. Any failure by the Contractor to become acquainted with the available information shall not relieve the Contractor from the responsibility for estimating properly the difficulty or cost of successfully performing the Work.

3.2 The Contractor shall be entitled to make all inferences from the Contract Documents that would reasonably be made by a contractor having knowledge and experience with similar work; however, the Contractor shall not be entitled to infer from the Contract Documents any fact or condition which would not be inferred by a contractor having knowledge and experience with similar work and the Contractor shall be required to obtain independently such other information as a knowledgeable and experienced contractor would prudently obtain in order to evaluate any such condition.

3.3 The Contractor specifically acknowledges familiarity with all Federal, State, and local laws, ordinances, rules, and regulations which may in any manner affect those engaged or employed in the Work, or the materials or equipment in or about the Work, or in any way affect the conduct of the Work and agrees that the Contractor and the Contractor's employees, subcontractors, and suppliers will, at all times, comply with same. If the Contractor shall discover any provisions in the Contract Documents which are contrary to or inconsistent with any such law, ordinance, rule, or regulation, the Contractor shall immediately give notice thereof to the Designer and the Owner in writing, identifying any items of Work affected, and the Contractor shall not proceed

until the Contractor has received written direction from the Designer with respect to these items. If the Contractor performs contrary to or inconsistently with any such law, ordinance, rule, or regulation without such written direction, the Contractor shall bear all costs which are a consequence of such performance.

3.4 At times selected by the Designer after execution by the Contractor of the Construction Agreement, a pre-construction conference shall be scheduled and conducted for the benefit of the Project.

## **ARTICLE 4. BONDS**

4.1 A performance bond in the full amount of the Contract Price shall be required of the Contractor to guarantee the faithful performance of the Work in compliance with the Contract Documents, in such form as may be required by law and approved by the Owner. The bond shall be dated the same date as the Construction Contract and must be accompanied by a current copy of the power of attorney for the attorney-in-fact executing such bond on behalf of a surety company licensed to do business in the state of North Carolina.

4.2 A payment bond in the full amount of the Contract Price shall be required of the Contractor to guarantee the payment of all labor and material costs or claims in connection with compliance with the Contract. The payment bond shall be in such form as may be required by law and approved by the Owner. Said bond shall be dated and executed in the same manner as the performance bond in paragraph 4.1.

## **ARTICLE 5. INSURANCE AND INDEMNITY**

### **5.1 CONTRACTOR PROVIDED INSURANCE**

The Contractor shall, without limiting its obligations or liabilities, procure, pay for and maintain such insurance as is required by law and as is required by this Agreement to protect the Contractor and the Owner from claims for damages for bodily injury, including death, and from claims for property damage which may arise from the Contractor's or its representatives', consultants', Subcontractors', agents', or employees' operations under this Agreement. Such insurance shall be of the kinds and have limits of liability and coverages not less than the minimum limits hereinafter specified or required by law, whichever is greater. The Owner makes no representation as to the adequacy or sufficiency of such coverages.

The following requirements shall in no way be construed to limit or eliminate the liability of the Contractor, which arises from performance of Work under the Agreement. The Contractor is strictly responsible for any losses, claims, and costs of any kind which exceed the Contractor's limits of liability, or which may be outside the coverage scope of the policies. The insurance specified shall be provided by an insurer approved by the Owner, authorized to do such business in the State of North Carolina, and on terms approved by the Owner. Insurance companies utilized shall have a minimum rating of A- and Class VII as evaluated by the most current A.M. Best Rating Guide. If the insurer has a Best Rating less than A- and Class VII, the Contractor must receive specific written approval from the Owner prior to proceeding with any Work under the Agreement.

All agents and brokers shall hold valid licenses from the State of North Carolina. Before commencing mobilization to the Project site and not later than 7 days after the receipt of the Construction Contract by the Contractor for signatures, the Contractor shall furnish to the Owner a certificate or certificates of insurance in a form satisfactory to the Owner. Upon request of the Owner, the Contractor shall provide the Owner with certified copies of the insurance policies required by this Article, including without limitation declaration pages, conditions, exclusions and endorsements, and confirmation that each policy premium has been paid for the required term of this Agreement. A copy of the umbrella policy shall be provided to the Orange County Risk Manager. Certificates shall be signed by a person authorized by that insurer to bind coverage on its behalf. All insurance policies shall provide, as evidenced by Certificates of Insurance, that the insurance shall not be canceled, reduced, restricted, or changed in any way without at least 30 days prior written notice to the Owner.

With regard to expiration, cancellation, reduction, restriction, or any other change, certificates shall state: "Should any of the following described policies be canceled before expiration date or be due to expire within 30 days, the insurer shall mail 30 days prior written notice to named certificate holder." In the event of any such cancellation, non-renewal, reduction, restriction, or change in any insurance, the Contractor is obligated to replace such insurance within 7 days without a gap in coverage and file accordingly such notice with the Owner, and other interested parties. Failing immediate receipt of evidence of such replacement of insurance the Owner reserves the right to procure such insurance as the Owner considers desirable and the Contractor shall pay or reimburse the cost of the premium in respect thereof. It is expressly provided, however, that any action or inaction on the part of the Owner in this respect shall in no way change or reduce the Contractor's responsibilities and liabilities under this Agreement. Self-funded, policy fronting, or other non-risk transfer insurance mechanisms are not acceptable without prior written approval of the Owner. Full disclosure of such a program must be made prior to commencing mobilization to the Project site. Failure to make a full disclosure constitutes a material breach of the Agreement, justifying termination for default.

The Contractor shall name the Owner, the Designer, the Designer's consultants, and the Construction Manager as additional insureds under all its insurance contracts (except workers' compensation) with respect to and including without limitation liability arising out of activities performed by or on behalf of the Contractor, products and completed operations of the Contractor, and automobiles owned, hired, leased, or borrowed by the Contractor. The coverage shall contain no special limitations on the scope of protection afforded to additional insureds.

For any claims related to this Project, the Contractor's insurance or self-insurance shall be primary and noncontributory with respect to the Owner's insurance. Any insurance or self-insurance maintained by the Owner shall be excess and noncontributory with respect to the Contractor's insurance. All policies of insurance shall contain a clause waiving rights of subrogation against the Owner, unless the Owner approves otherwise in writing. Limits of coverage are not to be amended by deductible clauses of any nature without the express written consent of the Owner.

The Contractor shall be solely responsible for any deductible assumptions that may exist in any insurance policies required under this Agreement. In addition, the Contractor shall be responsible and shall not be reimbursed for any losses arising from any risk or exposure not insured as required herein, or not covered as a result of a normal policy exclusion or that falls

within the self-insured retention, if Contractor self-insured. The Contractor's insurance shall apply separately to each insured against whom claim is made or suit is brought, except with respect to the limits of the insurer's liability. The claim provisions in the Contractor's insurance policies must specifically state the insurance company or Contractor's Third Party Administrator, if self-insured, has both the right and duty to adjust a claim and provide defense. The policies shall not contain any provision or definition which would serve to exclude or eliminate from coverage third party claims, including exclusions of claims for bodily or other injury to shareholders, partners, officers, directors, or employees of the insured, the premises owner, real estate manager, or the insured's Subcontractor, or any family relative of such persons.

If the policies contain any warranty stating that coverage is null and void (or words to that effect) if the Contractor does not comply with the most stringent regulations governing the Work, it shall be modified so that coverage shall be afforded in all cases except for the Contractor's willful or intentional noncompliance with applicable government regulations. Any failure by any person to comply with reporting or other provisions of the policy including breach of warranties, shall not affect coverage provided to the Owner and its representatives, officials, and employees. The insolvency or bankruptcy of the Insured or of the Insured's estate shall not relieve the insurance companies of their obligations under these policies. Any clauses to the contrary are unacceptable and must be stricken. Failure to comply with these requirements shall be a material breach of this Agreement justifying termination for default.

#### 5.1.1 Worker's Compensation and Employers' Liability Insurance

The Contractor and its Subcontractors shall procure and maintain Workers' Compensation Insurance in the amount and type required by the State of North Carolina and federal law for all employees employed under the Agreement who may come within the protection of Workers' Compensation Laws and covering all operations under the Agreement whether performed by the Contractor or by his Subcontractors. In jurisdictions not providing complete Workers' Compensation protection, the Contractor and his Subcontractors shall maintain employers' liability insurance in an amount, form, company, and agency satisfactory to the State of North Carolina and the Owner for the benefit of all employees not protected by Workers' Compensation Laws and covering all operations under the Agreement whether performed by the Contractor or by his Subcontractors.

The Contractor shall pay such assessments as will protect the Contractor and the Owner from claims under the Workers' Compensation Laws, workers' or workmen's compensation disability benefits, and other similar employee benefit acts. The current Experience Modification Factor shall be indicated on the Certificate of Insurance. Coverage under this section shall be as required by federal and state Workers' Compensation and Occupational Disease Statutes, and shall have minimum limits as follows:

Coverage A: Statutory, State of North Carolina  
 Employers' Liability: Each Accident \$1,000,000  
 Disease - Policy Limit \$1,000,000  
 Disease - Each Employee \$1,000,000

Such insurance shall include Voluntary Compensation coverage, a Waiver of Subrogation in favor of the Owner as well as other endorsements that may be required by applicable jurisdictions.

#### 5.1.2 Automobile Liability Insurance

The Contractor shall procure and maintain automobile insurance against liability for bodily injury and property damage as described below, that may arise with respect to the Work being performed under the Agreement, and as will provide protection from claims which may arise out of or result from the Contractor's performance of the Work and the Contractor's other obligations under the Agreement, whether such performance of the Work is by the Contractor, by any representative or Subcontractor, by anyone, both officially and personally, directly or indirectly employed by any of them, or by anyone for whose acts any of them may be liable.

This policy of insurance shall carry the following minimum Limit of Liability: Combined Single Limit \$1,000,000 per occurrence; Aggregate \$2,000,000.00.

The policy of insurance shall contain or be endorsed to include the following:

- a) owned, hired, and non-owned automobile liability.
- b) If the policy contains a warranty stating that coverage is null and void (or words to that effect) if the transporter does not comply with the most stringent regulations governing the Work, it shall be modified so that coverage shall be afforded in all cases except for the transporter's willful or intentional noncompliance with applicable government regulations.

Any failure by any party to comply with reporting or other provisions of the policy including breach of warranties, shall not affect coverage provided to the Owner and its representatives, officials, and employees. No subcontracting of waste hauling shall be permitted without prior, written approval of the Owner.

#### 5.1.3 General Liability

This policy must be written on an Occurrence basis, with the following minimum Limits of Liability:

General Aggregate per project \$2,000,000.00  
 Products/Completed Operations Aggregate \$2,000,000.00  
 Bodily Injury and Property Damage csl/each occurrence \$1,000,000.00  
 Personal Injury and Advertising Injury \$2,000,000.00

The policy of insurance shall contain or be endorsed to include the following:

- a) Blanket Contractual Liability covering Contractor's indemnification obligations under this Agreement, in accordance with ISO policy form CG 00 01. Modifications to the standard provision will not be acceptable if they serve to reduce coverage.
- b) Premises/Operations Liability.
- c) Explosion, collapse, and underground fault.
- d) Independent Contractors and Independent Subcontractors coverage.
- e) Broad Form Property Damage.
- f) Personal Injury
- g) Cross Liability/Severability of Interest clause.

- h) Employer's Stop-Gap Liability endorsement, if applicable.
- i) Amendment of the Pollution Exclusion Endorsement to allow coverage for bodily injury or property damage caused by heat, smoke, or fumes from a hostile fire.
- j) Designated General Aggregate Limit Endorsement if required by the Contract Documents.

Coverage shall remain continuously in effect and without interruption for at least 6 years from the date of the Notice of Award and shall include coverage for exposures arising from operations that have been completed. The Contractor shall furnish the Owner and each other additional insured listed in the Agreement to whom the Certificates have been issued, evidence satisfactory to the Owner of continuation of such insurance at the date of Preliminary Acceptance and each year thereafter.

#### 5.1.4 Pollution Legal Liability (PLL)

Pollution Legal Liability coverage will be provided as follows: \$1,000,000.00 per occurrence; Aggregate \$2,000,000.00.

#### 5.1.5 Umbrella Liability

The Contractor shall maintain an occurrence basis (as distinguished from a "claims made" basis) Umbrella Liability policy (true follow form) over the underlying General Liability, Automobile Liability, and Employer's Liability, with the following limits of liability: Each Occurrence \$3,000,000, Aggregate \$3,000,000.

On a fully insured basis such coverage will be subject to a deductible no greater than \$10,000 per occurrence where coverage is not provided by the underlying insurance, but is provided by the Umbrella Liability policy.

The Contractor may use any combination of primary and umbrella insurance policies to comply with the insurance requirements, provided the resulting insurance is equivalent to the insurance stated herein.

All Occupational Disease exclusions must be deleted. Any Pollution Exclusion must be amended to allow coverage for bodily injury or property damage caused by spill, upset, overturn, heat, smoke, or fumes from a hostile fire.

#### 5.1.6 Property Insurance

The Contractor shall purchase All Risk Property Insurance on a Completed Value Form in the names of the Owner, Contractor, Subcontractors, and sub-subcontractors as their interests may appear with limits as follows:

- a) Full insurance value of the Work, or
- b) Amount equal to the Contract Price for the Work, whichever is higher.

The Contractor is responsible for all physical damage to owned or rented machinery, tools, equipment, forms, and other items owned, rented or used by the Contractor or Subcontractor(s) in the performance of the Work including all of Owner's property in Contractor's care, custody,

or control, and all such property while it is in transit. The insurance coverage evidencing such shall include a waiver of subrogation in favor of the Owner.

#### 5.1.7 Valuable Papers and Records

The Contractor shall provide valuable papers and records insurance with coverage in an amount commensurate with project scope and set forth in the Supplementary General Conditions.

#### 5.1.8 Claims

The Contractor shall notify the Owner within 24 hours of any claims or alleged claims received by the Contractor covered by any of the policies of insurance required in this Agreement. The Contractor shall provide a written copy of the claim or alleged claim to the Owner within 3 days of the Contractor's receipt of the claim or alleged claim. If a claim is settled to the satisfaction of the claimant, the Contractor shall submit a copy of the claimant's release to the Owner. If a claim or alleged claim is rejected by the Contractor or its insurance company, the Contractor shall immediately report this fact to the Owner.

Should 30 days elapse after the claim or alleged claim has been received by the Contractor, and the Contractor is not able to report a settlement or rejection of the claim, it shall report to the Owner the steps being taken with respect to the claim. Without limiting the foregoing, the Contractor shall notify in writing the county risk manager of any paid or incurred claims which may impair annual aggregate or general liability.

#### 5.1.9 Deductibles and Self-insured Retentions

Any deductibles or self-insured retentions must be declared to and approved by the Owner. At the option of the Owner, either: a) the insurer shall reduce to a maximum of \$250,000 or eliminate such deductibles or self-insured retentions with respect to the Owner, or (b) the Contractor shall provide evidence of collateral provided to insurers or procure a bond guaranteeing payment of losses and related investigations, claim administration, and defense expenses within the deductible or self-insured retention amount. Any self-insured retention or deductible amount on the policy shall not reduce the amount of collectible limits or liability.

#### 5.1.10 Subcontractors

The Contractor shall include all Subcontractors as Insureds under its policies, or shall furnish separate certificates, policies, and endorsements for each Subcontractor the Contractor intends to use. If a Subcontractor does not take out insurance in his own name and the Contractor wishes to provide insurance protection for such Subcontractor and such Subcontractor's employees, the Contractor shall either (a) procure appropriate policies in the name of the Subcontractor, or (b) cause a rider or riders to be attached to the Contractor's policies which shall identify the Subcontractor thereby covered; provided, however, in the case of the latter option, such a rider need not be attached to the Contractor's workers' compensation policy if such policy by its terms is sufficiently broad to cover the employees of all Subcontractors performing Work under the Contract Documents. Except as otherwise approved by the Owner in writing, Limits of Liability and coverage scope must be at a minimum as stringent as required of the Contractor by the Contract Documents. All Work performed for the Contractor by any Subcontractor shall be pursuant to an appropriate agreement between the Contractor and the Subcontractor which shall contain provisions that waive all rights the contracting parties may have against one another for damages caused by fire or other perils covered by insurance as

provided herein. Insurance monies received from any loss shall be divided as the respective interest of the parties affected shall appear.

## 5.2 OWNER CONTROLLED PROJECT SPECIFIC INSURANCE

In the event the Owner elects to purchase project-specific insurance affording coverage to the Contractor and Subcontractors, the terms and conditions of such coverage shall be set forth in the Supplementary Conditions.

## 5.3 CONTRACTOR AS JOINT VENTURE

If the Contractor is completing this Project on a joint venture basis, both joint venture partners retain all liabilities assumed by this Agreement, individually and collectively. This may include, but is not limited to, all premiums due, deductibles/self-insured retentions, coinsurance provisions, claim provisions, insurance policy conditions, and indemnification provisions hereunder.

Evidence of a Blanket Joint Venture Endorsement must be obtained from the General Liability and Contractor's Pollution Legal Liability carriers of each joint venture partner for a period of 6 years after completion of the Project, substantially as follows: **With respect to "your work", and the "products-completed operations hazard", you are an insured for your liability arising out of the conduct of any partnership or joint venture of which you were a partner or member, even though this partnership or joint venture is not shown as a Named Insured in the Declarations. This coverage is excess over any available liability purchased specifically to insure the partnership or joint venture. This coverage will not inure to the benefit of any other party except you."**

## 5.4 INDEMNIFICATION

The Contractor, to the fullest extent not expressly prohibited by law, shall defend, indemnify, and save harmless the Owner, the Designer, the Construction Manager and their respective officials, officers, employees, and agents from and against any and all liabilities (foreseeable or unforeseeable), penalties, fines, liens, forfeitures, demands, claims, causes of actions, suits, judgments, and costs and expenses incidental thereto, (including, without limitation, amounts paid pursuant to investigations, defense or settlements, and reasonable attorneys' fees), which any or all of them may hereafter suffer, incur, be responsible for, or pay out as a result of but not limited to:

- a) bodily injury (including sickness, disease, or death) to any person including but not limited to, the Contractor's employees or its representatives while on the site of the Project; or
- b) actual or alleged damage (including loss of use) to any property (public or private, including the Project or other property on the Project site); or
- c) contamination of or adverse effects on the environment arising directly or indirectly out of or in connection with the performance of the Work, including but not limited to any hazardous or toxic waste, substance, or constituent of any substance subject to regulation under CERCLA, RCRA, TSCA, and other Federal and state authorities that is spilled, released, threatening to release, or disposed of or destroyed by the Contractor or its Subcontractors on or off the site of the Project or while in transport to or from the site; or

d) any violation or alleged violation of laws and regulations, arising out of or in any way connected with the Work, caused in whole or in part by the Contractor, any Subcontractor or supplier or any representatives of the Contractor. The Contractor shall not be required to indemnify the Owner against losses resulting from a breach of this Agreement by the Owner or its other agents and contractors, or resulting from negligence, misconduct or violation of laws on the part of the Owner or its other agents and contractors.

e) upon completion of the Work the Contractor shall execute an affidavit, indemnification, and release stating there are no unpaid debts for any work that has been done or materials that have been furnished to the Project prior to and as of the date of substantial completion and further stating that Contractor shall indemnify, save and protect Owner and Owner's lender, if any, harmless from and against any and all claims, liabilities, liens, losses, damages, causes of action, and expenses (including court costs and reasonable attorney's fees related thereto) arising out of, in connection with, or resulting from any such claims, liabilities, liens, losses, damages, causes of action, or expenses. Such affidavit, indemnification, and release shall be in a form and substance acceptable to Owner. By executing this Agreement Contractor acknowledges the receipt of adequate consideration in return for said release.

The Contractor further agrees to obtain, maintain, and pay for such liability insurance coverages and endorsements as will insure the provisions of this paragraph 5.4. Furthermore, the Contractor agrees to be liable for and to indemnify and reimburse the Owner for all legal fees and disbursements paid or incurred to enforce the provisions of this paragraph. The indemnification obligations under this paragraph shall not be limited in any way by the amount or type of damages, compensation or benefits payable under worker's compensation acts, disability benefit acts, other employment benefit acts, or the amount of insurance carried or recovered.

The Owner acknowledges that hazardous or toxic waste, material, chemicals, compounds or substances, or other environmental hazards, contamination or pollution, (referred to hereinafter as "environmental hazards") may be present at the Project site that were not created, generated, or released at the Project site by the Contractor or its Subcontractors, agents or employees, acting alone or in concert with others. Unless the remediation, abatement or handling of such environmental hazards is part of the scope of the Work under this Agreement, then upon the discovery of such environmental hazards, the Contractor shall immediately, and in no event more than three days later, give notice to the Owner of the environmental hazards before they are disturbed. The Owner and the Designer shall thereupon promptly investigate the environmental hazards, and make such changes in the Drawings and Specifications as they may find necessary to abate, remediate, isolate or handle the environmental hazards. Any increase or decrease in the Contract Price or the Contract Time resulting from such changes shall be adjusted in the manner provided herein for adjustments as to extra or additional Work and changes. It is agreed that the Contractor shall have no liability under this Agreement for any environmental hazards existing prior to the date that Work commences under this Agreement unless the Contractor or its Subcontractors, agents or employees, acting alone or in concert with others, by their own negligence or misconduct, release or expose the Owner or third parties to the environmental hazards. The provisions of this paragraph shall survive the termination or cancellation or completion of this Agreement.

## 5.5 RISK MANAGEMENT POLICY

The Orange County Risk Management Policy shall not apply to construction contracts for amounts over \$250,000. The terms of these General Conditions related to insurance shall be the sole authority governing insurance requirements for such contracts.

## **ARTICLE 6. OTHER RECORD DOCUMENTS AND SUBMITTALS**

6.1 The Designer shall furnish to the Contractor the number of copies of Drawings and Specifications stated in the Contract Documents. Additional copies of Drawings and Specifications may be obtained at the cost of reproduction and handling.

6.2 The Contractor shall submit to the Designer all Submittals required by the Contract Documents. The Contractor shall submit at least three (3) reproducible prints of all shop drawings. The Contractor shall submit samples in quantities required by the Contract Documents. The Contractor shall submit product data in at least five (5) copies. All shop drawings shall be reviewed by the Contractor and shall bear the Contractor's stamp of approval before being forwarded to the Designer. Submittals shall be submitted in such time as to cause no delay to the Work or any part thereof and in accordance with the Contract Construction Schedule and Submittal Register. The Designer shall review the submittal with reasonable promptness, noting desired corrections, if any. The Designer shall retain two (2) copies of the submittal and shall return the balance of the reviewed submittal to the Contractor for action. The Contractor shall furnish any corrected submittal to the Designer. The Designer shall retain two (2) copies of the corrected submittal and will return the balance of the reviewed submittal to the Contractor. All substitutions prior to the receipt of bids shall be in accordance with the Contract Documents. Refer to Instructions to Bidders, Substitutions.

The Contractor acknowledges that the processing of shop drawings and other submittals is directly impacted by the clarity, completeness, and accuracy of said documents and that it is the Contractor's responsibility to (i) review and coordinate each submittal with all other related or affected Work and (ii) approve each submittal before submitting same to the Designer for approval.

6.3 No substitutions and no deviations from any requirement of the Contract Documents shall be deemed allowed unless the Contractor has specifically informed the Designer and the Owner in writing of such deviations at the time of submittal and the Designer and the Owner have given written and specific approval to the substitutions or deviations. In proposing a deviation or substitution the Contractor warrants to the Owner, notwithstanding any review, allowance or approval by the Designer or the Owner that the deviation or substitution is at least equal to or better in quality and for the purpose intended, and that Contractor shall not by reason of any such review, allowance or approval be relieved from any obligation or responsibility contained in the Contract Documents.

6.4 Review of submittal by the Designer shall not be construed as relieving the Contractor from responsibility for compliance with terms or designs of the Contract Documents nor from responsibility for errors of any sort in the submittal.

6.5 The Contractor shall keep one record copy marked "As-Built" of all Specifications, Drawings, Addenda, Modifications, and Submittals at the Project in good order and annotated at least monthly to show all changes made during the construction process. Such monthly annotations

and their approval by the Designer shall be a condition precedent to approval by the Designer of each monthly Request for Payment. Said record copy shall be stored at the Project and fully protected from damage by fire or other hazard. This record copy shall be available to the Designer and Owner for inspection at all times and shall be delivered to the Designer for the Owner's purposes prior to the Designer's certifying Substantial Completion of the Work.

6.6 At completion of the Project and before Final Payment, the Contractor shall assemble and deliver to the Owner one complete set of all as-built drawings and one complete set of all approved submittals, product data, and samples which were reviewed by the Designer. These drawings and submittals shall be on paper, or in electronic or other media if required by the Supplementary Conditions. These drawings and submittals shall be categorized and packaged as directed by the Designer.

## **ARTICLE 7. CONTRACTOR**

7.1 The Contractor shall supervise and direct the Work efficiently and with the Contractor's best skill and attention. Except as may be set forth specifically in the Contract Documents, the Contractor shall be solely responsible for the means, methods, techniques, sequences, and procedures of construction, and for safety precautions and programs in connection with the Work. The Contractor shall be responsible to see that the finished Work complies accurately with the Contract Documents.

7.2 The Contractor shall appoint a Project Manager and shall keep on the Project at all times during its progress a competent Resident Superintendent and necessary assistants who shall not be replaced without prior written approval by the Owner except under extraordinary circumstances, in which event immediate written notice shall be given to the Designer and the Owner. The Project Manager and the Resident Superintendent may be the same person or different persons. At any time, the Owner, in its sole and absolute discretion, may require the Contractor to replace the Project Manager or Resident Superintendent with an experienced and competent person or persons upon seven (7) days written notice from the Owner to the Contractor. Such replacement shall be at the Contractor's expense and at no cost to the Owner. Both the Project Manager and the Resident Superintendent shall have authority to act on behalf of the Contractor, and instructions, directions or notices given to either of them shall be as binding as if given to the Contractor.

7.3 The Contractor shall provide sufficient competent and suitably qualified personnel, equipment, and supplies to lay out the Work and perform construction as required by the Contract Documents. The Contractor will at all times maintain good discipline and order at the site, and will comply with all applicable OSHA standards.

Any person employed by the Contractor, any Subcontractor, or any sub-subcontractor who, in the opinion of the Designer or the Owner, does not perform his Work in a proper and skillful manner or is intemperate or disorderly shall, at the written request of the Owner or Designer, be removed forthwith by the Contractor, Subcontractor, or sub-subcontractor employing such person without cost to the Owner, and shall not be employed again in any portion of the Work without the written approval of the Owner or Designer.

Should the Contractor fail to remove such person or persons or fail to furnish suitable and sufficient personnel for the proper prosecution of the Work within three (3) days after written

order, the Owner may withhold further payment by written notice until compliance with such order.

7.4 If, in the opinion of the Designer or the Owner, any Subcontractor on the Project is incompetent or otherwise unsatisfactory, he shall be replaced by the Contractor with no increase in the Contract Price if and when directed by the Designer or the Owner in writing.

7.5 The Contractor shall furnish all materials, equipment, labor, transportation, construction equipment and machinery, tools appliances, fuel, light, heat, and all other facilities and incidentals necessary for the execution, maintenance, initial operation, and completion of the Work, other than those specifically excluded by the Contract Documents and to be furnished by the Owner or others. When use or storage of hazardous materials or equipment or methods of more than ordinary risk are necessary in accomplishing the Work, the Contractor shall give the Owner and Designer reasonable advance notice.

If any materials are to be furnished or installed by the Owner or others under the terms of the Contract Documents, said materials shall be made available to the Contractor at the location(s) specified in the Contract Documents. All costs of handling, transportation from the specified location to the Project, storage, and installing of Owner-furnished materials shall be included in the Contract Price. The Contractor shall be responsible for any demurrage, damage, loss, or other deficiencies which may occur during the Contractor's handling, storage, or use of such Owner-furnished material. The Owner shall deduct from any monies due or to become due the Contractor any cost incurred by the Owner in making good any such damage, loss, or efficiency.

All equipment which is proposed to be used in the Work shall be of sufficient size and in such mechanical condition as to meet the requirements of the Work and produce a satisfactory quality of work. Equipment used on any portion of the Work shall be such that no injury to previously completed Work, adjacent property, or existing facilities shall result from its use.

When the methods and equipment to be used by the Contractor accomplishing the Work are not prescribed in the Contract Documents, the Contractor shall be free to use any methods or equipment that will accomplish the Work in conformity with the requirements of the Contract Documents.

When the Contract Documents specify the use of certain methods and equipment, such methods and equipment shall be used unless others are authorized by the Designer. If the Contractor desires to use a method or type of equipment other than specified in the Contract Documents, the Contractor may request authority from the Designer to do so. The request shall be in writing and shall include a full description of the methods and equipment proposed and of the reasons for desiring to make the change. If approval is given, it shall be on the condition that the Contractor shall be fully responsible for producing Work in conformity with the requirements of the Contract Documents. If, after trial use of the substituted methods or equipment, the Designer determines that the Work produced does not meet the requirements of the Contract Documents, the Contractor shall discontinue the use of the substitute method or equipment and shall complete the remaining Work with the specified methods and equipment at no additional cost to the Owner. The Contractor shall remove any deficient Work and replace it with Work of specified quality, or take such other corrective action as the Designer may direct. No change in the Contract Price or in Contract Time shall be made as a result of authorizing a change in methods or equipment under this paragraph.

7.6 All materials and equipment shall be new, except as otherwise provided in the Contract Documents. When special makes or grades of material which are normally packaged by the supplier or manufacturer are specified or approved, such materials shall be delivered to the Project site in their original packages or containers with seals unbroken and labels intact.

Materials shall be so stored as to assure the preservation of their quantity, quality and fitness for the Work. Stored materials, even though approved before storage, may again be inspected by the Designer or Owner prior to their use in the Work and shall meet the requirements of the Contract Documents at the time they are incorporated into the Work. Stored materials shall be located so as to facilitate their prompt inspection. The Contractor shall coordinate the storage of all materials with the Designer and the Owner. Materials to be stored at the Project or on the Owner's property shall not create an obstruction to the Owner's or other contractor's reasonable activities. Private property shall not be used for storage purposes without written permission of the owner or lessee of such property. The Contractor shall make all arrangements and bear all expenses for the storage of materials on private property. Upon request, the Contractor shall furnish the Owner a copy of the property owner's permission. All storage sites on private or the Owner's property shall be restored to their original condition by the Contractor at his entire expense, except as otherwise agreed to (in writing) by the owner or lessee of the property.

7.7 All materials and equipment shall be applied, installed, connected, erected, used, cleaned and conditioned in accordance with the instructions of the applicable manufacturer, fabricator, or processor, except as otherwise provided in the Contract Documents.

7.8 The Contractor will be fully responsible for all acts and omissions of his Subcontractors and of persons directly or indirectly employed by them and of persons for whose acts any of them may be liable to the same extent that the Contractor is responsible for the acts and omissions of the Contractor's own employees. Nothing in the Contract Documents shall create any contractual relationship between any Subcontractor or supplier and the Owner or the Designer, or any obligation on the part of the Owner or the Designer to pay or see to the payment of any money due any such Subcontractor or material furnisher except as may otherwise be required by law. The Owner or the Designer may furnish to any Subcontractor or supplier, to the extent practicable, evidence of amounts paid to the Contractor on account of specific Work done.

7.9 The divisions and sections of the Specifications and the identifications of any Drawings shall not control the Contractor in dividing the Work among Subcontractors.

7.10 The Contractor agrees to bind specifically every Subcontractor to the terms and conditions of the Contract Documents for the benefit of the Owner and to furnish written evidence thereof to the Designer and the Owner within seven (7) days after written request by the Owner.

7.11 The Contractor shall attend job progress conferences and all other meetings or conferences as directed by the Designer. The Contractor shall be represented at these job progress conferences by a representative having the authority of the Project Manager and by such other representatives as the Designer may direct. Job progress conferences shall be open to Subcontractors, suppliers and any others who may contribute beneficially toward maintaining required job progress, and such personnel shall be encouraged by the Contractor to attend. It shall be the principal purpose of job progress conferences to effect coordination, cooperation and assistance in every practical way toward the end of maintaining progress of the Project on

schedule and to complete the Work and the Project by the specified Completion Dates. The Contractor shall be prepared to assess progress of the Work as required in the Contract Documents and to recommend remedial measures for correction of progress as may be appropriate. The Designer shall preside as chairman and arrange for minutes to be taken and circulated.

In the event that the prosecution of the Work is discontinued for any reason, the Contractor shall notify the Designer and the Owner at least forty-eight (48) hours in advance of resuming operations.

Should the terms of the Contract Documents require completion of one or more portions of the Work for the Beneficial Occupancy of the Owner prior to completion of the entire Work, the Contractor shall complete such portion(s) of the Work on or before the date specified. Such completion shall include the obtaining of all government or other permits, permissions, and approvals necessary to occupancy. The Contractor shall independently estimate the difficulties involved in arranging the Work to permit such Beneficial Occupancy and shall not claim any additional compensation or time extension by reason of any delay or increased cost due to completing such portion(s) of the Work. The Owner's possession and use of such portion(s) of the Work shall not be deemed an acceptance of any Work not completed in accordance with the Contract Documents. The Owner shall be responsible for the security, maintenance, utilities, and insurance of all portions of the Work completed and beneficially occupied by the Owner.

7.12 The Contractor shall pay all license fees and royalties, and assume all costs incident to the use of any invention, design process, or device which is the subject of patent rights or copyrights held by others, except for inventions, design processes, or devices specified by the Designer in the Contract Documents. The Contractor shall indemnify and hold harmless the Owner, the Designer, and anyone directly employed by either of them, from and against all claims, damages, losses and expenses, including attorney's fees and costs of defense, arising out of any infringement or alleged infringement of such rights during or after completion of the Work, and shall defend all such claims in connection with any actual or alleged infringement of such rights.

7.13 The Contractor shall secure and pay for all permits, including without limitation construction permits and licenses, and will pay all governmental charges and inspection fees necessary for the prosecution of the Work.

7.14 The Contractor shall give all notices and comply with all laws, ordinances, rules, and regulations applicable to the Work and shall protect and indemnify the Owner and the Owner's officers, agents, or servants against any claim or liability arising from or based on the violation of any such law, ordinance, regulation, order, or decree, whether by the Contractor or by the Contractor's employees, Subcontractors, sub-subcontractors, or their employees.

7.15 The Contractor shall be responsible for the entire site of the Project (except those under the Beneficial Occupancy of the Owner) and for its reasonable and necessary protection and security, as required by laws or ordinances governing such conditions, or by custom or sound construction practices, and shall share such responsibilities as may be agreed upon among them, or in the absence of such agreement, as may be directed by the Contract Documents, Owner, or Designer. The Contractor shall be responsible for any damage to the Owner's property, or that of others, by the Contractor or the Contractor's employees, Subcontractors,

sub-subcontractors, or their employees or agents, and shall make good such damages. The Contractor shall be responsible for and pay for any such claims against the Owner.

7.16 The Contractor shall protect all landscaping designated to remain in the vicinity of the operations and barricade all walks, roads, and areas as necessary to keep the public away from the construction.

7.17 The Contractor shall provide cover and protect all portions of the Work and provide all materials necessary to protect the Work whether performed by the Contractor or any of the Subcontractors or sub-subcontractors. Any Work damaged through the lack of proper protection, or from any other cause, shall be repaired or replaced without extra cost to the Owner or extension to the Contract Time.

The Contractor shall maintain the Work during construction and until the Work is accepted. This maintenance shall constitute continuous and effective effort prosecuted day by day, with adequate equipment and forces so that the Work is maintained in satisfactory condition at all times. All costs of maintenance shall be included in the Contract Price and the Contractor will not be paid an additional amount for such effort. Should the Owner or Designer observe that the Contractor at any time has failed to maintain the Work as provided herein, the Designer may immediately notify the Contractor of such noncompliance. Such notification shall specify a reasonable time within which the Contractor shall be required to remedy such unsatisfactory maintenance condition. Should the Contractor fail to properly respond to the Designer's notification, the Owner may, at the Contractor's expense, take such action as it may deem appropriate to remedy the defective maintenance, including suspension of the Contractor's Work or any part thereof. Any such expense incurred by the Owner shall be deducted from monies due or to become due the Contractor.

Parking lots, streets, and walks connecting to the Project area shall be protected by the Contractor from deposits of mud, sand, stone, litter, or debris in any form. Pedestrian traffic areas around the construction limits must be maintained in a clean and safe condition at all times with required barricades and covered walkways. When excavation or other operations outside the Project limits is required, the Contractor shall, immediately following that work, return the area to its original condition.

All catch basins and storm drain lines in the vicinity of the Project site shall be protected at all times from entry of dirt, rubble and other debris. The residue from the cleaning of trucks, wheelbarrows, concrete buggies, etc. must be prevented from entering the drainage system, and if cleaning is done, the residue must be contained and removed from the Project site with other refuse.

7.18 No burning of refuse or debris shall be allowed inside or around the Project during the course of construction without written authority from authorities having jurisdiction and the Owner.

7.19 The Contractor shall provide for and maintain necessary safety measures and safety programs for the protection of all persons involved with the Work. Such measures and programs shall include the requirements of the most current edition of the CAGC Safety and Health Manual [or the AGC Accident Prevention Manual in Construction], or equivalent requirements, and shall fully comply with all Federal, State, and local laws, rules, regulations, and building

code requirements relating to the prevention of accidents or injuries to persons on or about the location of the Work.

All trenches, excavations, or other hazards in the vicinity of the Work shall be well barricaded, and properly lighted at night. When Work requires closing of an area normally used by the Owner or the public, the Contractor shall furnish, erect, and maintain temporary barricades, and properly light the area. The Contractor shall comply with any directions and public authorities in this respect.

7.20 The Contractor shall designate a responsible officer or employee as safety inspector, whose duties shall include accident prevention on the Project as well as implementation of the Contractor's safety measures and safety programs on the Project. The name of the safety inspector shall be made known to the Designer and the Owner at the preconstruction conference.

7.21 In emergencies affecting the safety of persons, the Work, or property at the Project site or adjacent thereto, the Contractor is obligated to act in the Contractor's discretion to prevent threatened damage, injury, or loss. As soon as practicable, the Contractor shall notify the Designer and Owner of such emergency. The Contractor shall give the Designer and the Owner prompt written notice of any significant changes in the Work or deviations from the Contract Documents caused by such emergency. If the Contractor believes that additional work done in an emergency entitles the Contractor to an increase in the Contract Price or an extension of the Contract Time, the Contractor may make a claim therefore as provided in Articles 14 or 15.

7.22 The Contractor shall at all times keep the premises free from accumulation of waste materials or rubbish caused by the Work. At least weekly and at the completion of the Work, the Contractor shall remove all waste materials and rubbish from and about the Project. At the completion of the Work, the Contractor shall remove all tools, construction equipment, machinery, and surplus materials. The Contractor shall leave the Work in condition for occupancy by the Owner such that no cleaning or other operations are required. Material cleared from the Project and deposited on adjacent property shall not be considered as having been disposed of satisfactorily. If the Contractor fails to keep the Project clean of waste materials or rubbish, fails to satisfactorily clean-up weekly or at the completion of the Work, the Owner may do so and the costs thereof may be deducted from any amounts due the Contractor.

7.23 Utilities, temporary facilities, and signs shall be provided as described in the Contract Documents. Absent a contrary direction in the Supplementary Conditions, the Contractor shall pay all bills for water, electricity, or other public utility service to the Project site.

7.24 The Contractor shall indemnify and hold the Owner, the Designer, the Designer's consultants, and their officers, agents, and employees harmless against all costs, damages, and expenses, including attorney's fees and costs of defense, arising out of claims by any separate contractor or by any Subcontractor, sub-subcontractor, or supplier engaged by or employed by the Contractor or employed by any of the Subcontractors claiming through him, including without limitation damages, losses, and expenses arising out of or relating to any inconvenience, delay, interference, or other action or non-action of the Contractor or the Contractor's Subcontractors on the Project.

The Contractor acknowledges that should the Contractor or any of the Contractor's Subcontractors be damaged by any breach of contract by any other separate prime contractor on the Project, the Contractor may invoke applicable dispute resolution procedures with said other separate prime contractor or bring a direct civil action against said other separate prime contractor. The Contractor hereby expressly agrees that neither the Owner nor its officers, agents, or employees shall have any liability of any kind or nature whatsoever to the Contractor, its Subcontractors, sub-subcontractors, or suppliers arising out of or relating to any breach, inconvenience, delay, interference, or other action or non-action by any other separate prime contractor. The Contractor covenants not to sue the Owner for any loss or damage caused by any breach, inconvenience, delay, interference, or other action or non-action by any other separate prime contractor, notwithstanding whatever rights at law the Contractor might have to bring a civil action against the Owner for any breach, inconvenience, delay, interference, or other action or non-action of any other separate prime contractor. The Contractor agrees to look exclusively to the other prime contractor for relief or remedy.

Nothing contained herein or appearing anywhere in the Contract Documents shall obligate or require the Owner to exercise any right or privilege, or to take any action or to refrain from taking any action under any contract it may have with any other prime contractor or party to the Project for the benefit of the Contractor or any Subcontractor, subSubcontractor, or supplier claiming through the Contractor.

7.25 Prior to completion of the Work and Final Payment of the Contract Price, excepting only those portions of the Work deemed accepted in accordance with the Contract Documents, the Contractor shall have charge and care of the Work, and shall take every precaution against injury or damage to any part due to the action of the elements or from any other cause, whether arising from the execution or from the non-execution of the Work. The Contractor shall as required by the Owner replace, rebuild, repair, restore, and make good all injury or damage to any portion of the Work occasioned by any of the above causes before Final Completion and shall bear the expenses thereof.

7.26 In the event that the Work, or any portion thereof, is suspended at any time pursuant to an order of the Owner, the Contractor shall obey all instructions of the Owner regarding storage of materials, drainage, protection of the Work, and erection of temporary structures during the suspension period.

7.27 The Project Expediter for the Project shall be responsible for the coordination of the Work of itself and any other separate contractors, both as to space and time. The Project Expediter shall coordinate the implementation of the Contract Construction Schedule, all construction activities and close-out of the Project, including but not limited to all testing, inspection, certifications, and approvals required by public agencies.

The Contractor and the Project Expediter shall each be required to notify the Designer and the Owner promptly of any event or condition which could affect the conduct or progress of the Work and shall cooperate fully with all other contractors on the Project site.

7.28 The Owner hereby delegates to the Project Expediter all of its duties to coordinate and to expedite the Work not expressly reserved to the Owner by other provisions of the Contract Documents.

7.29 All Work performed pursuant to the Contract Documents shall conform in all respects to the North Carolina State Building Code and all other state, local, and national codes in effect at the time of and applicable to this Work.

7.30 The Contractor shall provide for and maintain necessary safety measures and safety programs for the protection of all persons at the Project site, and shall comply at all times with the requirements of the most current edition of the CAGC Safety and Health Manual [or the AGC Accident Prevention Manual in Construction], or the equivalent requirements of the Contractor's safety program, and shall fully comply with all Federal, State, and local laws, rules, regulations, and building code requirements so as to prevent accidents or injuries to persons on or about the Project site. The Contractor shall clearly mark or post signs warning of existing hazards, and shall barricade excavations, elevator shafts, stairways, and similar hazards. The Contractor shall protect against damage or injury resulting from falling materials, and shall maintain all protective devices and signs throughout the progress of the Work.

7.31 The Contractor shall adhere to the rules, regulations, and interpretations of the North Carolina Department of Labor's Occupational Safety and Health Standards for the Construction Industry (29 CFR Part 1926 as adopted in 13 NCAC 07F.0201, including 29 CFR Part 1910 General Industry Safety and Health Standards applicable to construction) and N.C. Gen. Stat. §95-126 through 155 (Occupational Safety and Health) as well as all revisions and amendments to such standards or statutes as may occur throughout the performance of the Work.

7.32 Any land disturbing activity performed by the Contractor in connection with the Project shall comply with all erosion control measures set forth in the Contract Documents and any additional measures which may be required in order to ensure that the Project is in full compliance with the Sedimentation Pollution Control Act of 1973, as implemented by Title 15 North Carolina administrative Code, Chapter 4, Sedimentation Control, Subchapters 4A, 4B and 4C, as amended (15 NCAC 4A, 4B, and 4C), and as may be revised or amended in the future. Upon receipt of notice that a land-disturbing activity is in violation of said Act, the Contractor shall be responsible for ensuring that all steps or actions necessary to bring the Project in compliance with said Act are promptly taken. The Contractor shall be responsible for all penalties assessed pursuant to N.C. Gen. Stat. 113A-64 with respect to its Work, and shall indemnify and hold harmless the Owner from all costs and expenses, including attorney's fees and costs of defense arising out of or related to the enforcement of the Act against any party or person described in this Article.

7.33 Any mechanical or electrical work such as sleeves, inserts, chases, etc. located in the Work of the Contractor for general work shall be built in by that Contractor. On multiple prime projects, the mechanical and electrical contractors shall set all sleeves, inserts, and other devices built into the structure in cooperation and under the supervision of the Contractor for general work. The responsibility for exact location of such items shall be that of the mechanical, plumbing, or electrical prime contractor.

7.34 The Contractor shall be responsible for permanently fixed service facilities and systems in use during progress of the Work and shall strictly adhere to the following procedures:

a) Prior to acceptance of the Work by the Owner, the Contractor shall remove and replace any part of the permanent building systems damaged through use during construction.

b) Temporary filters shall be installed in each of the heating and air conditioning units, return air grilles, and other locations to prevent intrusion of dust, dirt, and debris during construction. Temporary filters shall be removed and replaced with new filters immediately prior to Substantial Completion.

c) Extra effort shall be maintained to keep the building clean and under no circumstances shall air systems be operated if finishing operations are creating dust in excess of what would be considered normal if the building were occupied.

d) When the permanent lighting system is used during construction, lamps shall be replaced and shall be new on the date of Substantial Completion.

## **ARTICLE 8. OWNER**

8.1 The Owner shall issue communications and notices to the Contractor through the Designer to the extent contemplated by the Contract Documents.

8.2 In case of termination of the employment of the Designer, the Owner shall appoint as Designer a qualified person who shall have and assume all rights and duties held by the original Designer.

8.3 The Owner shall have the right to take possession of and use any portion of the Work notwithstanding the fact that the time for completion of such portion of the Work may not have expired, but such taking possession and use shall not be deemed an acceptance of any Work not completed in accordance with the Contract Documents.

8.4 A waiver on the part of the Owner of any breach of any part of the Contractor shall not be held to be a waiver of any other or subsequent breach.

8.5 The Owner shall pay all permanent acreage fees, governmental impact fees, and meter deposits for permanent utilities.

## **ARTICLE 9. CONSTRUCTION MANAGER**

9.1 The Owner may employ one or more Construction Managers for the purpose of assisting the Owner, Designer, and Contractor in developing and administering budgets and cost controls, in evaluating constructability and value engineering proposals, in establishing and maintaining a critical path method (CPM) schedule, in coordinating or expediting the Work with other projects being constructed by the Owner or others adjacent or near the Work, or for such other purposes as the Owner may deem appropriate. From time to time the Owner may identify such Construction Managers(s) to the Contractor in writing identifying any tasks assigned to such Construction Managers(s).

## **ARTICLE 10. DESIGNER**

10.1 The Designer is charged with the responsibility of interpretation of the Contract Documents. The Designer's decisions relating to aesthetic matters shall be final.

10.2 All Work completed under the Contract Documents shall be subject to review by the Designer. No Work is to be covered without the Designer's review or prior authorization. Any Work so covered without the Designer's review or prior authorization shall be uncovered at the Contractor's expense. The Contractor shall notify the Designer in writing at least twenty-four (24) hours in advance of covering any Work.

10.3 The Designer shall not be responsible for the construction means, methods, techniques, sequences, procedures, or the safety precautions and programs incident thereto, and shall not be responsible for the Contractor's failure to perform the Work in accordance with the Contract Documents, but shall be entitled to enforce any requirements in the Contract Documents specifying particular means, methods, techniques, sequences, or procedures.

10.4 The Designer shall be an Owner's representative during the construction period. The duties, responsibilities and authority of the Designer as the Owner's representative during construction are as set forth in the Contract Documents.

## **ARTICLE 11. TESTING AND SURVEYING**

11.1 Laboratory and field tests to determine compliance of construction with the Contract Documents shall be made by the Owner or testing consultants employed by the Owner except those required elsewhere in the Contract Documents to be paid for by the Contractor. The costs and expenses of providing samples for and assistance in any testing shall be borne by the Contractor and are included in the Contract Price. Any Work in which untested materials are used without approval or written permission of the Designer shall be removed and replaced at the Contractor's expense. Work found to be unacceptable or unauthorized will not be paid for and, if directed by the Designer shall be removed and replaced at the Contractor's expense. Unless otherwise designated, tests in accordance with the cited standard methods of ASTM or other generally recognized or specifically authorized methods which are current on the date of advertisement for bids shall be made at the expense of the Owner; provided, however, in the event that after such testing any Work is found to be defective or does not meet the requirements of the Contract Documents, the costs of retesting such Work and the costs of inspection services shall be paid by the Contractor. Samples shall be taken by a testing laboratory employed by the Owner. All materials being used are subject to inspection, tests, or rejection at any time prior to or during incorporation into the Work. Copies of all Owner test reports will be furnished to the Contractor at his written request. Copies of Contractor test reports shall be furnished to the Designer upon written request.

11.2 The Owner shall have the right to deduct the costs of additional testing as described in paragraph 11.1 from any money due the Contractor; or if no money is due the Contractor, the Owner shall have the right to recover these costs from the Contractor, from its sureties, or from both.

11.3 All layouts and surveying shall be accomplished by properly qualified personnel duly licensed in the State of North Carolina.

## **ARTICLE 12. SEPARATE CONTRACTS**

12.1 It is expressly understood that the Owner may deploy the Owner's own employees or engage other separate prime contractors to perform Work as a part of the Project whose work

will be performed simultaneously and sequentially with the performance of the Work by the Contractor. It shall be necessary for the Contractor to coordinate construction activities with such other contractors, particularly with respect to access to work areas, storage of materials, and use of elevators and other common facilities. The Contractor shall diligently and in good faith cooperate with the Owner, the Designer, and all other contractors with respect to such matters and shall regularly and faithfully attend any and all meetings called by the Owner or the Designer with respect to such matters. Any disputes between the Contractor and any other separate prime contractor with respect to such matters shall be resolved in accordance with the claim and dispute resolution procedures in the Agreement.

## **ARTICLE 13. CONTRACT TIME**

13.1 Within fourteen (14) days after receipt of the Construction Contract by the Contractor for signatures, the Project Expediter shall prepare and submit to the Designer and Owner for review and approval a preliminary progress schedule for the Work pursuant to the requirements stated in the Contract Documents.

13.2 Within fourteen (14) days after initial receipt of the Construction Contract for signatures the Contractor shall submit to the Designer a Submittal Register listing all Submittals the Contractor is required to make or proposes to make under the Contract Documents, the dates on which the Contractor proposes to make such Submittals and the dates by which the Contractor reasonably requires a response from the Designer with respect to each Submittal. The dates submitted shall be incorporated into the Contract Construction Schedule as Completion Dates when they have been approved or modified by the Owner. The Designer shall not be required to review any Submittal from the Contractor until a Submittal Register acceptable to and approved by the Owner has been submitted by the Contractor.

13.3 Not later than thirty (30) days following execution and delivery of the Construction Agreement by Owner to Contractor, the Owner shall deliver to the Contractor a Notice to Proceed. The Notice to Proceed shall state a commencement date on which it is expected that the Contractor will begin the Work to be performed under the Agreement. The Contract Time shall be measured from said specified commencement date. The commencement date stated in the Notice to Proceed shall not be earlier than three (3) days after the Notice to Proceed is served on the Contractor.

If, other than by mutual agreement, said specified commencement date is more than thirty (30) days after the date of execution and delivery of the Agreement from Owner to Contractor and the Contractor believes said delay justifies an increase in Contract Price or an extension of Contract Time, the Contractor may make a claim therefore as provided in Article 14 or Article 15. No Work shall be done prior to the date specified in the Notice to Proceed. A final Contract Construction Schedule shall be submitted for approval by the Contractor, Designer, and Owner no later than fourteen (14) days after Notice to Proceed. No payments shall be due the Contractor until this schedule is approved by all parties.

13.4 The Contract Construction Schedule is a Contract Document. The Contractor represents that the Contract Construction Schedule has been reviewed in detail, that the Contractor participated in its preparation, that all of the activities which impact, limit, or otherwise affect the time of completion of the Work are shown in the Contract Construction Schedule and that all of the activities of others which impact, limit, or otherwise affect the start, duration, or completion of

the Contractor's activities are also shown. The Contractor further represents that the Contractor can and will complete each activity within the time shown for that activity. **Time is of the essence with respect to each such activity and Completion Date.**

13.5 If the Contractor submits a construction schedule, progress report, or any other document that indicates or otherwise expresses an intention to achieve completion of the Work prior to any Completion Date required by the Contract Documents or prior to expiration of the Contract Time, no liability of the Owner to the Contractor for any failure of the Contractor to so complete the Work shall be created or implied.

13.6 If the Contractor, for reasons beyond the Contractor's control, is delayed in beginning any activity, the Contractor shall, nevertheless, have the same number of days as is shown in the Contract Construction Schedule for the activity, and the affected activity and any succeeding activity that is dependent upon that activity shall be adjusted accordingly; provided that at any time the Owner, by means of a Change Order, may require the Contractor to work overtime, to increase labor forces or to take any necessary or appropriate action to decrease the time required for any activity, and the Contractor shall be entitled to an adjustment in the Contract Price computed in accordance with Article 15 of these General Conditions.

13.7 At any time, the Owner may order the Contractor, on seven (7) days written notice, to begin any activity earlier than the starting date shown on the Contract Construction Schedule.

13.8 Should the Contractor fail to start any activity on the start date shown in the Contract Construction Schedule or as it may have been adjusted in accordance with paragraphs 13.5 or 13.6 above, or become delayed, the Contractor shall, without being entitled to any increase in the Contract Price or other compensation, work overtime, increase labor forces or take such other action as may be necessary or appropriate to complete the activity by the Completion Date shown on the Contract Construction Schedule, or as such Completion Date may have been adjusted.

13.9 The Designer and Owner or his Construction Consultant shall monitor progress of the work at all times and the Contractor shall cooperate with such monitoring and provide any and all information with respect to the progress of the Work and scheduling as the Owner may reasonably require.

13.10 On a monthly basis, the Contractor shall revise the Contract Construction Schedule, showing any adjustments made in accordance with paragraphs 13.5 or 13.6, above, by any Change Order, the progress of the Work, and any days gained or days lost with respect to any activity, and shall furnish copies thereof to the Owner and Designer.

13.11 Should any monthly revision of any Contract Construction Schedule show that the Contractor is behind on any activity, the late completion of which could delay Substantial Completion of the Work, the Owner shall be entitled to withhold from the next Progress Payment due the Contractor an amount not exceeding the amount the Owner would be entitled to in Liquidated Damages, should Substantial Completion be delayed by the same number of days that the Contractor is currently behind schedule. If, subsequently, the Contractor's progress, as shown by any succeeding monthly revision to the Contract Construction Schedule, is such that the anticipated delay no longer exists, the Owner shall pay with the Progress Payment next due to the Contractor such amounts as have been withheld in accordance with this paragraph.

13.12 The Owner shall have the right to perform Work, hire and employ labor and craftsmen, rent equipment, subcontract with other parties, or do anything that the Owner deems necessary or appropriate to remedy or cure any delay by the Contractor in the progress of the Work. Such action by the Owner shall not, in any way, affect, void or limit any warranty, guaranty or other responsibility of the Contractor under the Contract Documents. Such action may be taken by the Owner only after three (3) days written notice to the Contractor. All costs incurred by the Owner in taking any such action shall be charged to the Contractor and deducted from any amounts remaining due under the Agreement.

13.13 The Contractor may be entitled to an extension of the Contract Time (but no increase in the Contract Sum) for delays arising from unforeseen causes beyond the control and without the fault or negligence of the Owner, the Contractor or the Contractor's Subcontractors as follows:

- a) Labor disputes and strikes that directly impact the critical path activities of the Contract Construction Schedule;
- b) Acts of God, tornado, fire, hurricane, blizzard, earthquake, typhoon, or flood that damage completed Work or stored materials.
- c) Acts of the public enemy; acts of the State, Federal, or local government in their sovereign capacities.
- d) Abnormal inclement weather as defined in Article 13.14.

13.14 On any day that the Contractor considers that the Project is delayed by adverse weather conditions, the Contractor shall identify in writing to the Designer and the Owner the adverse weather conditions affecting each activity, the specific nature of the activity affected, the number of hours lost, and the number of and identity (by responsibility or trade) of workers affected and shall obtain from the Designer written recognition of the delay. The time for performance of this Contract includes an allowance for a number of calendar days which may not be suitable for construction Work by reason of adverse weather. The Contract Time will be extended only if the number of calendar days of adverse weather recognized by the Designer exceeds the number of inclement weather days set forth below, and the Contractor demonstrates how this adverse weather impacts activities on the critical path of the Contract Construction Schedule. Month

Number of Inclement Weather Days	
January	10
February	10
March	10
April	9
May	10
June	9
July	11
August	10
September	8
October	7
November	8
December	9

13.15 If the Contractor believes that the progress of the Work has been adversely affected by adverse weather recognized by the Designer during a particular month, the Contractor shall submit a written request for extension of time to the Designer. Such a request for time extension of the Contract Time shall be submitted by the tenth (10th) day of the month following that month in which the adverse weather is encountered. The request shall include, but is not limited to, the following information: a) Detailed description of weather's effect on scheduled activities and its net effect on the critical path of the Project, and b) Weather records from the official weather station nearest the Project site and records of actual observation as contained in daily reports, correspondence, or other documentation.

13.16 The Contractor specifically recognizes that a delay by the Contractor in achieving any Completion Date can have the effect of delaying the Substantial Completion of the Project, that such delay in Substantial Completion of the Project will necessarily cause damages, losses, and expenses to the Owner, including, but not limited to and by way of illustration only, increased capitalized costs and interests for the Project, increased and extended Project overhead, Designer's and Consultant's fees, increased costs of construction, increased and extended operation costs of other facilities, and inefficiency and loss of productivity, and that such damages, losses, and expenses may not be readily identifiable or ascertainable at the time they are incurred or at any time. Therefore, and in recognition of these factors and the likelihood that actual damages from his delay will not be readily ascertainable, the Contractor agrees to pay to the Owner, as Liquidated Damages and not as a penalty, the sum identified in the Contract Documents hereto as the Liquidated Damages per Day, for each day by which the failure to meet any Completion Date shown in the Contract Construction Schedule, adjusted in accordance with this Article, delays the Substantial Completion of the Project.

13.17 The Contractor shall not be entitled to any adjustment in the Contract Price or other compensation from the Owner for any delay in the completion of or progress on the Work that is caused by a force majeure condition or is otherwise not caused by the sole and direct act or omission of the Owner and the Owner's employees or agents.

13.18 The sum for Liquidated Damages is the amount stated in the Contract Documents as Liquidated Damages reasonably estimated in advance to cover the losses to be incurred by the Owner by reason of failure of said Contractor(s) to complete the Work within the time specified, such time being in the essence of this contract and a material consideration thereof.

#### **ARTICLE 14. CHANGES IN THE WORK**

14.1 Without invalidating the Contract Documents, the Owner may, at any time, or from time to time order additions, deletions, or revisions in the Work. Said additions, deletions, or revisions shall be authorized only by written Change Orders, Construction Change Directives or Field Orders. Upon receipt of a Change Order, Construction Change Directive or Field Order, the Contractor shall proceed with the Work involved. All such Work shall be executed under the applicable conditions of the Contract Documents. If any change causes an increase or decrease in the Contract Price or an extension or shortening of the Contract Time, adjustments shall be made as provided in Article 14 or Article 15. In order to expedite the Work and avoid or minimize delay in the Work that might affect the Contract Price or Contract Time, the Designer may issue a Change Order in the form of a Construction Change Directive which when signed by the Owner and Designer, directs the Contractor to proceed promptly with the Work involved. Any claim for an adjustment in Contract Price or Time, if not defined in the Construction Change

Directive, shall be promptly made in writing in accordance with the procedures defined in Article 15.2.

14.2 The Designer may authorize minor changes or alterations in the Work not involving change in the Contract Price or in the Contract Time and not inconsistent with the overall intent of the Contract Documents. These may be accomplished by a Field Order. Such alterations shall not invalidate the Contract Documents nor release the surety. If the Contractor believes that any minor change or alteration authorized by the Designer entitles him to an increase in the Contract Price or an extension of Contract Time, he may make a claim therefore as provided in Article 14 or Article 15.

14.3 Except in an emergency endangering life or property, no change shall be made by the Contractor except upon prior written Change Order, Directive or Field Order authorizing such Change.

14.4 Increases in the Contract Price or extensions of the Contract Time for additional Work performed by the Contractor shall only be in accordance with a written Change Order signed by the Owner and Designer. The Contractor shall not be entitled to additional time or to additional compensation for any Work performed or material supplied which is claimed to have been authorized or settled by an "oral" change, or by a "constructive" or "implied" change, or by a course of conduct, or by any action or non-action by the Owner, Designer, or any other persons, or by any means whatsoever other than by a written Change Order for such Work or material signed by the Owner and the Designer.

14.5 Changes in the Work resulting from emergency shall not invalidate the Contract Documents nor release the surety.

14.6 Neither the Owner nor the Designer shall be responsible for verbal instructions which have not been confirmed in writing, and in no case shall such instructions be interpreted as permitting a departure from the Contract Documents unless such instruction is confirmed in writing and supported by a proper Change Order, Construction Change Directive or Field Order, whether or not the cost is affected.

14.7 The Owner, in its sole discretion, may require that the Contractor notify the Contractor's sureties of any changes affecting the general scope of the Work or change in the Contract Price, and that the amount of applicable bonds shall be adjusted accordingly. If this requirement is exercised, the Contractor shall furnish proof of such adjustment to the Designer and the Owner.

If this requirement is exercised, the Change Orders shall require written consent of the Contractor's surety. At the time of signing a Change Order, the Contractor shall be required to certify as follows: "I certify that all sureties have been notified that my contract has been altered by the amount of this Change Order, and that a copy of the approved Change Order will be mailed to all sureties upon its receipt by me." If this requirement is exercised, no payment to the Contractor on account of any Change Order shall become due or payable until written evidence of the surety's consent to the Change Order has been furnished to the Designer and to the Owner, and the furnishing of such written consent is a condition precedent to such payment.

14.8 The Contractor shall support all requests for Change Orders with a detailed cost breakdown showing cost of materials, labor, equipment, transportation, other items, Contractor's overhead and profit, and total cost, in accordance with methods defined in this Article, and, if the request seeks an extension of the Contract Time, with a time-related diagram which demonstrates specifically why an increase in construction time is needed.

14.9 When a request for a Change Order involves a Subcontractor, the Contractor shall provide quotation from same on Subcontractor's letterhead. The Subcontractor's quote shall list materials, equipment, and labor separately, and show overhead and profit in the manner provided in paragraph 14.8.

## **ARTICLE 15. CHANGE OF THE CONTRACT PRICE**

15.1 The Contract Price constitutes the total compensation payable to the Contractor for performing all Work under the Contract Documents. All duties, responsibilities, and obligations assigned to or undertaken by the Contractor shall be at his expense without change in the Contract Price. The Contract Price may only be changed by a Change Order.

15.2 Any claim for an adjustment in the Contract Price shall be in writing and written notice of any event, action, or non-action which may become the basis of a claim shall be delivered to the Owner and the Designer within three (3) days of the occurrence of any such event, action or non-action giving rise to the claim. Such written notice is a condition precedent to the making of a claim, and such notice shall describe the basis of the potential claim with reasonable detail and clarity.

A claim shall be made in writing and shall be delivered to the Designer and the Owner no later than fourteen (14) days after such notice. The claim shall describe in detail the basis for the claim, with specific reference to any provisions of the Contract Documents, by paragraph, drawing number, or other specific identification, and shall state the amount claimed and how it is calculated. If the Contractor, at the time the claim is made, is unable to state the amount claimed with accuracy, the Contractor shall so state and provide the estimated amount and the basis on which the amount is to be calculated. At the earliest date practicable, but in no event more than thirty (30) days after Contractor's notice of claim, the Contractor shall supplement the claim with an accurate statement of the amount claimed and how it has been calculated. The Contractor shall provide, in writing, in support of the claim all such explanations, arguments, data, receipts, expert opinions, or other documents or information as the Contractor deems appropriate to be considered in support of the claim.

A claim may properly be rejected by the Owner by reason of the Contractor's failure to submit adequate or accurate documentation or information, except that within seven (7) days after being given notice that the claim has been rejected on this basis, the Contractor may submit additional documentation or information. No claim for a change of the Contract Price shall be considered or granted (except solely at the discretion of the Owner) unless a claim is so made, nor shall the Contractor be entitled to any increase in the Contract Price unless the Contractor has given notice and made such a written claim within the times required. The Owner shall decide, after obtaining the advice of the Designer, whether an increase in Contract Price is warranted, and the amount of such increase shall be determined as provided in paragraph 15.4 through 15.5, below. Any change in the Contract Price resulting from any such claim shall be incorporated in a Change Order.

The Owner shall advise the Contractor of its decision with respect to the claim within fourteen (14) days of its receipt, or of the receipt of additional documentation or information if the absence of such has previously been the basis of rejection of the claim; provided, however, that if, in its sole discretion, the Owner deems that review or consideration of any part of the claim or any matter related thereto by its governing Board is necessary or appropriate, it shall so advise the Contractor and shall provide its decision to the Contractor within seven (7) days after such Board consideration, review or action. Any claim on which the Owner has not provided its decision to the Contractor within the applicable time period shall be deemed denied. If the Contractor is not satisfied with the decision of the Owner, the Contractor may within seven (7) days of receipt of the Owner's decision initiate the mediation process as described in Appendix A to the General Conditions of the Contract for Construction.

15.3 In determining the amount of a Contract Price adjustment, the parties shall apply the following methods, as appropriate:

(A) Change in Work: The Owner and Contractor shall negotiate in good faith and attempt to agree upon the value of any change (extra or decrease) in Work prior to the issuance of a Change Order covering said Work. Such Change Order shall set forth the corresponding adjustment to the Contract Price. In the event the Owner and the Contractor are unable to agree, the Owner shall grant an equitable adjustment in the Contract Price.

(B) Emergency Work: In the event of emergency endangering life or property, the Contractor may be directed by the Designer to proceed on a time and material basis, whereupon the Contractor shall so proceed and keep accurately, in such form as may be required by the Designer, a correct account of costs together with all proper invoices, payrolls, and supporting data therefore.

15.4 Where the Contract Price is to be adjusted, the following limitations shall apply in determining the amount of adjustment:

(A) In the case of extra or emergency work, the Contract Price shall not be increased by more than the reasonable, actual, and documented net cost of the extra or emergency work plus ten percent (10%) of such net cost on Work performed by the Contractor and five percent (5%) thereof on any subcontracted Work for overhead and profit combined.

(B) In the case of a decrease in Work, the Contract Price shall not be decreased by less than the net cost of the deleted Work plus five percent (5%) of such direct net cost for profit and overhead.

The term 'net cost' as used herein shall include, as applicable, and shall be limited to, all direct labor, direct material, direct equipment, labor burden, sales taxes, shipping and handling charges, permits and fees, and insurance and bond premium adjustments, if any, attributable to the change. All other items of cost shall be considered as overhead and covered by the percentages allowed in sections A and B of this paragraph.

The Contractor shall provide worksheets or tabulations describing the method by which the direct net cost was calculated, and shall provide all data needed to support the calculation of the direct net cost, all in a form acceptable to the Owner.

15.5 Where the Contract Price is to be adjusted by negotiation, the Owner may authorize and designate the Designer to negotiate with the Contractor on behalf of the Owner; provided, however, any agreement reached between the Contractor and Designer shall be subject to approval by the Owner.

## **ARTICLE 16. UNFORESEEN CONDITIONS**

16.1 Should the Contractor encounter unforeseen conditions at the Project site materially differing from those shown on the Drawings or indicated in the Specifications or differing materially from those ordinarily encountered and generally recognized as inherent in work of the character provided for in this Agreement, the Contractor shall immediately, and in no event more than three days later, give notice to the Owner of such conditions before they are disturbed. The Owner and the Designer shall thereupon promptly investigate the conditions and if they find that they materially differ from those shown on the Drawings or indicated in the Specifications, they shall at once make such changes in the Drawings and Specifications as they may find necessary. Any increase or decrease in the Contract Price resulting from such changes shall be adjusted in the manner provided herein for adjustments as to extra or additional Work and changes. However, neither the Owner nor the Designer shall be liable or responsible for additional work, costs, or changes to the Work that could have been reasonably determined from any reports, surveys, and analyses made available for the Contractor's review or that could have been discovered by the Contractor through the performance of its obligations pursuant to the Contract Documents.

## **ARTICLE 17. CORRECTION OF WORK BEFORE FINAL PAYMENT**

17.1 The Owner has the authority to stop or suspend work, and the Designer has the authority to order Work removed or to order corrections of defective Work or Work not in compliance with the Contract Documents where such action may be necessary to ensure successful completion of the Work.

Any work, materials, fabricated items, or other parts of the Work which have been found by the Designer to be defective or not in accordance with the Contract Documents shall be condemned and shall be removed from the Project by the Contractor, and immediately replaced by new Work in accordance with the Contract Documents at no additional cost to the Owner. Work or property of the Owner or others damaged or destroyed by virtue of such condemned Work shall be made good at the expense of the Contractor. Correction of condemned Work described above shall be commenced by the Contractor within twenty-four (24) hours after notice from the Designer or the Owner and shall be pursued to completion. Should the Contractor fail to proceed reasonably with the abovementioned corrections, the Owner may, three (3) days after the notice specified in the preceding sentence, proceed with correction, paying the cost, including costs of uncovering such condemned Work, of such corrections from amounts due or to become due to the Contractor.

Condemned Work removed shall be the property of the Contractor and shall be removed from the Project by him within ten (10) days after notice to remove it, and if not then removed, thereafter may be disposed of by the Owner without compensation to the Contractor and the cost of such disposal shall be deducted from amounts due or to become due to the Contractor.

Should the cost of correction of the Work and, if applicable, disposal of the condemned Work by the Owner exceed amounts due or to become due the Contractor, then the Contractor and the Contractor's sureties shall be liable for and shall pay to the Owner the amount of such excess.

**ARTICLE 18. CORRECTION OF WORK AFTER SUBSTANTIAL COMPLETION;  
WARRANTIES AND GUARANTIES**

18.1 Neither the final certificate, Final Payment, occupation of the premises by the Owner, nor any provision of the Contract Documents, nor any other act or instrument of the Owner or the Designer shall relieve the Contractor from responsibility for negligence, defective material or workmanship, or failure to comply with the Contract Documents.

18.2 The Contractor shall, at the Contractor's sole cost and expense, make all necessary repairs, replacements, and corrections of any nature or description, interior or exterior, structural or non-structural, that shall become necessary by reason of defective workmanship or materials which appear within a period of one (1) year from the date of Substantial Completion; provided, however that notwithstanding the preceding, if any longer guarantee period is specified for any particular materials or workmanship under the Contract Documents, or under any subcontract, or in connection with any manufactured unit which is installed in the Project, or under the laws of the State of North Carolina, the longer guarantee period shall govern.

18.3 If, within any guarantee period, repairs or changes are required in connection with the Work, which are rendered necessary as the result of the use of materials, equipment, or workmanship which are inferior, defective, or not in accordance with the terms of the Contract Documents, the Contractor shall, promptly upon receipt of notice from the Designer and without expense to the Owner:

- a) Completely repair or replace the Work so that it conforms to the Contract Documents;
- b) Correct all defects therein;
- c) Make good all damage which, in the opinion of the Designer, is the result of the use of materials, equipment, or workmanship which are inferior, defective, or not in accordance with the terms of the Contract Documents; and
- d) Make good any Work or material, or any equipment or contents disturbed in fulfilling any such guarantee.

If, in fulfilling the requirements of the Contract Documents or of any guarantee embraced therein or required thereby, the Contractor disturbs any work, facility, premises, or construction belonging to the Owner, the Contractor shall restore such disturbed work to a condition satisfactory to the Owner, and shall guarantee such restored work to the same extent as if it were Work under the Contract Documents.

If the Contractor, after notice, fails to proceed promptly to comply with the terms of the guarantee, the Owner may have the defects corrected, and the Contractor and the Contractor's sureties shall be liable for all expenses incurred. "Promptly" is defined as within twenty-four (24)

hours for systems necessary to normal operation of the building and within seventy-two (72) hours for all other items. All special guarantees applicable to definite parts of the Work that may be shown in or required by Contract Documents shall be subject to the terms of this paragraph during the first year of the life of such special guarantee. Manufacturer's standard guarantees or warranties which do not comply with the time limit specified herein shall be extended by the Contractor automatically without further action on the part of the Owner or the Designer.

18.4 In the eleventh calendar month after the date of Substantial Completion, and at the request of the Owner, the Contractor, the Owner and the Designer shall make an inspection of the Work for the purpose of identifying defective workmanship or materials. If the Contractor, having been requested to do so by the Owner, fails to participate in such inspection, the Contractor shall be conclusively bound by any decision or ruling by the Designer as to any defective workmanship or material and as to the Contractor's responsibility for its repair or replacement.

#### **ARTICLE 19. OWNER'S RIGHT TO DO WORK**

19.1 If, during the progress of the Work or during any period of guarantee, the Contractor fails to prosecute the Work properly or to perform any provision of the Contract Documents, the Owner, after three (3) days written notice to the Contractor from the Designer, or from the Owner after Final Payment, may perform or have performed that portion of the Work and may deduct the cost thereof from any amounts due or to become due the Contractor. Notwithstanding any action by the Owner under this paragraph, all warranties and bonds given or to be given by the Contractor shall remain in effect or shall be given by the Contractor.

19.2 Should the cost of such action by the Owner exceed the amount due or to become due the Contractor, the Contractor and his sureties shall be liable for and shall pay to the Owner the amount of such excess.

#### **ARTICLE 20. PARTIAL PAYMENTS**

20.1 Within thirty (30) days after his initial receipt of the Construction Contract for signatures, the Contractor shall submit to the Designer a Schedule of Values. The Schedule of Values shall indicate the value of the Work, including applicable overhead and profit, for each Division and section of the Project Specifications. The Designer and Owner shall be provided with the Contractor's estimate papers, Subcontractor agreements, supplier quotes, or other documents substantiating these values if so requested in writing by the Designer. The Contractor shall provide the requested documentation within seven (7) days after receipt of the Designer's written request. The Schedule of Values shall be subject to approval by the Owner, and if the Owner and the Contractor cannot agree upon the Schedule of Values, the Designer shall prepare it, and the Schedule of Values as prepared by the Designer shall be binding on the Owner and the Contractor. No Request for Payment shall be certified by the Designer until the Designer has issued approval of said Schedule of Values.

20.2 Not later than the fifth (5th) day of each calendar month the Contractor shall submit to the Designer a Request for Payment for Work done during the previous calendar month. The Request for Payment shall be in form of AIA Document G702 (latest edition) and shall show substantially the value of Work done (including the value of material delivered to the Project or stored by the Contractor at another site, subject to the conditions hereinafter set forth) during

the previous calendar month, and shall sum up the financial status of the Work with the following information:

- a) Total Contract Price, including any adjustment thereto made pursuant to the Contract Documents.
- b) Value of Work completed and materials properly stored to date.
- c) Less amount retained.
- d) Less previous payments.
- e) Current amount due.
- f) Balance remaining.

The Contractor, upon request of the Designer, shall substantiate the request with invoices, vouchers, payrolls, or other evidence.

20.3 When payment is requested or made on an account of stored materials, such materials must be stored on the Owner's property at such places and in such a manner as may be designated by the Designer. However, in the sole discretion of the Owner, with permission in writing from the Designer and Owner and under such circumstances as may be determined by the Owner, such materials may be stored in a bonded warehouse. The location and conditions for storage of such materials away from the Owner's property in a bonded warehouse shall be within the sole discretion of the Owner. Requests for Payment on account of stored materials shall be accompanied by paid invoices, bills of sale, warehouse receipts, or other documentary evidence establishing Owner's title to such materials, evidence that the stored materials are insured against loss and damage, and such other documentation as required by the Designer. Responsibility for the quantity, quality, and condition of such stored materials, whether stored on the Owner's property or away from the Owner's property, shall remain with the Contractor regardless of ownership or title. No payment shall be made on account of materials stored in a bonded warehouse unless the Contractor has acquired written permission from the Designer for such storage of materials and has complied with all conditions set forth in such permission regarding such storage of materials in a bonded warehouse.

20.4 Any Request for Payment received by the Designer on or before the fifth (5th) of the calendar month shall be certified for payment or returned for re-submission to the Contractor on or before the fifteenth (15th) of the calendar month. The Designer's certification shall be for the amount which was requested or that which the Designer has decided was justly due, and shall state in writing to the Contractor and Owner the reasons for withholding payment of any or all of the amount requested.

20.5 The Designer may fail to certify all or part of any payment requested for any of the following reasons:

- a) Defective Work not corrected.

- b) Suits, actions, or claims of any character filed against the Contractor, or due to the operations of the Contractor, or information or notice that a suit, action, or claim will be filed or has been made.
- c) Information or notice that a Subcontractor or a supplier has not received payment.
- d) The balance unpaid of the Contract Price is insufficient to complete the Work in the judgment of the Designer or Owner.
- e) Damage to the Owner or another contractor.
- f) Inability of the Contractor to meet a Completion Date, including an anticipated failure to meet a Completion Date entitling the Owner to withhold anticipated Liquidated Damages in accordance with paragraphs 13.15 and 13.17 hereof.
- g) Failure to furnish Submittal as required by the Contract Documents on a timely basis in accordance with the Submittal Register.
- h) Such other reason as to the Designer may appear prudent, proper, or equitable. When grounds for withholding certification have been corrected, the Designer shall so certify to the Owner and the Owner shall make any payment due with respect to such certification as a part of his next payment after such certification.

20.6 No certificate issued or progress payment made shall constitute an acceptance of the Work or any part thereof.

20.7 The amount certified by the Designer for payment shall be ninety-five percent (95%) of the value of Work completed and materials stored since the Designer's last certification as shown on the Request for Payment, less any amounts not certified in accordance with paragraph 20.4, and this amount shall be paid by the Owner on or before the last business day of the month, but payment shall not be past due until not paid within fifteen (15) days thereafter.

20.8 After certification by the Designer that the Work is fifty percent (50%) complete, based on a determination that the Contractor's gross project invoices, excluding the value of materials stored off-site, equal or exceed fifty percent (50%) of the value of the Contract, (except the value of materials stored on-site shall not exceed twenty percent (20%) of the Contractor's gross project invoices for the purpose of determining whether the Project is fifty percent (50%) complete) and the Contractor has provided to the Owner the written consent of its sureties to the cessation of further percentage retention, the amount certified for payment with respect to subsequent Requests for Payment shall be one hundred percent (100%) of the value of Work completed and materials stored since the Designer's last certification as shown on the Request for Payment, less any amounts not certified in accordance with paragraphs 20.4 and 20.5; provided, however, that the aggregate of periodic payments shall not exceed ninety-seven and one half percent (97.5%) of the Contract Price. If the Owner determines that the Contractor's performance under the Contract is unsatisfactory, the Owner may resume withholding percentage retention from each subsequent periodic payment application up to the maximum amount of five percent (5%) of the Contract Price.

## ARTICLE 21. FINAL PAYMENT

21.1 If the Work of the Contractor is limited to demolition, pilings, caissons and structural steel, the remaining unpaid balance of the Contractor's Contract Price, less a sum equal to five-tenths percent (0.5%) of the Contract Price, shall be paid within sixty days following receipt of the following documents, all of which must be received before payment shall become due: (i) request for payment from the Contractor; (ii) receipt of consent from the Contractor's surety to the payment; and (iii) approval or certification from the Designer that the work performed by the Contractor is acceptable and in accordance with the Contract Documents.

21.2 Except as set forth in paragraph 21.1, within forty five days after Substantial Completion of the Project, the remaining unpaid balance of the Contract Price shall be paid to the Contractor, less an amount equal to two and one-half times the value of punch list work or other work remaining to be completed or corrected, as reasonably estimated by the Owner.

21.3 Upon Substantial Completion, the Designer shall prepare and submit to the Contractor a deficiency list identifying all portions of the Work which are known by the Designer at that time to be incomplete or defective. Within thirty (30) days of receipt of this deficiency list, the Contractor shall complete and correct all items on that list along with all other Work required to achieve Final Completion of the Work. At any time prior to completion of the period of warranty, the Designer may submit to the Contractor a supplemental deficiency list, in which case the Contractor shall complete or correct any and all new items identified on the supplemental deficiency list within the time period stipulated in paragraph 18.3.

21.4 Final Payment of any remaining balance of the Contract Price shall not be due to the Contractor until the Contractor achieves Final Completion of the Project.

21.5 The making and acceptance of Final Payment shall constitute a waiver of all claims by the Owner except:

- a) Claims arising from unsettled liens or claims against the Contractor.
- b) Defective Work or materials appearing after Final Payment.
- c) Failure of the Contractor to perform the Work in accordance with the Contract Documents.
- d) As conditioned in the Performance Bond.
- e) Claims made prior to Final Payment which remain unsettled.
- f) Amounts due arising under Articles 18 and 28.
- g) Claims for recovery of overpayment based upon incorrect measurement, estimate, or certificate.

21.6 The making and acceptance of Final Payment shall constitute a waiver of all claims by the Contractor except those claims previously made in writing pursuant to paragraph 15.2 and not finally resolved.

21.7 The Designer shall not authorize Final Payment until all of the Work under the Contract Documents has been certified by the Designer as completed, proper and suitable for occupancy and use, and has been approved by all federal, state and local agencies having jurisdiction.

21.8 The final Request for Payment shall be identified on its face as such and shall be presented by the Contractor to the Designer within thirty (30) days of completion of the Work. Final payment of the retained amount due the Contractor shall be made by the Owner within thirty (30) days after the later of (i) full and Final Completion of all Work required by the Contract Documents, and certification of such Work in accordance with paragraph 20.4; (ii) submission of the affidavits of other documentation required by Article 22; (iii) submission by the Contractor of a Request for Payment identified on its face as final and including the Designer's certification.

## **ARTICLE 22. CONTRACTOR, SUBCONTRACTOR AND SUPPLIER AFFIDAVIT**

22.1 The Final Payment due the Contractor on account of the Contract Documents shall not become due until the Contractor has furnished to the Owner through the Designer: (A) an affidavit by the Contractor signed, sworn, and notarized to the effect that all payments for materials, services, or for any other reason in connection with the Work or performance of the Contract Documents have been satisfied and that no claims or liens exist against the Contractor in connection with the same; (B) affidavits from each Subcontractor and supplier signed, sworn, and notarized to the effect that (i) each such Subcontractor or supplier has been paid in full by the Contractor for all Work performed and materials supplied by him in connection with the Project, and (ii) that all payments for materials, services, and for any other reason in connection with the subcontract or supply contract have been satisfied and that no claims or liens exist against the Subcontractor or supplier in connection therewith; and (C) the written consent of the Contractor's sureties to Final Payment. In the event that the Contractor cannot obtain an affidavit, as required above, from any Subcontractor or supplier, the Contractor shall state in the Contractor's affidavit that no claims or liens exist against such Subcontractor or supplier to the best of the Contractor's knowledge, and that if any appear afterwards, the Contractor shall save the Owner harmless for all costs and expenses, including attorneys' fees, on account thereof.

## **ARTICLE 23. ASSIGNMENTS AND SUBCONTRACTS**

23.1 The Contractor shall not assign any portion of this Agreement nor subcontract the Work in its entirety without the prior written consent of the Owner. Except as may be required under terms of the bonds required by the Contract Documents, no funds or sums of money due or to become due to the Contractor under the Contract Documents may be assigned.

## **ARTICLE 24. MEASUREMENTS**

24.1 Before ordering material or doing Work which is dependent for proper size or installation upon coordination with building conditions, the Contractor shall verify all dimensions and shall be responsible for the correctness of same. No consideration will be given for any claim based on differences between the actual dimensions and those indicated in the Contract Documents. Any discrepancies between the Contract Documents and the existing conditions shall be referred to the Designer for adjustment before any Work affected thereby is begun.

## **ARTICLE 25. CONTRACTOR AND SUBCONTRACTOR RELATIONSHIPS**

25.1 Within thirty (30) days after initial receipt of the Construction Contract for signatures the Contractor shall submit to the Designer and Owner for acceptance a current list of the names of Subcontractors and such other persons and organizations (including those who are to furnish materials or equipment fabricated to a special design) proposed for any and all portions of the Work. The Contractor shall provide this list at this time even if the Contractor was required to submit a list of proposed Subcontractors with the Contractor's bid. The Designer shall promptly reply to the Contractor in writing stating whether or not the Owner or the Designer, after due investigation, has objection to any such proposed person or entity or if it needs additional information to evaluate the persons on the list. Failure of the Designer to reply within ten (10) days after the Contractor has furnished all required information shall constitute notice of no objection.

The Contractor shall not contract with any such proposed person or entity to whom the Owner or the Designer has made reasonable objection. If the Designer or Owner has reasonable objection to any such proposed person or entity, the Contractor shall submit a substitute to whom the Owner and the Designer have no reasonable objection. The Contractor shall make no substitution for any Subcontractor, person, or entity previously allowed without first notifying the Designer and Owner in writing and no substitution may be made if the Owner or Designer makes a reasonable objection to such substitution.

25.2 The Contractor agrees that the terms of the Contract Documents, including all portions thereof, shall apply to all Subcontractors of the Contractor as if they were the Contractor, and that the Subcontractors of the Contractor shall, by means of their subcontracts, be bound by all the terms of the Contract Documents including, but not limited to, Article 26 of these General Conditions.

25.3 Payments to Subcontractors shall be made in accordance with the provisions of N.C. Gen. Stat. §143-134.1.

## **ARTICLE 26. USE OF PREMISES**

26.1 The Contractor shall confine apparatus, the storage of materials, the operations of workers, and the disposal of material to limits indicated by law, ordinances, permits, and directions of the Designer, if any.

26.2 The Contractor shall not load or permit any part of the Work to be loaded with a weight that will endanger its safety, intended performance, or configuration.

26.3 The Contractor shall enforce all of the Designer's instructions, including, but not limited to, those regarding signs, advertisements, fires, and smoking.

## **ARTICLE 27. CUTTING, PATCHING AND FITTING**

27.1 The Contractor shall do all cutting, fitting, and patching of the Work that may be required to make its several parts come together properly and fit it to receive or to be received by Work shown in or which can be reasonably implied from the Contract Documents.

## ARTICLE 28. DISPUTE RESOLUTION

28.1 The laws of the State of North Carolina shall apply to the interpretation and enforcement of this Agreement. Any and all suits or actions to enforce, interpret, or seek damages with respect to any provision of, or the performance or nonperformance of, this Agreement shall be brought in the General Court of Justice of North Carolina sitting in Orange County, North Carolina, and it is agreed by the parties that no other court shall have jurisdiction or venue with respect to such suits or actions. In any dispute arising pursuant to the terms of this Agreement the Parties shall follow and abide by the Rules and Procedures for Orange County Design, Building Construction, Renovation, and Repair Projects. The policy is incorporated herein by reference and may be viewed at [http://www.orangecountync.gov/departments/purchasing\\_division/contracts.php](http://www.orangecountync.gov/departments/purchasing_division/contracts.php)). Regardless of the outcome of any dispute each Party shall be responsible for its own legal costs including reasonable attorneys' fees.

28.2 Any person or firm that expressly or impliedly agrees to perform labor or services or to provide material, supplies, equipment, work, performance or payment bonds, insurance or indemnification for the construction of the Project or the Work shall be deemed a party to this Agreement solely for the purpose of this Article 28. The Contractor, by means of its subcontracts, shall specifically require its Subcontractors to be bound by this Article.

## ARTICLE 29. TAXES

29.1 The Contractor has included in the Contract Price and shall pay all taxes assessed by any authority on the Work or the labor and materials used therein. The Contractor shall maintain all tax records during the life of the Project and furnish the Owner with a complete listing of all taxes paid by taxing authority, invoice number, date, amount, etc. in a form acceptable to the Owner. The Contractor is required to maintain a file showing taxes paid on the Project for three (3) years after Final Payment or turn said documents over to the Owner for his files.

29.2 The following is a list of requirements to be followed by the Contractor in maintaining proper records and reporting the North Carolina Sales and Use Tax and Local Sales and Use Tax. The Contractor shall comply fully with the requirements outlined below, in order that the Owner may recover the amount of the tax permitted under the law.

a) It shall be the Contractor's responsibility to furnish the Owner documentary evidence showing the materials used and sales and use tax paid by the Contractor and each of his Subcontractors. Such evidence shall be transmitted to the Owner with each pay request regardless of whether taxes were paid in that period.

b) The documentary evidence shall consist of a certified statement by the Contractor and each of the Contractor's Subcontractors individually, showing total purchases of materials from each separate vendor and total sales and use taxes paid to each vendor. Certified statements must show the invoice number, or numbers, covered, and inclusive dates of such invoices.

c) Materials used from Contractor's or Subcontractor's warehouse stock shall be shown in a certified statement at warehouse stock prices.

d) The Contractor shall not be required to certify the Subcontractor's statements.

## **ARTICLE 30. OPERATION OF OWNER'S FACILITIES**

30.1 The Contractor agrees that all Work done under the Contract Documents shall be carried on in such a manner so as to ensure the regular and continuous operation of the adjoining or adjacent facilities. The Contractor further agrees that the sequence of operations under the Contract Documents shall be scheduled and carried out so as to ensure said regular and continuous operation. The Contractor shall not close any areas of construction until so authorized by the Designer. The Contractor shall control operations to assure the least inconvenience to the public. Under all circumstances, safety shall be the most important consideration.

## **ARTICLE 31. THIRD PARTY BENEFICIARY CLAUSE**

31.1 It is specifically agreed between the parties executing the Agreement that, with the specific exception set forth paragraph 7.24 hereof, and that exception only, the Contract Documents and the provisions therein are not intended to make the public, or any member thereof, or any other individual or entity, a third-party beneficiary of the Agreement, or to authorize anyone not a party to the Contract Documents to maintain a suit for personal injuries or property damage pursuant to the terms of provisions of the Contract Documents.

## **ARTICLE 32. MEASUREMENT OF QUANTITIES**

32.1 All Work completed under the Contract Documents shall be measured by the Contractor using United States customary units of measurement. The method of measurement and computations to be used in determination of quantities of material furnished and of Work performed under the Contract Documents shall be those methods set forth in the Contract Documents or, if not specifically set forth therein, the method generally recognized as conforming to good engineering practice.

## **ARTICLE 33. TERMINATION BY THE OWNER FOR CAUSE**

33.1 If the Contractor fails to begin or complete the Work under the Contract Documents within the time specified, or fails to perform the Work with sufficient labor and equipment or with sufficient materials to insure the prompt completion of said Work, or shall perform the Work unsuitably or shall discontinue the prosecution of the Work for three (3) days, or if the Contractor shall become insolvent, be declared bankrupt, commit any act of bankruptcy or insolvency, allow any final judgment to stand against the Contractor or its affiliated companies unsatisfied for a period of forty-eight (48) hours, make an assignment for the benefit of creditors, or for any other cause whatsoever shall not carry on the Work in an acceptable manner, the Owner may give notice in writing to the Contractor and the Contractor's sureties of such delay, neglect, or default, specifying the same, and if the Contractor within a period of three (3) days after such notice shall not proceed in good faith and with reasonable speed to correct such delay, neglect, or default in accordance with such notice, the Owner shall have full power and authority, to the extent permitted by law, without violating the Contract Documents, to take the prosecution of the Work out of the hands of the Contractor, to appropriate or use any or all materials and equipment at the Project as may be suitable and acceptable, and may enter into an agreement for the completion of the Work or pursue such other methods as in the Owner's opinion shall be necessary or appropriate for the completion of the Work in an acceptable

manner. All costs and charges incurred by the Owner in proceeding in accordance with the preceding sentence, including attorney's fees, and all costs incurred by the Owner in completing the Work shall be deducted from any money due or which becomes due the Contractor. If such costs and expenses incurred by the Owner shall be less than the sum which would have been payable under Contract Documents if it had been completed by the Contractor, then the Contractor shall be entitled to receive the difference, but if such costs and expenses shall exceed the sum which would have been payable under the Contract Documents, the Contractor and the Contractor's surety shall be liable to the Owner for and shall pay to the Owner the amount of such excess.

#### **ARTICLE 34. TERMINATION OR SUSPENSION BY THE OWNER FOR CONVENIENCE**

34.1 The Owner may, without cause, order the Contractor to terminate, suspend, delay, or interrupt the Work in whole or in part for such period of time as the Owner may determine. The Owner may terminate the Agreement upon seven (7) days written notice to the Contractor for the Owner's convenience and without further liability or obligation to the Owner.

34.2 If the Contractor is subsequently ordered by the Owner to resume the Work, any cost or expenses to which the Contractor may be entitled by reason of the suspension, delay, or interruption shall be recovered by means of a Change Order in accordance with Articles 13 and 14 hereof and the Contract Construction Schedule shall be adjusted in accordance with Article 13 hereof.

34.3 In the event of termination by the Owner under this Article, the Contractor shall be entitled to receive the reasonable and documented direct costs incurred prior to termination, including the cost of materials purchased for the Work which purchases cannot be canceled or which material cannot reasonably be used by the Contractor on other work, and the cost of closing down the Project in a safe and efficient manner, plus ten percent (10%) thereof for overhead and profit, subject to the following conditions:

a) When the Contract is terminated before completion of all items of Work, payment shall be made for the actual number of units or items of Work completed at the applicable contract prices, or as mutually agreed for items of Work partially complete. If a mutual agreement cannot be reached, the Owner shall have the authority to make such equitable adjustment as it deems warranted and the Final Payment shall be made accordingly.

b) Reimbursement for organization of any Work and moving equipment to and from the job shall be considered when not otherwise provided for in the Contract Documents where the volume of completed Work is too small to compensate the Contractor for those expenses under unit prices. If a mutual agreement cannot be reached, the Owner will have the authority to make such equitable adjustments as it deems warranted and the Final Payment will be made accordingly.

c) Materials obtained by the Contractor for the Work that have been inspected and accepted by the Designer and that are not incorporated in the Work shall, at the request of the Contractor, be purchased from the Contractor at the Contractor's actual cost as shown by receipted bills and actual costs records at such points of delivery as may be determined by the Owner.

d) No payment shall be made by Owner to Contractor except as herein above provided. No claim for loss of anticipated profits shall be considered or allowed.

e) Termination of the Contract shall not relieve the Contractor of his responsibilities for any completed portion of the Work nor shall it relieve his sureties of their obligation for and concerning any just claims arising out of the Work performed. The Contractor shall not be entitled to any other compensation, including compensation for lost profit, lost opportunity, or any other direct or consequential cost, loss, or damage.

f) Either party may terminate this Agreement upon notice to the other party that obligations pursuant to this Agreement are made impossible due to declarations of emergency by Orange County or by North Carolina due to events directly impacting Orange County. Both parties shall remain responsible for all payment and performance due up to the receipt of such notice, but shall have no further obligation or responsibility beyond that date provided the terminating party has taken all reasonable steps to complete the performance of its obligations.

### **ARTICLE 35 MINORITY BUSINESS ENTERPRISE PROGRAM**

35.1 The Contractor shall at all times comply with the Orange County Minority Business Enterprise Policy. All documentation substantiating compliance with the requirements of this program shall be delivered to the Owner as stipulated in the Contract Documents. A copy of the Orange County Minority Business Enterprise Policy is included in the Project Manual.

### **ARTICLE 36 E-VERIFY AND DIGITAL SIGNATURES**

36.1 By executing the Agreement Contractor affirms Contractor, its agents and subcontractors, are and shall remain in compliance with Article 2 of Chapter 64 of the North Carolina General Statutes.

36.2 This Agreement together with any amendments or modifications may be executed electronically. All electronic signatures affixed hereto evidence the consent of the Parties to utilize electronic signatures and intent of the Parties to comply with Article 11A and Article 40 of North Carolina General Statute Chapter 66.

36.3 By executing the Agreement Contractor certifies that Contractor has not been identified, and has not utilized the services of any agent or subcontractor identified, on the list created by the State Treasurer pursuant to G.S. 147-86.58.

36.4 By executing the Agreement Contractor certifies that Contractor has not been identified, and has not utilized the services of any agent or subcontractor identified, on the list created by the State Treasurer pursuant to G.S. 147-86.81.

### **ARTICLE 37 GENERAL**

37.1 If any provision of the Agreement shall be declared invalid or unenforceable, the remainder of the Agreement shall continue in full force and effect.

37.2 The titles to Articles herein are for convenience only, are not substantive parts of the General Conditions, and are not to be considered in interpreting the Contract Documents.

**END OF GENERAL CONDITIONS OF THE CONTRACT FOR CONSTRUCTION—EXHIBIT 1**

## GENERAL PROVISIONS

This contract is for the following: **Paving, Incidental Milling, Removing Asphalt/Tree Root, Pouring ADA Concrete Parking Spaces, Removing and Replacing Wooden Wheel Bump Stops, Installing Truncated Domes, Installing 15” Drainage Pipe, Laying Gravel, Installing Surface-Mounted Speed Bumps, and Parking Lot Re-Striping.**

All work and materials shall be in accordance with the provisions of the General Guidelines of this contract, the Project Special Provisions, the North Carolina Department of Transportation NCDOT 2024 Standard Specifications for Roads and Structures, and the North Carolina Department of Transportation Roadway 2024 Standard Drawings.

The Contractor shall keep himself fully informed of all Federal, State and local laws, ordinances, and regulations, and shall comply with the provisions of Section 107 of the NCDOT Standard Specifications.

## CONTRACT TIME AND LIQUIDATED DAMAGES

**The date of availability for this project will be the Date of the Notice to Proceed.** The Contractor may begin work prior to this date upon approval of the Engineer or his duly authorized representative. If such approval is given, and the Contractor begins work prior to the date of availability, the Orange County - Little River Park will assume no responsibility for any delays caused prior to the date of availability by any reason whatsoever, and such delays, if any, will not constitute a valid reason for extending the completion date.

No work will be permitted, and no purchase order will be issued until all required bonds and prerequisite conditions and certifications have been satisfied.

**The completion date for this project is June 5<sup>th</sup>, 2026.** No extensions will be authorized except as authorized by Article 108-10 of the NCDOT 2024 Standard Specifications.

**Liquidated damages for this contract are Five Hundred Dollars (\$500.00) per calendar day.**

## PROSECUTION OF WORK AND LIQUIDATED DAMAGES

(7-1-95) RG 15

The provisions of section 108 of the 2024 NCDOT Standard Specifications shall apply with the following additions:

The Contractor will be required to pursue the work in a continuous and uninterrupted manner from the time he begins the work until completion and final acceptance of the

work. The Contractor will not be permitted to suspend his operations except for reasons beyond his control or except where the Engineer has authorized a suspension of the Contractor's operations in writing. In the event that the Contractor's operations are suspended in violation of the above provisions, the sum of **Two Hundred Fifty Dollars (\$250.00)** will be charged to the Contractor for each and every calendar day that such suspension takes place. The said amount is hereby agreed upon as liquidated damages due to extra engineering and maintenance costs and due to increased public hazard resulting from a suspension of the work. Liquidated damages chargeable due to suspension of the work will be additional to any liquidated damages that may become chargeable due to failure to complete the work on time.

### **USE OF SITE**

It is the responsibility of the contractor to backfill all tripping hazards and/or barricade unsafe areas to ensure the safety of others due to non-completion of work.

The Liquidated Damages are **Six Hundred Dollars (\$600.00)** per hour.

\*\*\* For a contractor not to be liable for damage to newly placed concrete or asphalt an effort **MUST** be made by the contractor to protect/barricade newly poured concrete or newly placed asphalt if curing/drying time is required \*\*\*

### **PUBLIC NOTIFICATION**

The Contractor shall provide a construction schedule and give at least 2 weeks' notice before work is to begin, so that public notification can be placed.

### **DISPUTE RESOLUTION**

Either the Owner or the Contractor may seek such remedies as are available to it by law for any disputes which they are unable to mutually resolve, and the venue for any legal action shall be in the court with jurisdiction over the matter in Orange County, NC.

### **TWELVE MONTH GUARANTEE**

The Contractor shall guarantee materials and workmanship against latent and patent defects arising from faulty materials, faulty workmanship or negligence for a period of twelve months following the date of final acceptance of the work for maintenance and shall replace such defective materials and workmanship without cost to the Orange County - Little River Park. The Contractor will not be responsible for damage due to faulty design, normal wear and tear, for negligence on the part of the Orange County -Little River Park, and/or for use in excess of the design. This guarantee provision shall be invoked only for major components of work in which the Contractor would be wholly responsible for under the terms of the contract. This provision will not be used as a mechanism to force the Contractor to return to the project to make repairs or perform additional work that the Orange County - Little River Park would normally compensate the Contractor for. In addition, routine maintenance activities (i.e. mowing grass, debris removal, ruts in earth shoulders,) are not parts of this guarantee. Appropriate provisions of the payment and/or performance bonds shall cover this guarantee.

## **SPECIAL PROVISIONS**

### **ASPHALT TACK COAT:**

Tack Coat should be applied in accordance with Section 605 of the NCDOT Standard Specifications. No separate payment will be made for this material as it is considered incidental and should be included in the unit price for "S9.5 B."

### **ASPHALT CEMENT AND NON-STRIP ADDITIVE:**

The asphalt cement and any non-strip additive will be included in the price bid for asphalt mix.

### **BITUMINOUS PAVER:**

The Contractor's attention is directed to Article 610-8 of the NCDOT Standard Specifications dealing with automatically controlled screeds on the bituminous pavement spreaders. Pavers shall be equipped with a screed control system which will automatically control the longitudinal profile and cross slope of the pavement.

### **PAVING:**

The production, delivery, placement, and compaction of all bituminous material shall be in accordance with the NCDOT's 2024 Standard Specifications Asphalt Concrete Plant Mix Pavements – Section 610. A currently approved North Carolina Department of Transportation job mix formula shall be used for all bituminous construction. The air temperature 48 continuous hours prior to paving must be above 32 degrees Fahrenheit. Air temperature at the time of paving shall be in accordance with Article 610-4 of the NCDOT's 2024 Standard Specifications. Minimum air temperature for resurfacing shall be 40 degrees and rising and the minimum surface temperature shall be 50 degrees. The Contractor shall compact the bituminous material on this project in accordance with Article 610-9 of the 2024 NCDOT Standard Specifications. When asphalt is placed on sub grade or stone, pavement shall not be placed until the base has been approved by the Engineer or his representative. The contractor will be required to provide a Dump Truck sufficiently loaded to perform proof rolling on Sub grade and on Aggregate Base Course. The Contractor shall use a stringline or other approved method to establish a uniform consistent line to locate the edge of pavement. It shall be the Contractor's responsibility to place such line, but it shall meet the approval of the Engineer or his representative. Payment shall be made for this item under the unit price for "S9.5 B" is full compensation for all labor equipment and materials (including Asphalt Binder for Plant Mix) required to furnish, place compact and finish the proposed asphalt pavement.

**Pay Item**  
S9.5B

**Pay Unit**  
Ton

**MILLING ASPHALT PAVEMENT:**

Perform the work covered by this section including, but not limited to, milling and re-milling the pavement at locations, depths, widths and typical sections indicated in the contract; cleaning the milled surface; loading, hauling and stockpiling the milled material for use in recycled asphalt mixtures; and disposal of any excess milled material.

Except where the milled material is used in the work or where otherwise directed, provide areas outside the right of way to dispose of milled material, which shall be property of the Contractor.

**Equipment**

Use a self-propelled unit capable of removing the existing asphalt pavement to the depths, widths and typical sections shown in the contract. Use milling machines designed and built exclusively for pavement milling operations and with sufficient power, traction and stability to accurately maintain depth of cut and slope. Use milling machines equipped with an electronic control system that will automatically control the longitudinal profile and cross slope of the milled pavement surface. Accomplish this through the use of a mobile grade reference, an erected string line, joint matching shoe, slope control systems or a combination of approved methods. Use an erected fixed stringline when required by the contract.

Otherwise, use a mobile grade reference system capable of averaging the existing grade or pavement profile over at least 30 ft. Use either a non-contacting laser or sonar type ski systems with at least 4 referencing stations mounted on the milling machine at a length of at least 24 ft. Coordinate the position of the grade control system such that the grade sensor is at the approximate midpoint of the mobile reference system. Use a machine capable of leaving a uniform surface suitable for handling traffic without damage to the underlying pavement structure. Use a milling machine and other loading equipment capable of loading milled material to be used in other parts of the work without segregation.

Provide additional equipment necessary to satisfactorily remove the pavement in the area of manholes, water valves, curb, gutter and other obstructions.

Equip the milling equipment with a means of effectively limiting the amount of dust escaping from the removal operation in accordance with Federal, State and local air pollution control laws and regulations.

**Construction Methods**

Mill the existing pavement to restore the pavement surface to a uniform longitudinal profile and cross section in accordance with typical sections shown in the plans. Where indicated in the contract, remove pavement to a specified depth and produce a specified cross slope. Mill intersections and other irregular areas unless otherwise directed by the Engineer.

The Contractor may elect to make multiple cuts to achieve the required depth of cut or cross slope required by the plans.

Establish the longitudinal profile of the milled surface by a mobile string line on the side of the cut nearest the centerline of the road. Establish the cross slope of the milled surface by an automatic cross slope control mechanism or by a second skid sensing device located on the opposite edge of the cut. The Engineer may waive the requirement for automatic grade and cross slope controls where conditions warrant.

Operate the milling equipment so as to prevent damage to the underlying pavement structure, utilities, drainage facilities, curb and gutter, paved surfaces outside the milled area and any other appurtenances. Produce milled pavement surfaces that are reasonably smooth and free of excessive scarification marks, gouges, ridges, continuous grooves or other damage. Repair

any leveling or patching required as a result of negligence by the Contractor with hot asphalt plant mix in a manner acceptable to the Engineer. Coordinate the adjustment of manholes, meter boxes and valve boxes with the milling operation in accordance with Article 858-3 including a temporary asphalt ramp.

When necessary, the contractor may remove the top section of a utility and use a bridge steel plate placed to cover the entire width of the structure, ensuring no debris is dropped inside the structure. Backfill with compacted material and hot mix asphalt as a temporary riding surface as well as any further necessary requirements of the utility owner. This steel plate must be capable of carrying any traffic load carried by the facility. Where necessary, double-reference the location of each structure that has been removed and maintain a map of their location.

Construct a temporary ramp of asphalt plant mix to extend a minimum of 3 ft around raised structures before opening to traffic.

The Engineer may require re-milling of any area exhibiting laminations or other defects. Thoroughly clean the milled pavement surface of all loose aggregate particles, dust and other objectionable material. Disposing or wasting of oversize pieces of pavement or loose aggregate material will not be permitted within the right of way.

Conduct pavement removal operations so as to effectively minimize the amount of dust being emitted. Plan and conduct the operation so it is safe for persons and property adjacent to the work including the traveling public.

### **Tolerance**

Remove the existing pavement to the depth required by the contract. The Engineer may vary the depth of milling.

### **Measurement and Payment**

#### **(A) Incidental Milling**

Where the Contractor is required to re-mill areas that are not due to the Contractor's negligence and whose length is less than 100 ft or butt joints that are not a portion of the milling areas outlined in Subarticle 607-5(B), measurement will be made as provided in Subarticle 607-5(A) for each cut he is directed to perform. Where the Contractor elects to make multiple cuts to achieve the final depth, no additional measurement will be made. Compensation will be made at the contract unit price per square yard for Incidental Milling.

#### **(B) Milling of Defects**

If defects are determined to be the result of the Contractor's negligence, then measurement for the re-milling or repairs will not be made. If the Engineer directs re-milling of an area that is equal to or greater than 100 ft and is not due to the Contractor's negligence, the re-milled area will be measured as provided in Subarticle 607-5(A) and paid at the contract unit price per square yard for Milled Asphalt Pavement, \_\_\_" Depth or Milling Asphalt Pavement, \_\_\_" to \_\_\_".

### **Pay Item**

Incidental Milling

### **Pay Unit**

Square Yard

**REMOVE AND REPLACE WOODEN WHEEL BUMP STOPS (4X6):**

Furnish, install, move, and remove wheel bump stops as shown on the plans, as provided for in the specifications for this project, or as directed.

**Materials**

Provide new materials, if necessary, that comply with the requirements of this specification, and pertinent requirements of the following items:

Provide wheel bump stops a minimum of 6 ft. long unless otherwise shown on the plans or as approved.

**Construction**

Remove existing wheel bump stops. Furnish a new wheel bump stop and install in accordance with the plan details or as directed.

**Pay Item**

Remove and Replace Wooden Wheel Bump Stops (4x6)

**Pay Unit**

Each

**PAINT:**

**Application Equipment**

The equipment to apply paint to pavements shall be a truck mounted pneumatic or airless spray machine with suitable arrangements of atomizing nozzles and controls to obtain the specified markings. Paint pavement markings application equipment shall be capable of placing double solid lines, single solid lines, intermittent skip lines or a combination of solid and intermittent skip lines in a single pass. This equipment shall also have an internal timing mechanism for measurement and controlled output of required line lengths. The paint applicator equipment shall have at least two paint tanks with a minimum 60 gallon capacity.

**Measurement and Payment**

Pavement Marking Lines will be measured and paid as the actual number of linear feet of pavement marking lines satisfactorily placed and accepted by the Engineer. In addition, Paint Pavement Marking Lines will be paid per linear foot for each 15 mil application placed. The quantity of solid lines will be the summation of the linear feet of solid line measured end-to-end of the line. Payment at the contract unit price for the various items in the contract will be full compensation for all the items covered by this section. No direct payment will be made for the work involved in applying the lines, including surface preparation; reapplication of molten pavement marking crossed by a vehicle. Replacement of pavement markings that prematurely deteriorated, failed to adhere to the pavement, lacked reflectorization or were otherwise unsatisfactory during the life of the project or during the 12 month observation period as determined by the Engineer will be at no cost to Little River Park. Payment for Paint Pavement Marking Lines required to winterize the project will be made in accordance with Article 1205-10 except that no payment will be made on resurfacing projects where paving is completed more than 30 days before the written notification by Little River Park that winterization is required.

**Pay Item**

4" White Pavement Marking Lines  
24" White Pavement Marking Lines  
Handicap Symbols  
Paint Symbols (Arrows)

**Pay Unit**

Linear Foot  
Linear Foot  
Each  
Each

**INSTALL 15” DRAINAGE PIPE:**

Where shown in the plans, the Contractor may use reinforced concrete pipe, aluminum alloy pipe, aluminized corrugated steel pipe, galvanized corrugated steel pipe, HDPE pipe, polypropylene pipe or PVC pipe in accordance with the following requirements.

**Materials**

Refer to Division 10.

Item	Section
Aluminized Corrugated Steel Pipe	1032-3(A)(7)
Corrugated Aluminum Alloy Pipe	1032-2(A)
Corrugated HDPE Pipe	1032-7
Polypropylene Pipe	1032-4
Elbows	1032
PVC Pipe	1032-8
Reinforced Concrete Pipe, Class II, III, IV, or V	1032-6(B)

Corrugated steel pipe will not be permitted in counties listed in Article 310-2. Only pipe with smooth inside walls will be allowed for storm drain systems. Define “storm drain systems” as pipe under curb and gutter, expressway gutter and shoulder berm gutter that connects drainage structures and is not open ended. Corrugated pipe without a smooth interior is only for use at storm drain system inlets and outlets if pipe slope is greater than 10%.

**Construction Methods**

Install pipe culverts in accordance with Section 300. Where allowed by the plans, use any of the several alternate pipes shown herein, but only one type of pipe and elbow will be permitted between drainage structures or for the entire length of a cross line pipe.

**Measurement and Payment**

12" Drainage Pipe will be measured and paid as the actual number of linear feet of pipe that has been incorporated into the completed and accepted work. Measurement of pipe will be made by counting the number of joints used and multiplying by the length of the joint to obtain the number of linear feet of pipe installed and accepted. Measurements of partial joints will be made along the longest length of the partial joint to the nearest 0.1 foot. Select bedding and backfill material will be included in the cost of the installed pipe.

**Pay Item**

Install 15” Drainage Pipe

**Pay Unit**

Linear Foot

**1.5” BORROW:**

Excavate approved material from borrow sources. Haul and use such material as required in the plans or as directed by the Engineer. Do not use borrow excavation until all available suitable unclassified excavation has been incorporated into the embankments, subgrades and shoulders except by execution of a supplemental agreement documenting the conditions prescribed below.

- (A) All suitable unclassified excavation wasted as a result of the early use of borrow material will be deducted from the total volume of borrow excavation paid under the contract.
- (B) Reimburse the Department for all additional costs, including additional engineering cost, associated with the wasting of suitable unclassified excavation.
- (C) Any claim for contract time extensions related to the early use of borrow is waived should the Contractor use borrow material before all suitable unclassified excavation being incorporated into the project pursuant to a supplemental agreement.
- (D) The Contractor specifically waives rights to request additional compensation with regard to the early use of borrow under the compensation requirements of Section 104 except when unclassified excavation is a major contract item and that unclassified excavation overruns by more than 25%.

Where the work required to complete the project is so phased by the plans to preclude using suitable unclassified excavation, the Contractor will be permitted to construct the required embankments, subgrades or shoulders so controlled by the phasing from approved borrow materials without having to execute the above required supplemental agreement.

**Coordination with Seeding Operations**

Coordinate the work in this section with the construction of embankments in accordance with Article 225-2.

**Materials**

Refer to Division 10.

**Pay Item**

1.5” Borrow

**Pay Unit**

Cubic Yard

**ADA CONCRETE PARKING PAVEMENT:**

Perform the work covered by this section, including, but not limited to, designing the concrete mix; furnishing and placing concrete; furnishing of all admixtures and additives; constructing all joints and furnishing joint materials; marking the pavement; curing the pavement and furnishing all curing materials; furnishing concrete necessary for making test beams and cylinders; performing maturity testing; coring and patching the pavement; calibrating and checking the operation of batching equipment; taking actions necessary to prevent or to repair cracking; sawing and sealing joints; verifying dowel bar alignment; removing and replacing of defective pavement; and constructing Portland cement concrete pavement in accordance with these Standard Specifications and with the lines, grades and dimensions shown on the plans.

**Materials**

Refer to Division 10.

Item	Section
Curing Materials	1026
Dowels and Tie Bars	1070-6
Joint Filler	1028-1
Low Modulus Silicone Sealant	1028-3
Portland Cement Concrete	1000
Water	1024-4

**Composition of Concrete**

Design the concrete mix in accordance with Section 1000.

**Construction Methods**

Construct concrete pavement in accordance with Section 700. Place concrete in 2 lane minimum widths in a single operation except as follows:

- (A) Where the total number of lanes is an odd number, in which case one of the lanes may be placed in a separate operation.
- (B) Areas such as ramps or auxiliary lanes where the total width is less than 2 lanes.

**Finishing**

Screed and float finish the concrete to the required cross section that minimizes or eliminates hand finishing. Additional water for finishing will not be allowed. Hand finishing will not be permitted except under the following conditions:

- (A) Narrow widths or irregular areas, where operation of mechanical equipment is impractical.
- (B) If a breakdown of mechanical equipment occurs, hand methods may be used to finish only that concrete deposited on the base before the breakdown.
- (C) Abnormal circumstances of short duration subject to approval by the Engineer.

Produce a final finish on the pavement surface true to grade and uniform in appearance and free of irregular, rough or porous areas. Following the finishing of the pavement by screeding, floating and checking with straightedges, further finish the surface of the pavement by burlap dragging or other acceptable method to produce a uniform surface texture. Pull the burlap drag in a longitudinal direction. Produce the final surface finish on all mainline pavement, auxiliary lanes, and ramps by mechanical equipment for longitudinally tined grooves while the concrete is plastic. The tining shall be done with a mechanical device such as a wire comb. The comb shall have a single row of tines. Each shall have a nominal width of 5/56 inch to 1/8 inch. The nominal spacing of the tines shall be  $3/4 \pm 1/8$  inch center-to-center. The nominal depth of tined groove in the plastic concrete shall be  $1/8 \pm 1/32$  inch. Longitudinal tining shall be accomplished by equipment with automated horizontal and vertical controls to ensure straight, uniform depth tined grooves. The texture geometry shall be the same as imparted throughout the length of the tining comb. A 2 inch to 3 inch wide strip of pavement surface shall be protected from tining for the length of and centered about longitudinal joints. The tining operation shall be done so that the desired surface texture will be achieved while minimizing displacement of the larger aggregate particles and before the surface permanently sets. Where abutting pavement is to be placed, the tining shall extend as close to the edge as possible without damaging the edge. If abutting pavement is not to be placed, the 6 inch area nearest the edge or 1 foot from the face of the curb shall not be tined. Hand-operated tining equipment that produces an equivalent texture may be used only on small or irregularly shaped areas. Tines shall be thoroughly cleaned at the end of each day's use and damaged or worn tines replaced. When surface corrections for pavement smoothness are made in the hardened concrete, no additional texturing is required. After final finishing, hand finishing may be required on the edges of pavement and joints whenever irregularities in surface texture or alignment occur. Care should be taken in hand finishing pavement edges to avoid ridges or high places that will prevent water from draining out of the transverse grooves. The use of excessive water during the finishing operations will not be permitted. Provide a textured surface with an average texture depth of 0.8 mm as tested in accordance with ASTM E965 with no single test having a texture depth of 0.5 mm or less. Perform 4 randomly located tests in accordance with ASTM E965 within the initial pavement lot of each mobilization in the presence of the Engineer. A "lot" is defined in Article 710-4. If the average of the 4 tests does not meet the above criteria, make appropriate changes to the surface texture operations and test the next lot as detailed above. Once the surface texture process is established to meet minimum texture requirements, maintain consistency within the operation to provide the above minimum texture depth. Perform additional sand patch tests in accordance with ASTM E965 when directed by the Engineer. If the surface texture becomes damaged or reduced by rain or any other action, reestablish or restore surface texture by an approved method.

**Measurement and Payment:**

The quantity of Portland cement concrete pavement to be paid will be the actual number of cubic yards of concrete pavement completed and accepted. In measuring this quantity, the width of the pavement will be as called for on the plans or as directed by the Engineer. The length will be the actual length constructed, measured along the centerline of the pavement.

**Pay Item**

ADA Concrete Parking Pavement

**Pay Unit**

Cubic Yard

\*\*\*\*\*

I, \_\_\_\_\_ (the individual attesting below), being duly authorized by and on behalf of \_\_\_\_\_ (the entity bidding on project hereinafter "Employer") after first being duly sworn hereby swears or affirms as follows:

- 1. Employer understands that E-Verify is the federal E-Verify program operated by the United States Department of Homeland Security and other federal agencies, or any successor or equivalent program used to verify the work authorization of newly hired employees pursuant to federal law in accordance with NCGS §64-25(5).
- 2. Employer understands that Employers Must Use E-Verify. Each employer, after hiring an employee to work in the United States, shall verify the work authorization of the employee through E-Verify in accordance with NCGS§64-26(a).
- 3. Employer is a person, business entity, or other organization that transacts business in this State and that employs 25 or more employees in this State. (mark Yes or No)
  - a. YES \_\_\_\_\_, or
  - b. NO \_\_\_\_\_
- 4. Employer's subcontractors comply with E-Verify, and if Employer is the winning bidder on this project Employer will ensure compliance with E-Verify by any subcontractors subsequently hired by Employer.

This \_\_\_\_ day of \_\_\_\_\_, 20\_\_.

\_\_\_\_\_  
Signature of Affiant  
Print or Type Name: \_\_\_\_\_

State of North Carolina, \_\_\_\_\_ County

Signed and sworn to (or affirmed) before me, this the \_\_\_\_  
day of \_\_\_\_\_, 20\_\_.

My Commission Expires:

\_\_\_\_\_  
Notary Public

(Affix Official/Notarial Seal)

---

Section I:	General Government and Administration
Policy 10.0:	Living Wage Contractor Policy
Reviewed by:	County Attorney/County Manager
Approved by:	County Manager
Original Effective Date:	July 1, 2017
Revisions:	

---

### **Policy Statement**

It is the policy of Orange County to ensure its employees, and all individuals who provide services for Orange County, are paid a living wage.

### **Purpose**

To encourage all vendors and contractors to pay a living wage to all employees who perform work pursuant to a contract with Orange County.

### **Applicability**

Applies to all Orange County contracts and purchases.

### **Policy**

#### 10.1 Living Wage

10.1.1 Orange County is committed to providing its employees with a living wage and encourages all contractors and vendors doing business with Orange County to pursue the same goal. Orange County's living wage is \$14.95 per hour. To the extent possible, Orange County recommends that contractors and vendors seeking to do business with Orange County provide a living wage to their employees.

10.1.2 Prior to final execution of a contract with Orange County all contractors and vendors seeking to do business with Orange County shall submit to the County's representative a statement indicating whether those employees who will perform work on the Orange County contract are paid at least the living wage amount set out above. If such employees do not make at least the living wage amount set out above the contractor or vendor shall indicate in the statement the actual amount paid to such employees. For bid projects this statement should be submitted as part of the bid packet.

**This policy may be reviewed annually and updated as needed by the Manager's Office**

**FORM W-9**  
 [Rev. 1-92; Rev. 10-94  
 for Division Contract Use]

Pursuant to Internal Revenue Service Regulations, vendors must furnish their **Taxpayer Identification Number (TIN)** to the State. **If this number is not provided, you may be subject to a 31% withholding on each payment.** To avoid this 31% withholding and to insure that accurate tax information is reported to the Internal Revenue Service and the State, please use this form to provide the requested information **exactly as it appears on file with the IRS.**

Legal Business Name \_\_\_\_\_

Address \_\_\_\_\_

\_\_\_\_\_

9 Digit Taxpayer Identification Number \_\_\_\_\_

Social Security Number \_\_\_\_\_

Federal Employer Identification Number \_\_\_\_\_

Business Designation (Check One) \_\_\_\_\_ Individual (Soc.Sec. #)  
 \_\_\_\_\_ Sole Proprietorship (Soc.Sec. #)  
 \_\_\_\_\_ Partnership (Fed. ID)  
 \_\_\_\_\_ Estate/Trust (Fed. ID)  
 \_\_\_\_\_ Corporation (Fed. ID)  
 \_\_\_\_\_ Public Service Corporation (Fed. ID)  
 \_\_\_\_\_ Governmental/Non-Profit (Fed. ID)

Under penalties of perjury, I declare that I have examined this request and to the best of my knowledge and belief, it is true, correct, and complete. I have not been notified by the IRS that I am subject to backup withholding for failure to report income.

\_\_\_\_\_  
 Name (Print or Type name of individual-not company) Title (Print or Type)

\_\_\_\_\_  
 Signature Date Telephone Number

ORANGE COUNTY

NORTH CAROLINA

**DISPUTE RESOLUTION RULES AND PROCEDURES FOR ORANGE COUNTY DESIGN, BUILDING  
CONSTRUCTION, RENOVATION, AND REPAIR PROJECTS**

**RULE 1. INITIATING MEDIATED SETTLEMENT CONFERENCES**

**A. Purpose of Mandatory Settlement Conferences.** Pursuant to G.S. §143-128(f1) and 143-135.26(11), these Rules are promulgated to implement a mediated settlement program designed to focus the parties' attention on settlement rather than on claim preparation and to provide an opportunity for orderly settlement negotiations to take place. Nothing herein is intended to limit or prevent the parties from engaging in settlement procedures voluntarily at any time prior to or during commencement of the dispute resolution process.

**B. Initiating the Dispute Resolution Process**

1. Any party to a County public construction contract (referred to herein generally as the "Contract") governed by Article 8. Ch. 143 of the General Statutes and identified in G.S. § 143-128(f1) and who is a party to a dispute arising out of the Contract and the construction process in which the amount in controversy is at least \$15,000 may submit a written request to the County for mediation of the dispute.

2. Prior to submission of a written request for mediation to the County, the party requesting mediation should give notice of any and all claims in accordance with their respective contracts, obtain decisions on the claims as required or allowed by their respective contracts, and attempt to resolve the dispute according to the terms and conditions in their respective contracts. The Mediator may adjourn any mediated settlement conference if the Mediator believes, in his or her sole discretion, that the parties have not satisfied all of the terms and conditions of their respective contracts and that doing so will enhance the prospects for a negotiated settlement.

**C. Condition Precedent to Litigation.** Before any party to a Contract may commence a civil action against the County seeking remedies for breach or non-performance of the Contract by the County, said party must first initiate the dispute resolution process under these rules and attend and participate in good faith in the mediated settlement conference.

**RULE 2. SELECTION OF MEDIATOR**

**A. Mediator Listing.** A List of Mediators acceptable to the County is maintained by the County Attorney and that list is incorporated by reference into these Rules.

**B. Selection of Mediator.** The party requesting mediation shall select a Mediator from the List of Mediators and shall file, with the County, a Notice of Selection of Mediator within 21 days of the request for mediation. Such notice shall state the name, address, and phone number of the Mediator selected. If

the Mediator selected is not available or declines to participate for any reason, the requesting party shall select another person from the List of Mediators. If the party requesting mediation does not select and designate a mediator within 21 days of the request for mediation, the County shall have the right in its absolute discretion to appoint a mediator from its List of Mediators.

**C. Disqualification of Mediator.** Any party may request replacement of the Mediator for good cause. Nothing in this provision shall preclude Mediators from disqualifying themselves.

### **RULE 3. THE MEDIATED SETTLEMENT CONFERENCE**

**A. Where Conference is to be Held.** Unless all parties and the Mediator otherwise agree, the mediated settlement conference shall be held in county seat of Orange County. The Mediator shall be responsible for reserving a place, making arrangements for the conference, and giving timely notice of the time and location of the conference to all attorneys, unrepresented parties and other persons or entities required to attend.

**B. When Conference is to be Held.** The mediation shall be completed within 90 days after selection of the Mediator unless all parties to the mediation agree to a different schedule.

**C. Request to Accelerate or Extend Deadline for Completion.** Any party or the Mediator may request the County to accelerate or extend the deadline for completion of the conference. Such request shall state the reasons the acceleration or extension is sought and shall be served by the moving party upon the other parties and the Mediator. Objections to the request must be promptly communicated to the County and to the Mediator.

The County, with the concurrence of the designated Mediator, may grant the request by adjusting the time for completion of the conference.

**D. Recesses.** The Mediator may recess the mediation conference at any time and may set times for reconvening. If the Mediator determines the time and place where the conference is to reconvene before the conference is recessed, no further notice is required to persons present at the conference.

**E. Project Delay.** The mediated settlement conference that results from a construction contract dispute shall not be cause for the delay of the construction project.

### **RULE 4. DUTIES OF PARTIES AND OTHER PARTICIPANTS IN FORMAL DISPUTE RESOLUTION PROCESS**

#### **A. Attendance.**

1. All parties to the dispute must designate an official representative to attend the mediation.
2. "Attendance" means physical attendance, not by telephone or other electronic means. Any attendee representing a party must have authority from that party to bind it to any agreement reached as a result of the mediation.
3. Attorneys representing parties may attend the mediation, but are not required to do so.

4. Sureties and insurance company representatives are required to physically attend the mediation unless the Mediator and all of the other parties to the mediation excuse their attendance or consent to their attendance by telephone or other electronic means.

5. The parties who attend a duly scheduled mediation conference shall have the right to recover their share of the Mediator's compensation from any party or parties who fail to attend the conference without good cause.

**B. Finalizing Agreement.** If an agreement is reached in the conference, the terms of the agreement shall be confirmed in writing and signed by all parties.

**C. Payment of Mediation Fee:** Mediation Fees charged by the Mediator shall be paid in accordance with G.S. § 143-128(f1).

**D. Failure to Compensate Mediator.** Any party's failure to compensate the Mediators in accordance with G.S. § 143-128(f1) shall subject that party to a withholding by the County of said amount of money from the party's payment or any other moneys owed by that party to the County.

Should the County fail to compensate the Mediator, it shall hereby be subject to a civil cause of action from the Mediator for the County's portion of the Mediator's total fee as required by G.S. § 143-128(f1).

## **RULE 5. AUTHORITY AND DUTIES OF MEDIATORS**

### **A. Authority of Mediator.**

1. Control of Conference. The Mediator shall at all times be in control of the conference and the procedures to be followed.

2. Private Consultation. The Mediator may communicate privately with any participant or counsel prior to and during the conference. The fact that private communications have occurred with a participant shall be disclosed to all other participants at the beginning of the conference.

3. Scheduling the Conference. The Mediator shall make a good faith effort to schedule the conference at a time that is convenient with the participants, attorneys and Mediator. In the absence of agreement, the Mediator shall select the date for the conference.

4. Determining good cause for a party's failure to appear at a scheduled mediation conference.

### **B. Duties of Mediator.**

1. The Mediator shall define and describe the following at the beginning of the conference:

a. The process of mediation.

b. The difference between mediation and other forms of conflict resolution.

c. The costs of the mediated settlement conference.

d. That the mediated settlement conference is not a trial, the Mediator is not a judge, and the parties retain their legal rights if they do not reach settlement; however, the

Mediator will advise all parties that failure to appear at mediation without good cause may result in imposition of sanctions and may be asserted as a bar to lawsuits by claimants who have failed to exhaust this administrative remedy.

e. The circumstances under which the Mediator may meet and communicate privately with any of the parties or with any other person.

f. Whether and under what conditions communications with the Mediator will be held in confidence during the conference.

g. The inadmissibility of conduct and statements as provided by G.S. §7A-38.1(1).

h. The duties and responsibilities of the Mediator and the participants.

i. That any agreement reached will be reached by mutual consent.

2. Disclosure: The Mediator has a duty to be impartial and to advise all participants of any possible bias, prejudice or partiality.

3. Declaring Impasse: The Mediator may determine at any time during the mediation conference that an impasse exists and that the conference should end.

4. Reporting Results of Conference. The Mediator shall submit a written report to the County and the other parties within 10 days of the conference stating whether or not the parties reached an agreement. The Mediator's report shall indicate the absence of any party from the mediated settlement conference without permission or good cause.

5. Scheduling and Holding the Conference. It is the duty of the Mediator to schedule the conference and conduct it prior to the deadline of completion set by the rules. The Mediator shall strictly observe deadlines for completion of the conference unless said time limit is changed by agreement of the parties.

#### **RULE 6. COSTS AND COMPENSATION OF THE MEDIATOR**

The Parties shall compensate the Mediator for mediation services at the rate proposed by the Mediator and agreed to by the parties at the time the Mediator is selected. The Parties shall be jointly responsible for the Mediator's costs and expenses subject to Rule 4.C. above. Each Party is responsible for its own costs and expenses, including reasonable attorneys' fees, related to the Mediation.

#### **RULE 7. RULE MAKING**

These Rules may be amended by the County at any time. Amendments will not affect mediations where claims or requests for mediation have been filed at the time the amendment takes effect.

#### **RULE 8. DEFINITIONS**

**A.** "County" shall mean Orange County North Carolina.

**B.** "Project Designer" is that person or firm stipulated as project designer in the Contract Documents for the project.

Revised 01/24

**C.** “Claim” is a demand or assertion by a party seeking adjustment or interpretation of Contract terms, payment of money, extension of time or other relief with respect to the terms of the Contract. The term “Claim” also includes other disputes and matters in question between the parties to a Contract involved in the County’s building construction renovation and repair projects arising out of or relating to the Contract or the construction process. Claims must be initiated by a written notice. The responsibility to substantiate Claims shall rest with the party making the Claim.

**D.** “Good Cause” generally includes any circumstance beyond the control of a party, which prevents that party from meeting obligations. When good cause is asserted as an excuse for a party’s failure to appear at a mediation conference or to otherwise comply with the requirements of these Rules, the Mediator, in his or her sole discretion, will determine whether good cause exists to excuse the party’s failure to appear or otherwise comply with these rules.

**RULE 9. TIME LIMITS**

**A.** Any time limit provided for by these Rules may be waived or extended at the sole discretion of the County, if no Mediator has been selected, and at the discretion of the County with concurrence of the Mediator if a Mediator has been selected.

## **Chapter 12 Civil Rights.**

### **Sections 12-23 – 12-49 Reserved.**

## **AN ORDINANCE PROHIBITING DISCRIMINATION THROUGHOUT ORANGE COUNTY**

### **Sec. 12-50. - Title.**

This Ordinance shall be known and may be cited as the Orange County Non-Discrimination Ordinance.

### **Sec. 12-51. – Policy and Severability.**

(a) It is the policy of Orange County not to enter into a contract with any business, company, or firm that has discriminated in the solicitation, selection, hiring or treatment of vendors, suppliers, subcontractors or commercial customers against a Protected Class, or on the basis of any otherwise unlawful use of individual or personal characteristics regarding such vendor's, suppliers, commercial customers, employees, or owners in connection with a county contract or solicitation; provided that nothing in this non-discrimination policy shall prohibit or limit otherwise lawful efforts to remedy the effects of discrimination that has occurred or is occurring in the marketplace.

1. It is the policy of Orange County that every Orange County created contract and subcontract for goods or services shall contain a non-discrimination clause that prohibits discrimination as that term is defined herein.

(b) It is further the policy of Orange County that discrimination has no place in Orange County, North Carolina and it is the intent of this ordinance to provide uniform legal protection to individuals in all Protected Classes, making it unlawful for any person to discriminate in housing, public accommodations, and transportation.

(c) Should any provision of this Ordinance be found to be unconstitutional by a court of law such provision shall be severed from the remainder of the Ordinance and such action shall not affect the enforceability of the remaining provisions of the Ordinance.

### **Sec. 12-52. - Definitions.**

(a) *Discrimination* means any disadvantage, difference, or distinction in the solicitation, selection, hiring, service to, or treatment of a vendor, supplier, subcontractor, or customer on the basis of Protected Class status or on the basis of any otherwise unlawful use of personal or individual characteristics.

(b) *Housing* and *public accommodations* have the same common meaning as those terms are defined in the Orange County Civil Rights Ordinance.

(c) *Person* means any individual, business, or company, regardless of organizational structure,

providing for profit goods, facilities, services, accommodations, transportation, or access to the general public.

- (d) *Protected Class* means age (as defined in the Orange County Civil Rights Ordinance), race, ethnicity, color, national origin, religion, creed, sex, sexual orientation, gender, gender identity, gender expression, marital status, familial status, source of income, disability, political affiliation, veteran status, disabled veteran status.
- (e) *Public Accommodation* has the same meaning as that term is defined in the Orange County Civil Rights Ordinance except that for purposes of this Ordinance Public Accommodation includes:
  - 1. Transportation companies and transportation providers operating company-owned or privately-owned vehicles providing transportation to the general public; and
  - 2. Private residences providing short-term rentals to members of the general public. A short-term rental means the provision of a room, space, or residential unit that is suitable or intended for occupancy for dwelling, sleeping, or lodging purposes, for a period of fewer than 30 consecutive days, in exchange for a charge for the occupancy.

**Sec. 12-53. - Contractor bid requirements.**

- (a) All requests for bids or proposals issued for county contracts shall include a certification to be completed by the bidder or proposer in substantially the following form:

The undersigned bidder or proposer hereby certifies and agrees that the following information is correct:

- 1. In preparing its enclosed bid or proposal, the bidder or proposer has considered all bids and proposals submitted from qualified, potential subcontractors and suppliers, and has not engaged in discrimination as defined in Section 12-52 of the Orange County Non-discrimination Ordinance.
- 2. Without limiting any other remedies that Orange County may have for a false certification, it is understood and agreed that, if this certification is false, such false certification will constitute grounds for Orange County to reject the bid or proposal submitted with this certification, and terminate any contract awarded based on such bid or proposal. It shall also subject the bidder or proposer to disqualification from participating in county contracts or bid processes for up to two years.
- 3. As a condition of contracting with Orange County, the bidder or proposer agrees to promptly provide to Orange County all information and documentation that may be requested by Orange County from time to time regarding the solicitation and selection of suppliers and subcontractors in connection with this solicitation process. Failure to maintain or failure to provide such information constitutes grounds for Orange County to reject the bid or proposal and to terminate, without penalty to Orange County, any contract awarded on such bid or proposal. All such information and documentation shall be maintained for a period of three years after the expiration of the contract.
- 4. As part of its bid or proposal, the bidder or proposer shall provide to Orange County

a list of all instances within the past ten years where a complaint was filed or pending against bidder or proposer in a legal or administrative proceeding alleging that bidder or proposer discriminated against its subcontractors, vendors, suppliers, or commercial customers, and a description of the status or resolution of that complaint, including any remedial action taken.

5. As a condition of submitting a bid or proposal to Orange County the bidder or proposer agrees to comply with the Orange County Non-discrimination Ordinance. Falsification of this certification shall constitute a violation of the Orange County Non-Discrimination Ordinance and shall be grounds for rejection of the bid or proposal or termination, without fault to Orange County, of a contract.
6. As a condition of submitting a bid or proposal to Orange County the bidder or proposer agrees that Orange County may consider the information submitted as part of this certification in its determination of the responsibility of the bidder or proposer. The bidder or proposer, as the case may be, waives the right to challenge the rejection of a bid or proposal when such rejection is based, in its entirety, on information contained in this certification.

**Sec. 12-54. - Prohibited acts.**

- (a) It shall be unlawful for any person to deny any person the full and equal enjoyment of the goods, services, facilities, privileges, advantages, and accommodations of a place of public accommodation on the basis of Protected Class status or on the basis of any otherwise unlawful use of individual or personal characteristics.
- (b) It shall be unlawful for any person to make, print, circulate, post, mail or otherwise cause to be published a statement, advertisement, or sign which indicates that the full and equal enjoyment of the transportation, access, goods, services, facilities, privileges, advantages, and accommodations of a place of public accommodation will be refused, withheld from, or denied any person on the basis of Protected Class status or on the basis of any otherwise unlawful use of individual or personal characteristics, or that any person's patronage of or presence at a place of public accommodation is objectionable, unwelcome, unacceptable, or undesirable on the basis of Protected Class status or on the basis of any otherwise unlawful use of individual or personal characteristics; provided, however, this section does not apply to a private club or other establishment not, in fact, open to the public.
- (c) It shall be unlawful for any person to intentionally or knowingly:
  1. Perform or attempt to perform any act which directly or indirectly results in an individual's bodily injury or property damage where such act is directed at an individual or a group of individuals because of that person's or that group's perceived or actual Protected Class status or on the basis of any otherwise unlawful use of individual or personal characteristics.
  2. Solicit, encourage, compensate, assist, or conspire with another to perform or attempt to perform any act which directly or indirectly results in an individual's bodily injury or property damage where such act is directed at an individual or a group of individuals because of that person's or that group's perceived or actual Protected Class status or on the basis of any otherwise unlawful use of individual or personal characteristics.

- (d) No person shall be found to have violated this Ordinance solely on the basis of the content of any speech or communication used by such person.

**Sec. 12-55. Exemptions.**

- (a) All applicable exemptions found in Section 12-11 of the Orange County Civil Rights Ordinance related to housing shall apply to alleged violations of Section 12-54 of this Ordinance.

**Sec. 12-56. Investigation, Enforcement, and Remedy.**

- (a) Sections 12-16 through and including 12-21 of the Orange County Civil Rights Ordinance shall be followed and adhered to during the investigation of any alleged violation of this Ordinance. Any remedies available through said sections of the Orange County Civil Rights Ordinance shall be available hereunder.

## ORANGE COUNTY NONDISCRIMINATION CERTIFICATION

The undersigned bidder or proposer hereby certifies and agrees that the following information is correct:

1. In preparing its enclosed bid or proposal, the undersigned bidder or proposer has considered all bids and proposals submitted from qualified, potential subcontractors and suppliers, and has not engaged in discrimination as defined in Section 12-52 of the Orange County Non-discrimination Ordinance.
2. Without limiting any other remedies that Orange County may have for a false certification, it is understood and agreed that, if this certification is false, such false certification will constitute grounds for Orange County to reject the bid or proposal submitted with this certification, and terminate any contract awarded based on such bid or proposal. It shall also subject the bidder or proposer to disqualification from participating in county contracts or bid processes for up to two years.
3. As a condition of contracting with Orange County, the undersigned bidder or proposer agrees to promptly provide to Orange County all information and documentation that may be requested by Orange County from time to time regarding the solicitation and selection of suppliers and subcontractors in connection with this solicitation process. Failure to maintain or failure to provide such information constitutes grounds for Orange County to reject the bid or proposal and to terminate, without penalty to Orange County, any contract awarded on such bid or proposal. All such information and documentation shall be maintained for a period of three years after the expiration of the contract.
4. As part of its bid or proposal, the undersigned bidder or proposer shall provide to Orange County a list of all instances within the past ten years where a complaint was filed or pending against bidder or proposer in a legal or administrative proceeding alleging that bidder or proposer discriminated against its subcontractors, vendors, suppliers, or commercial customers, and a description of the status or resolution of that complaint, including any remedial action taken.
5. As a condition of submitting a bid or proposal to Orange County the undersigned bidder or proposer agrees to comply with the Orange County Non-discrimination Ordinance. Falsification of this certification shall constitute a violation of the Orange

County Non-Discrimination Ordinance and shall be grounds for rejection of the bid or proposal or termination of an existing contract, without fault or further obligation to Orange County.

6. As a condition of submitting a bid or proposal to Orange County the undersigned bidder or proposer agrees that Orange County may consider the information submitted as part of this certification in its determination of the responsibility of the undersigned bidder or proposer. The undersigned bidder or proposer, as the case may be, waives the right to challenge the rejection of a bid or proposal when such rejection is based, in its entirety, on information submitted as part of this certification.

The bidder or proposer certifies the undersigned has full authority to sign on its behalf.

By: \_\_\_\_\_

\_\_\_\_\_  
Printed Name and Title

On behalf of \_\_\_\_\_

\_\_\_\_\_  
Company or Corporate name

Date: \_\_\_\_\_

## MINORITY BUSINESSES PARTICIPATION REQUIREMENTS

Orange County has established a verifiable ten percent (10%) minority business participation goal for the total monetary value of this project. Verifiable goal means that the awarding authority has adopted written guidelines specifying the actions that the prime contractor must take to ensure a good faith effort in the recruitment and selection of minority businesses for participation in contracts awarded; the required actions must be documented in writing by the contractor to the appropriate awarding authority. These guidelines are published to accomplish that end.

### DEFINITIONS:

Minority - a person who is a citizen or lawful permanent resident of the United States and who is:

- a. Black, that is, a person having origins in any of the black racial groups in Africa;
- b. Hispanic, that is, a person of Spanish or Portuguese culture with origins in Mexico, South or Central America, or the Caribbean Islands, regardless of race;
- c. Asian American, that is, a person having origins in any of the original peoples of the Far East, Southeast Asia and Asia, the Indian subcontinent, the Pacific Islands;
- d. American Indian or Alaskan Native, that is, a person having origins in any of the original peoples of North America; or
- e. Female.

### Socially and Economically Disadvantaged Individual:

Socially disadvantaged individuals are those who have been subjected to racial or ethnic prejudice or cultural bias because of their identity as a member of a group without regard to their individual qualities. Economically disadvantaged individuals are those socially disadvantaged individuals whose ability to compete in the free enterprise system has been impaired due to diminished capital and credit opportunities as compared to others in the same business area who are not socially disadvantaged.

Minority Business - means a business:

- a. In which at least fifty-one percent (51%) is owned by one or more minority persons, or in the case of a corporation, in which at least fifty-one percent (51%) of the stock is owned by one or more minority persons; and
- b. Of which the management and daily business operations are controlled by one or more of the minority persons who own it; and
- c. Is certified in one of the MWBE categories as defined by the NC Department of Administration/Historically Underutilized Business (HUB) and the NC Department of Transportation/Disadvantaged Business Enterprise (DBE).

### Bidder Responsibilities:

Under the single prime contract system, the prime contractor will:

- a. Attend the scheduled Prebid conference.
- b. Identify or determine those work areas of a contract where MBEs may have an interest in performing contract work.

- c. At least ten (10) days prior to the scheduled day of bid opening, notify certified MBEs of potential contracting opportunities listed in the proposal. The notification will include the following:
  - 1. A description of the work for which the bid is being solicited.
  - 2. The date, time and location where bids are to be submitted.
  - 3. The name of the individual within the agency/institution who will be available to answer questions about the project.
  - 4. Where bid documents may be reviewed.
  - 5. Any special requirements that may exist, such as insurance, licenses, bonds and financial arrangements.
- d. During the bidding process, comply with the contractor(s) requirements listed in the proposal for minority participation.
- e. Submit with the bid a description of that portion of the work to be executed by MBEs expressed as a percentage of the total price.
- f. Identify the MBEs the bidder intends to use on the contract, along with the dollar amount of the work to be performed by each minority business.
- g. Submit an affidavit that details the good faith efforts taken to procure minority business participation.
- h. Upon being named the apparent low bidder, the bidder shall provide the necessary documentation as listed in the contract documents. Failure to comply with procedural requirements as defined in contract documents may render that bid as non-responsive and may result in rejection of the bid and award to the next lowest responsible and responsive bidder.
- i. Upon being named apparent low bidder, the bidder shall provide an affidavit that lists the proportion of the work to be performed by MBEs. **If the MBEs do not account for ten percent (10%) of the contract price, the bidder must submit an affidavit that verifies the bidder's good faith efforts by certifying that it has undertaken at least five of the following ten (10) steps:**
  - 1. Contacted minority businesses that reasonably could have been expected to submit a quote and that were known to the contract or available on these State or local government-maintained lists at least ten (10) days before the bid or proposal date and notifying them of the nature and scope of the work to be performed.
  - 2. Made the construction plans, specifications, and requirements available for review by prospective minority businesses, or providing these documents to them at least ten (10) days before the bid proposals are due.
  - 3. Broke down or combined elements of work into economically feasible units to facilitate minority participation.
  - 4. Worked with minority trade, community, or contractor organizations identified by the Office of Historical Underutilized Businesses and included in the bid documents that provided assistance in recruitment of minority businesses.
  - 5. Attended any prebid meetings scheduled by the public owner.

6. Provided assistance in getting required bonding or insurance or providing alternatives to bonding or insurance for subcontractors.
  7. Negotiated in good faith with interested minority businesses and did not reject them as unqualified without sound reasons based on their capabilities. Any rejection of a minority business based on lack of qualifications should have the reasons documented in writing.
  8. Provided assistance to an otherwise qualified minority business in need of equipment, loan capital, lines of credit, or joint pay agreements to secure loans, supplies, or letters of credit, including waiving credit that is ordinarily required. Assisted minority businesses in obtaining the same unit pricing with the bidder's suppliers in order to help the minority businesses in establishing credit.
  9. Negotiated joint venture and partnership arrangements with minority businesses in order to increase opportunities for minority business participation on a public construction or repair project when possible.
  10. Provide quick pay agreements and policies to enable minority contractors and suppliers to meet cash-flow demands.
- j. During the construction of the project, if it becomes necessary to replace an MBE subcontractor, advise the owner of the circumstances involved.
- k. If, during the construction of a project, additional subcontracting opportunities become available, make a good faith effort to solicit subbids from MBEs.

# State of North Carolina AFFIDAVIT A – Listing of Good Faith Efforts

County of \_\_\_\_\_

(Name of Bidder)

Affidavit of \_\_\_\_\_

I have made a good faith effort to comply under the following areas checked:

**Bidders must earn at least 50 points from the good faith efforts listed for their bid to be considered responsive.** (1 NC Administrative Code 30 I.0101)

- 1 – (10 pts)** Contacted minority businesses that reasonably could have been expected to submit a quote and that were known to the contractor, or available on State or local government maintained lists, at least 10 days before the bid date and notified them of the nature and scope of the work to be performed.
- 2 --(10 pts)** Made the construction plans, specifications and requirements available for review by prospective minority businesses, or providing these documents to them at least 10 days before the bids are due.
- 3 – (15 pts)** Broken down or combined elements of work into economically feasible units to facilitate minority participation.
- 4 – (10 pts)** Worked with minority trade, community, or contractor organizations identified by the Office of Historically Underutilized Businesses and included in the bid documents that provide assistance in recruitment of minority businesses.
- 5 – (10 pts)** Attended prebid meetings scheduled by the public owner.
- 6 – (20 pts)** Provided assistance in getting required bonding or insurance or provided alternatives to bonding or insurance for subcontractors.
- 7 – (15 pts)** Negotiated in good faith with interested minority businesses and did not reject them as unqualified without sound reasons based on their capabilities. Any rejection of a minority business based on lack of qualification should have the reasons documented in writing.
- 8 – (25 pts)** Provided assistance to an otherwise qualified minority business in need of equipment, loan capital, lines of credit, or joint pay agreements to secure loans, supplies, or letters of credit, including waiving credit that is ordinarily required. Assisted minority businesses in obtaining the same unit pricing with the bidder's suppliers in order to help minority businesses in establishing credit.
- 9 – (20 pts)** Negotiated joint venture and partnership arrangements with minority businesses in order to increase opportunities for minority business participation on a public construction or repair project when possible.
- 10 - (20 pts)** Provided quick pay agreements and policies to enable minority contractors and suppliers to meet cash-flow demands.

The undersigned, if apparent low bidder, will enter into a formal agreement with the firms listed in the Identification of Minority Business Participation schedule conditional upon scope of contract to be executed with the Owner. Substitution of contractors must be in accordance with GS143-128.2(d) Failure to abide by this statutory provision will constitute a breach of the contract.

The undersigned hereby certifies that he or she has read the terms of the minority business commitment and is authorized to bind the bidder to the commitment herein set forth.

Date: \_\_\_\_\_ Name of Authorized Officer: \_\_\_\_\_

Signature: \_\_\_\_\_

Title: \_\_\_\_\_

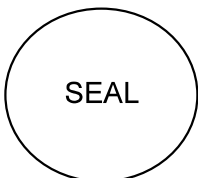

State of \_\_\_\_\_, County of \_\_\_\_\_

Subscribed and sworn to before me this \_\_\_\_\_ day of \_\_\_\_\_ 20\_\_\_\_

Notary Public \_\_\_\_\_

My commission expires \_\_\_\_\_

# State of North Carolina --AFFIDAVIT B-- Intent to Perform Contract with Own Workforce.

County of \_\_\_\_\_

Affidavit of \_\_\_\_\_  
(Name of Bidder)

I hereby certify that it is our intent to perform 100% of the work required for the \_\_\_\_\_ contract.  
(Name of Project)

In making this certification, the Bidder states that the Bidder does not customarily subcontract elements of this type project, and normally performs and has the capability to perform and will perform all elements of the work on this project with his/her own current work forces; and

The Bidder agrees to provide any additional information or documentation requested by the owner in support of the above statement. The Bidder agrees to make a Good Faith Effort to utilize minority suppliers where possible.

The undersigned hereby certifies that he or she has read this certification and is authorized to bind the Bidder to the commitments herein contained.

Date: \_\_\_\_\_ Name of Authorized Officer: \_\_\_\_\_

Signature: \_\_\_\_\_

Title: \_\_\_\_\_

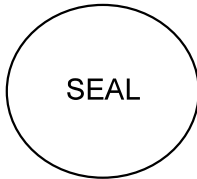

State of \_\_\_\_\_, County of \_\_\_\_\_

Subscribed and sworn to before me this \_\_\_\_\_ day of \_\_\_\_\_ 20\_\_

Notary Public \_\_\_\_\_

My commission expires \_\_\_\_\_

# State of North Carolina - AFFIDAVIT C - Portion of the Work to be Performed by HUB Certified/Minority Businesses

County of \_\_\_\_\_

**(Note this form is to be submitted only by the apparent lowest responsible, responsive bidder.)**

If the portion of the work to be executed by HUB certified/minority businesses as defined in GS143-128.2(g) and 128.4(a),(b),(e) is equal to or greater than 10% of the bidders total contract price, then the bidder must complete this affidavit.  
 This affidavit shall be provided by the apparent lowest responsible, responsive bidder within **72 hours** after notification of being low bidder.

Affidavit of \_\_\_\_\_ I do hereby certify that on the \_\_\_\_\_  
 (Name of Bidder)

\_\_\_\_\_ (Project Name)  
 Project ID# \_\_\_\_\_ Amount of Bid \$ \_\_\_\_\_

I will expend a minimum of \_\_\_\_\_% of the total dollar amount of the contract with minority business enterprises. Minority businesses will be employed as construction subcontractors, vendors, suppliers or providers of professional services. Such work will be subcontracted to the following firms listed below. Attach additional sheets if required

Name and Phone Number	*Minority Category	**HUB Certified Y/N	Work Description	Dollar Value

\*Minority categories: Black, African American (**B**), Hispanic (**H**), Asian American (**A**) American Indian (**I**), Female (**F**) Socially and Economically Disadvantaged (**D**)

**\*\* HUB Certification with the state HUB Office required to be counted toward state participation goals.**

Pursuant to GS143-128.2(d), the undersigned will enter into a formal agreement with Minority Firms for work listed in this schedule conditional upon execution of a contract with the Owner. Failure to fulfill this commitment may constitute a breach of the contract.

The undersigned hereby certifies that he or she has read the terms of this commitment and is authorized to bind the bidder to the commitment herein set forth.

Date: \_\_\_\_\_ Name of Authorized Officer: \_\_\_\_\_

Signature: \_\_\_\_\_

Title: \_\_\_\_\_

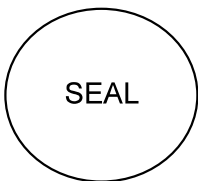

State of \_\_\_\_\_, County of \_\_\_\_\_

Subscribed and sworn to before me this \_\_\_\_\_ day of \_\_\_\_\_ 20\_\_\_\_

Notary Public \_\_\_\_\_

My commission expires \_\_\_\_\_

# State of North Carolina AFFIDAVIT D – Good Faith Efforts

County of \_\_\_\_\_

**(Note this form is to be submitted only by the apparent lowest responsible, responsive bidder.)**

If the goal of 10% participation by HUB Certified/ minority business **is not** achieved, the Bidder shall provide the following documentation to the Owner of his good faith efforts:

Affidavit of \_\_\_\_\_ I do hereby certify that on the \_\_\_\_\_  
(Name of Bidder)

Project ID# \_\_\_\_\_ (Project Name) Amount of Bid \$ \_\_\_\_\_

I will expend a minimum of \_\_\_\_\_% of the total dollar amount of the contract with HUB certified/ minority business enterprises. Minority businesses will be employed as construction subcontractors, vendors, suppliers or providers of professional services. Such work will be subcontracted to the following firms listed below. (Attach additional sheets if required)

Name and Phone Number	*Minority Category	**HUB Certified Y/N	Work Description	Dollar Value

\*Minority categories: Black, African American (**B**), Hispanic (**H**), Asian American (**A**) American Indian (**I**), Female (**F**) Socially and Economically Disadvantaged (**D**)

**\*\* HUB Certification with the state HUB Office required to be counted toward state participation goals.**

Examples of documentation that may be required to demonstrate the Bidder's good faith efforts to meet the goals set forth in these provisions include, but are not necessarily limited to, the following:

- A. Copies of solicitations for quotes to at least three (3) minority business firms from the source list provided by the State for each subcontract to be let under this contract (if 3 or more firms are shown on the source list). Each solicitation shall contain a specific description of the work to be subcontracted, location where bid documents can be reviewed, representative of the Prime Bidder to contact, and location, date and time when quotes must be received.
- B. Copies of quotes or responses received from each firm responding to the solicitation.
- C. A telephone log of follow-up calls to each firm sent a solicitation.
- D. For subcontracts where a minority business firm is not considered the lowest responsible sub-bidder, copies of quotes received from all firms submitting quotes for that particular subcontract.
- E. Documentation of any contacts or correspondence to minority business, community, or contractor organizations in an attempt to meet the goal.
- F. Copy of pre-bid roster
- G. Letter documenting efforts to provide assistance in obtaining required bonding or insurance for minority business.
- H. Letter detailing reasons for rejection of minority business due to lack of qualification.
- I. Letter documenting proposed assistance offered to minority business in need of equipment, loan capital, lines of credit, or joint pay agreements to secure loans, supplies, or letter of credit, including waiving credit that is ordinarily required.

Failure to provide the documentation as listed in these provisions may result in rejection of the bid and award to the next lowest responsible and responsive bidder.

Pursuant to GS143-128.2(d), the undersigned will enter into a formal agreement with Minority Firms for work listed in this schedule conditional upon execution of a contract with the Owner. Failure to fulfill this commitment may constitute a breach of the contract.

The undersigned hereby certifies that he or she has read the terms of this commitment and is authorized to bind the bidder to the commitment herein set forth.

Date: \_\_\_\_\_ Name of Authorized Officer: \_\_\_\_\_

Signature: \_\_\_\_\_

Title: \_\_\_\_\_

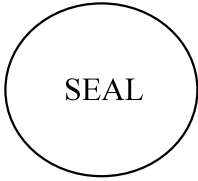

State of \_\_\_\_\_, County of \_\_\_\_\_

Subscribed and sworn to before me this \_\_\_\_\_ day of \_\_\_\_\_ 20\_\_\_\_

Notary Public \_\_\_\_\_

My commission expires \_\_\_\_\_

**Supplemental Vendor Information: HISTORICALLY UNDERUTILIZED BUSINESSES**

**Vendor Name:** \_\_\_\_\_ **Date:** \_\_\_\_\_

Per G.S. 143-128.4, Historically Underutilized Businesses (HUBs) consist of minority, women and disabled business firms that are at least fifty-one percent (51%) owned and operated by an individual(s) who are members of the following groups: Black, Hispanic, Asian American, American Indian, Female, Disabled, Disadvantaged.

The Vendor shall respond to question No 1 and No 2 below.

1) Is Vendor a Historically Underutilized Business?  **Yes**  **No**

If yes, please select from the following:

- | <b>Ethnicity:</b>                               | <b>Gender</b>                          | <b>Disabled</b>                     |
|---|--|-------------------------------------|
| <input type="checkbox"/> <b>Black</b>           | <input type="checkbox"/> <b>Male</b>   | <input type="checkbox"/> <b>Yes</b> |
| <input type="checkbox"/> <b>Hispanic</b>        | <input type="checkbox"/> <b>Female</b> | <input type="checkbox"/> <b>No</b>  |
| <input type="checkbox"/> <b>Asian American</b>  |  |                                     |
| <input type="checkbox"/> <b>American Indian</b> |  |                                     |

2) Is Vendor Certified with North Carolina as a Historically Underutilized Business?  **Yes**  **No**

If so, state HUB classification: \_\_\_\_\_

Any questions concerning NC HUB certification, contact the [North Carolina Office of Historically Underutilized Businesses](#) at (919) 807-2330.



## Contractor's Safety Record Information

The Contractor's safety record shall be reviewed and evaluated in addition to other quality and performance criteria as part of bid evaluation process. Failure to provide the requested information and documentation may result in rejection of your bid as non-responsive.

Accordingly, all bidders must submit the following information regarding their safety record.

The following definitions shall apply to this section:

"DART incident rate" – Acronym for "Days Away, Restrictions and Transfers". The DART incident rate may be used to show the relative level of injuries and illnesses within a firm compared to the industry. It is based only on those injuries and illnesses severe enough to warrant "Days Away, Restrictions and Transfers". The DART incident rate is calculated using OSHA's Form 300 and the following formula:

$$\frac{((\text{Number of entries in column H (days away from work)} + \text{column I (job transfer or restriction)}) \times 200,000) / (\text{Number of hours worked by all employees})}{\text{Number of hours worked by all employees}} = \text{DART Incident rate.}$$

"EMR" – Acronym for "Experience Modification Rate," is an indicator of a contractor's past safety performance, widely used by the insurance industry as an equitable means of determining premiums for workers' compensation insurance. The rating system considers the average workers' compensation losses for a given firm's type of work and amount of payroll and predicts the dollar amount of expected losses to be paid by that employer in a designated rating period, usually three years. The rating is based on comparison of firms doing similar types of work, and the employer is rated against the average expected performance in each work classification. Losses incurred by the employer for the rating period are then compared to the expected losses to develop an experience rating.

"OSHA" – Acronym for the Federal Occupational Health and Safety Administration. The term "OSHA" as used in this Policy also refers to any state or local agency having jurisdictional authorization to enforce worker safety requirements and assess fines or warnings for violation of worker safety standards.

1. OSHA DART Incident Rate. Provide the bidder's DART Incident Rate calculated from OSHA's Form 300 for the last three years and the other required information shown in the example table below. *The bidder must attach all supporting documentation and calculations including certified OSHA forms.*

YEAR	CONTRACTOR DART INCIDENT RATE	INDUSTRY DART INCIDENT RATE	INDUSTRY FIELD AND CODE

2. Experience Modification Rate (EMR). Provide the bidder's most recent Experience Modification Rate (EMR) based on insurance claims history. *The bidder must provide the source of the EMR information and contact information of insurer entity providing the EMR.*

YEAR	CONTRACTOR EMR	INDUSTRY FIELD AND CODE	NAME AND CONTACT INFO FOR EMR INFORMATION

3. Answer the following OSHA Specific Questions:

(a) Within the last 2 years, has the bidder received any citations classified by OSHA as being (1) serious, (2) willful and/or (3) repeat violations where your company operates?

Yes \_\_\_\_\_ No \_\_\_\_\_

If yes, attach a copy of each such citation and violation.

(b) Has the bidder experienced any work-related fatalities within the last five years?

Yes \_\_\_\_\_ No \_\_\_\_\_

(c) Has the bidder had any citations issued by OSHA as a result of work related fatalities within the past 5 years?

Yes \_\_\_\_\_ No \_\_\_\_\_

(d) Is the bidder under investigation for any work-related fatalities?

Yes \_\_\_\_\_ No \_\_\_\_\_

(e) If your answer is “yes” to 3(b), (c) or (d), provide a copy of the citation(s), list of number(s) of fatalities and documented explanation of the fatality.

4. Safety Plan:

(a) Does the company have a written safety program that includes responsibility for all aspects of safety management?

Yes \_\_\_\_\_ No \_\_\_\_\_

(b) Does the company have a written plan for safety training of new employees and ongoing training of existing employees?

Yes \_\_\_\_\_ No \_\_\_\_\_

(c) Does the company have documented evidence of safety training that they have conducted?

Yes \_\_\_\_\_ No \_\_\_\_\_

(d) If the company has employees with limited English ability, does the company have a written plan for ensuring that their employees understand the training they are being given?

Yes \_\_\_\_\_ No \_\_\_\_\_

(e) Do all supervisors have an appropriate documented level of OSHA training (e.g., a minimum of 30 hour OSHA construction safety training)?

Yes \_\_\_\_\_ No \_\_\_\_\_

(f) Do employees have documented basic OSHA 10 hour construction safety training?

Yes \_\_\_\_\_ No \_\_\_\_\_

(g) Does the company have a documented Hazard Communication Program?

Yes \_\_\_\_\_ No \_\_\_\_\_

5. Required Written Explanation of Safety Record. If the bidder has any of the following: (a) DART incident rate greater than its industry average, (b) an EMR greater than 1.0, (c) answered “yes” to any of the OSHA Specific Question above, or (d) answered “no” to any of the Safety Plan questions, the bidder shall provide the County, in its bid, a detailed written explanation of its safety record and the reasons why such safety history is NOT representative of its future performance and what specific actions it has taken to improve its overall safety record. Failure to provide a written explanation of its safety record pursuant to this paragraph may be deemed as non-responsive by the County.

## Orange County Minimum Insurance Coverage Requirements

Note: An Exception or Waiver of Minimum Coverage may only be granted at the discretion and approval of Risk Management based on assessment of risk posed to the county.

Coverage	Low Risk Profile	Standard Risk Profile	High Risk Profile	Specialty	Encroachment	Premises Lease
<b>Commercial General Liability</b>	\$1,000,000/\$2,000,000 Per accident	\$1,000,000/\$2,000,000	\$1,000,000/\$2,000,000	\$1,000,000*	\$1,000,000	\$1,000,000
Products/Completed Operation Explosion, Collapse & Underground (XCU)	As above	As Above If any, Limit to be determined.	As above If any, TBD.	As Above If any, TBD.		
<b>Automobile Liability</b>	\$1,000,000 (CSL) Per occurrence	\$1,000,000*	\$1,000,000*	\$1,000,000*	N/A	N/A
<b>**Workers' Compensation</b>	Statutory	Statutory	Statutory	Statutory	N/A	Statutory
<b>**Employer's Liability</b>	100/500/100	500/500/500*	500/500/500	500/500/500*	N/A	100/500/100
<b>** Waiver of Subrogation on WC</b>	Required if available	Required if available	Required	Required	N/A	N/A
<b>Umbrella Liability</b>	\$1,000,000	\$2,000,000	\$2,000,000+	\$9,000,000+	N/A	N/A
<b>Professional Liability</b> <i>may</i> be required on a risk profile depending on nature of services provided by contract. Coverage required for professional service such as accountant, attorney, architect, design, engineering, health care and most consultants.	\$1,000,000 per occurrence	\$1,000,000	TBD	TBD	N/A	N/A
<b>Sexual Misconduct (Sexual Abuse/Molestation)</b> <i>may</i> be required for contractors working directly one-on-one with children and elderly or in overnight sheltering capacities.	\$1,000,000/\$2,000,000	\$1,000,000/\$2,000,000	TBD	TBD	N/A	TBD
<b>Cyber Liability</b> <i>may</i> be required for contractors having access to personal identifying information, and/or computer networks.	\$1,000,000/\$2,000,000	TBD	TBD	TBD	N/A	
<b>Environmental/Pollution Liability</b> required if demolition, use of	N/A	\$1,000,000	\$1,000,000+*	\$1,000,000+*	N/A	N/A

## Orange County Minimum Insurance Coverage Requirements

Note: An Exception or Waiver of Minimum Coverage may only be granted at the discretion and approval of Risk Management based on assessment of risk posed to the county.

hazardous material or environmentally sensitive						
<b>Fidelity Bond</b> (loss of money or other property due to dishonest acts). Only for contracts such as Banking, Janitorial, Fundraising, TPA's and similar, ETA	TBD	Amount depends on exposure to loss	TBD	TBD	N/A	N/A
<b>Other Coverage</b> As required	TBD	TBD	TBD	TBD	N/A	N/A
<b>Bid, Performance &amp; Payment Bonds</b>	TBD	TBD	TBD	TBD	N/A	N/A

\*A combination of Umbrella/Excess and primary limit may be used to provide coverage for the amount shown.

\*\* Workers' Compensation is required if the contractor/vendor has employees. Owner Waiver is acceptable for a Sole Proprietor.

C:\Users\frankis.winn\Desktop\Timber Drive Elementary School\CIVIL Template (COPY THIS)\Current Drawings\XX-XXX\_S.dwg, 7/18/2025 12:50:22 PM, frankis.winn, DWG To PDF.pc3

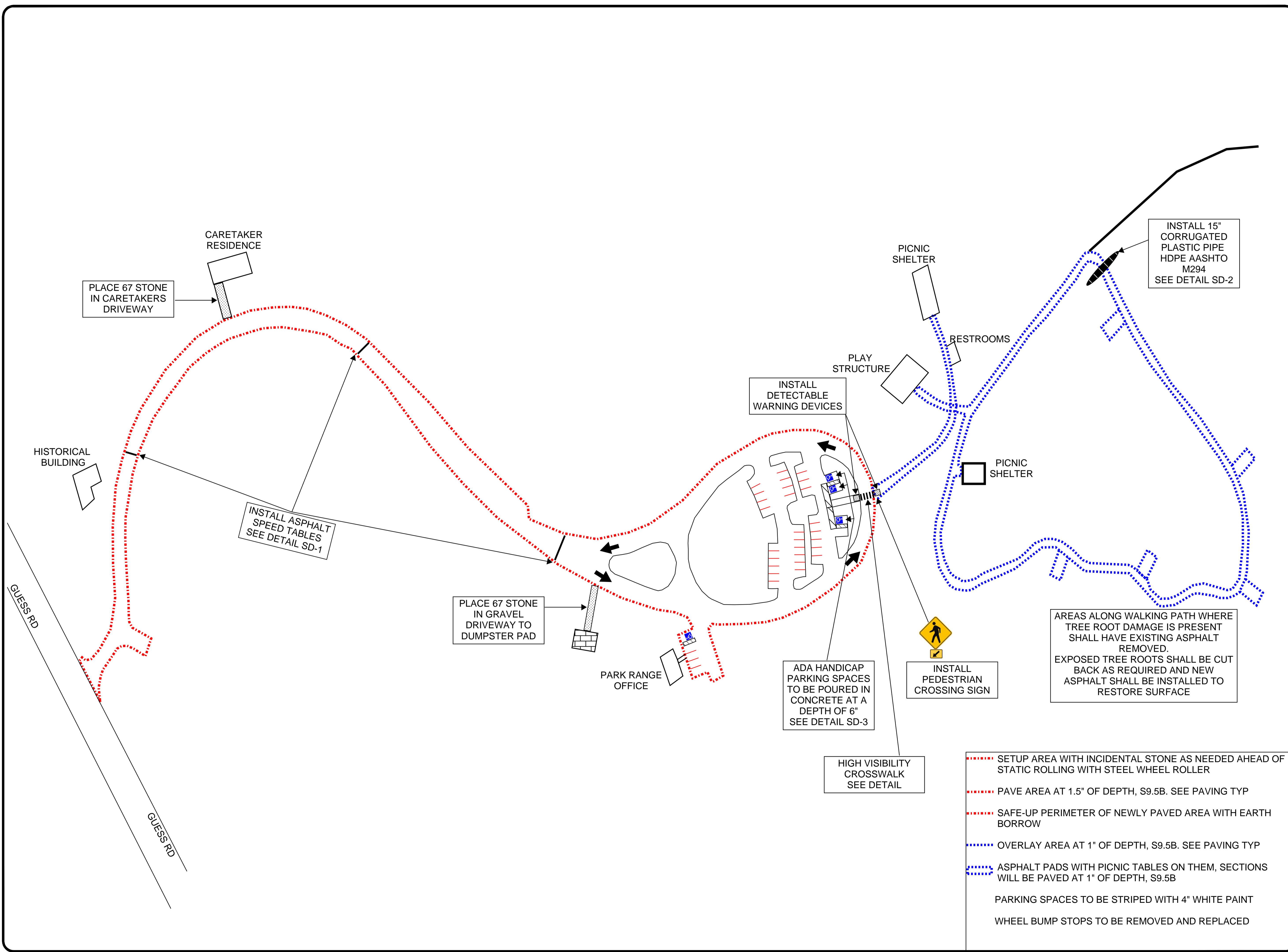

- SETUP AREA WITH INCIDENTAL STONE AS NEEDED AHEAD OF STATIC ROLLING WITH STEEL WHEEL ROLLER
- PAVE AREA AT 1.5" OF DEPTH, S9.5B. SEE PAVING TYP
- SAFE-UP PERIMETER OF NEWLY PAVED AREA WITH EARTH BORROW
- OVERLAY AREA AT 1" OF DEPTH, S9.5B. SEE PAVING TYP
- ASPHALT PADS WITH PICNIC TABLES ON THEM, SECTIONS WILL BE PAVED AT 1" OF DEPTH, S9.5B
- PARKING SPACES TO BE STRIPED WITH 4" WHITE PAINT
- WHEEL BUMP STOPS TO BE REMOVED AND REPLACED

NO.	REVISIONS	DATE	BY
7			
6			
5			
4			
3			
2			
1			

COPYRIGHT © 2025  
ALL RIGHTS RESERVED  
ENGINEERING SERVICES  
DRAWING ALTERATION  
THIS DRAWING IS THE PROPERTY OF SUMMIT DESIGN AND ENGINEERING SERVICES. IT IS TO BE USED ONLY FOR THE PROJECT AND SITE SPECIFICALLY IDENTIFIED IN THE TITLE BLOCK. ANY REUSE OR MODIFICATION OF THIS DRAWING WITHOUT THE WRITTEN PERMISSION OF SUMMIT DESIGN AND ENGINEERING SERVICES IS STRICTLY PROHIBITED.

**Randall Moore**  
PROJECT MANAGER  
RM/RANDALL.MOORE@SUMMITDE.COM

**DRAWN BY**  
RM/RANDALL.MOORE@SUMMITDE.COM

FIRST ISSUE DATE  
2/18/2026



**SUMMIT**  
DESIGN AND ENGINEERING SERVICES

State License #: C-5176  
301 Executive Court  
Raleigh, NC 27603  
Phone: (919) 732-5853 Fax: (919) 732-6676  
www.summitde.com

**LITTLE RIVER REGIONAL PARK  
REPAVING PROJECT**  
301 LITTLE RIVER PARK WAY,  
ROUGE MOUNT, NC 27572

Owner:  
Orange County Department of Environment, Agriculture, Parks,  
and Recreation  
Durham County Parks and Recreation

PROJECT NO.  
25-0022.225

SHEET NO.  
S-1

DETAIL NO.

C:\Users\frankis.winn\Desktop\Timber Drive Elementary School\Civil Template (COPY THIS)\Current Drawings\XX-XXX\_S.dwg, 7/18/2025 12:50:22 PM, frankis.winn, DWG To PDF.pc3

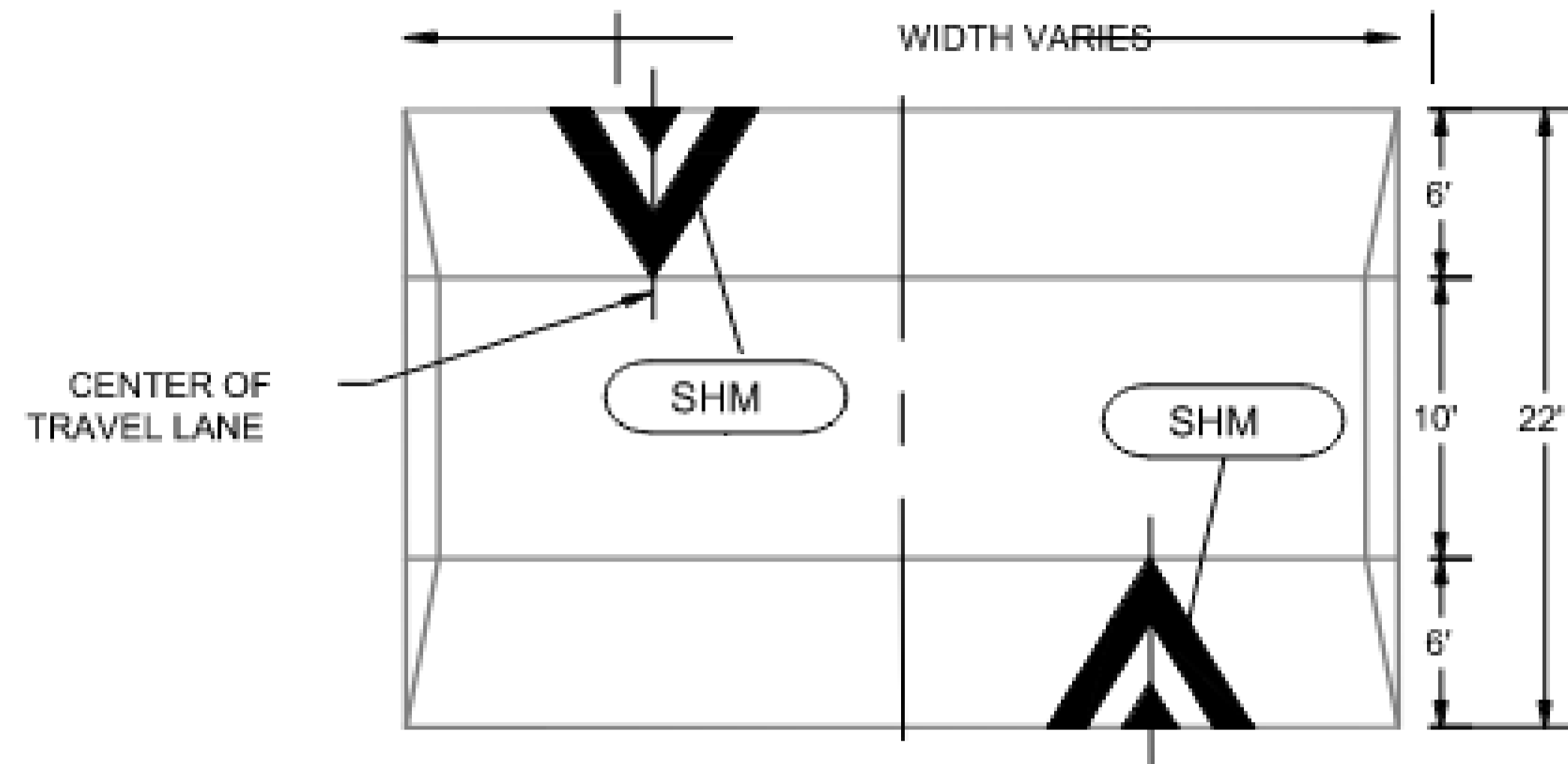

SPEED TABLE STRIPING LAYOUT

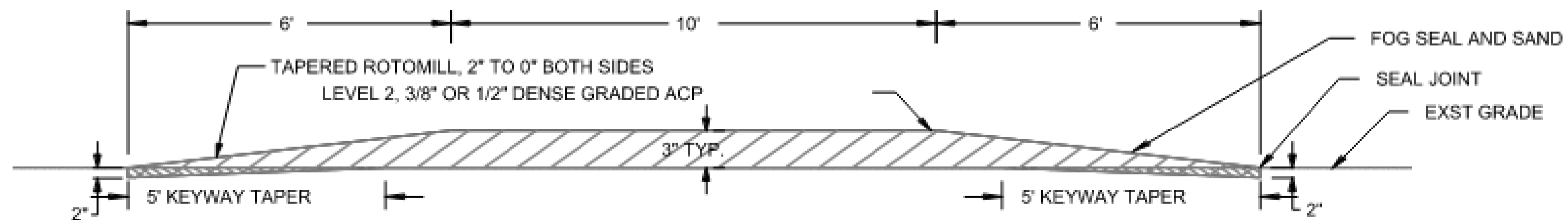
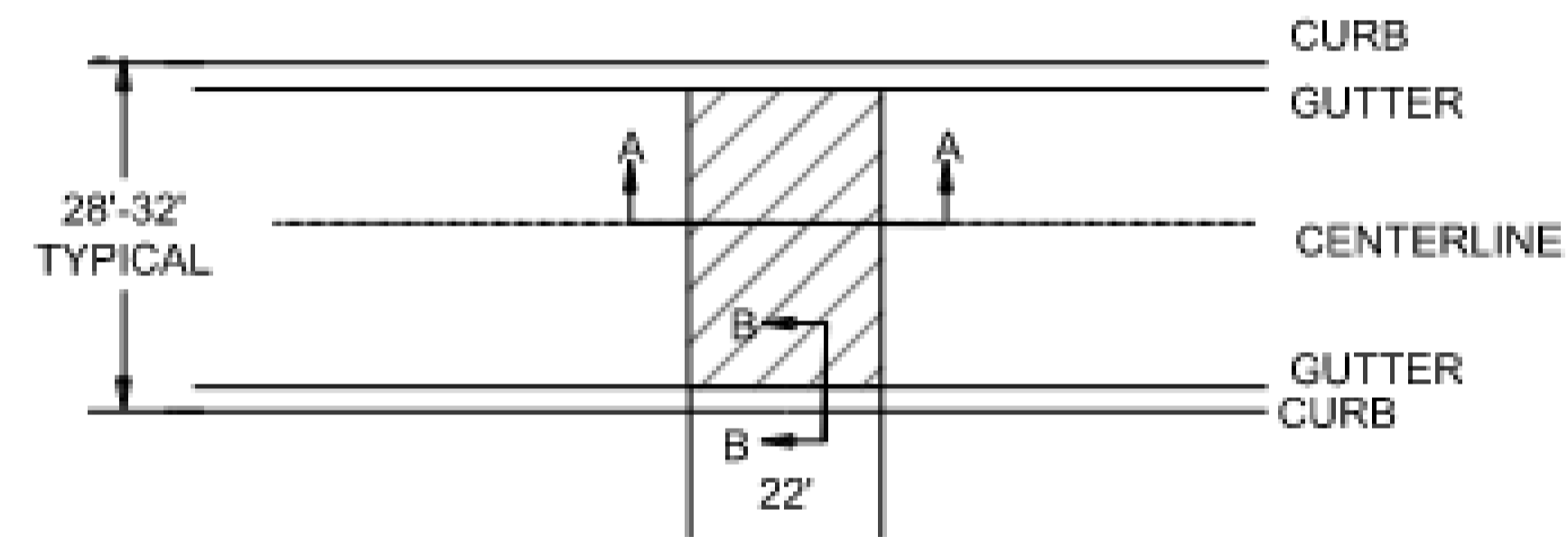
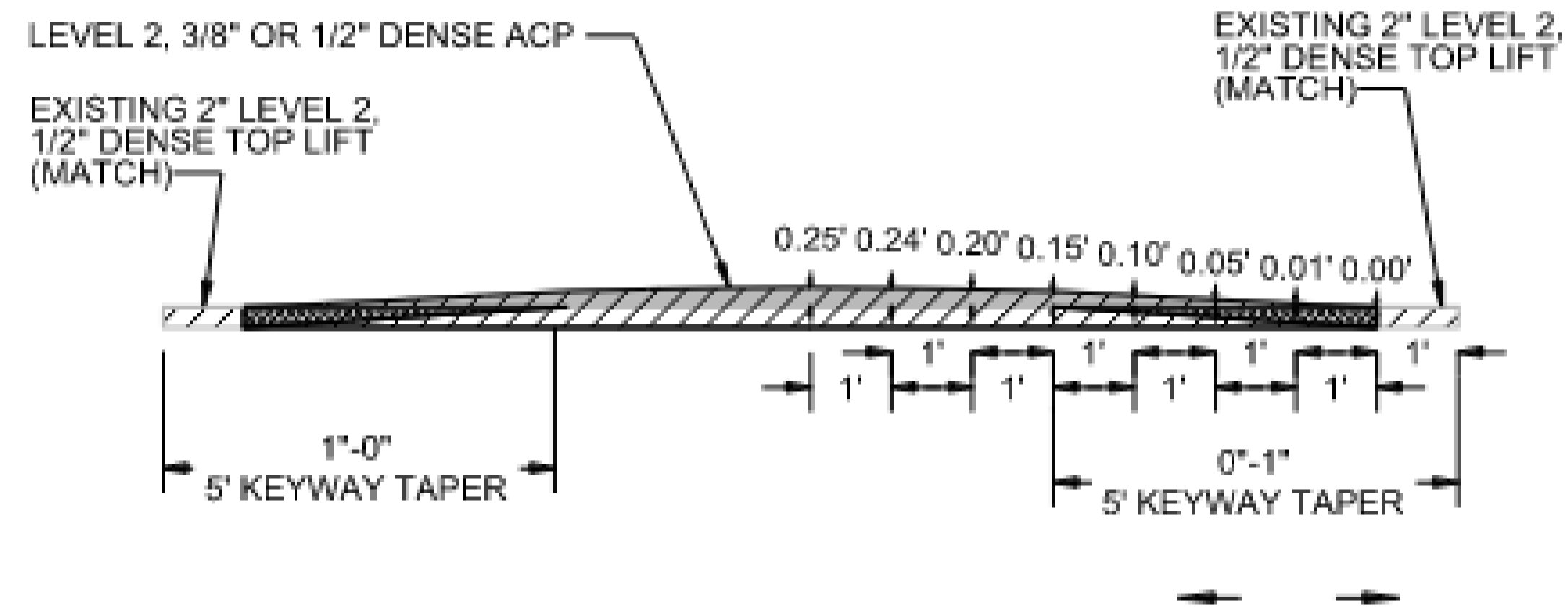

SPEED TABLE - SECTION A-A

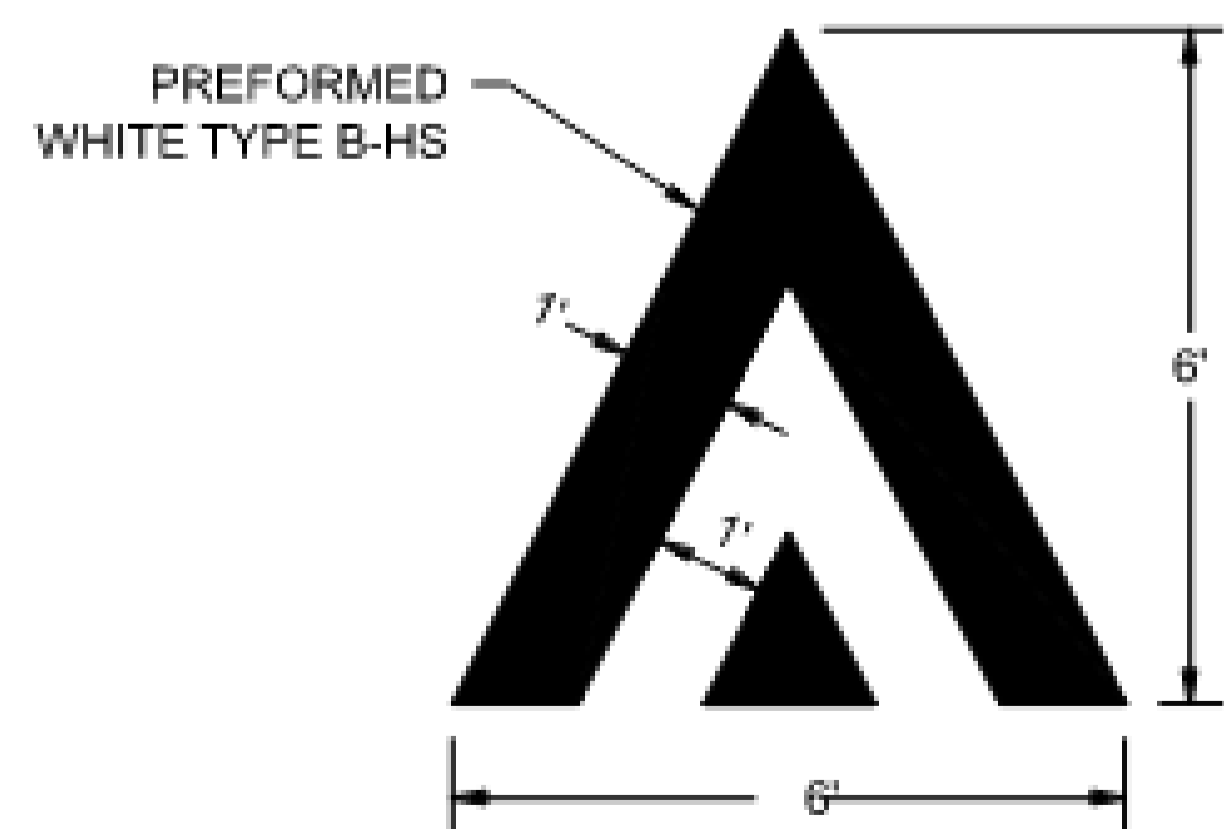

SHM SPEED TABLE MARKING

NOTES :

1. EXACT LOCATIONS WILL BE MARKED IN THE FIELD BY THE ENGINEER.
2. TAPER GRIND AS SHOWN OR PAVE OVER PAPER FOR REMOVAL AND FULL STRUCTURE CONSTRUCTION.
3. ALL ORGANIC MATERIALS IN CRACKS OR JOINTS SHALL BE REMOVED PRIOR TO PAVING.
4. APPLY AN ASPHALT TACK COAT TO COMPLETELY COVER EXISTING SURFACES, BASE PAVING AND VERTICAL SURFACES, IMMEDIATELY PRIOR TO PAVING.
5. 1/2" DENSE ACP AND TACK COAT SHALL BE PLACED WHEN THE AVERAGE SURFACE TEMPERATURE IS NOT LESS THAN 40 DEGREES FAHRENHEIT.
6. ALL VERTICAL DIMENSIONS SHALL BE CONSIDERED TO +/- 0.25 INCH.
7. APPLY AN EMULSIFIED ASPHALT SEALANT

SPEED TABLE DETAIL

REVISIONS	
DATE	DESCRIPTION
01/15	RENUMBERED FROM CTM509
/	

NO.	REVISIONS	DATE	BY
7			
6			
5			
4			
3			
2			
1			

COPYRIGHT © 2025  
 SUMMIT  
 DESIGN AND ENGINEERING SERVICES  
 ENGINEERING  
 1155 W. STATE ST. SUITE 200  
 DURHAM, NC 27701  
 TEL: (919) 733-8833 FAX: (919) 733-6676  
 WWW.SUMMITDESIGN.COM

Randall Moore  
 PROJECT MANAGER  
 RM/RANDALL.MOORE@SUMMITDE.COM  
 DRAWN BY  
 RM/RANDALL.MOORE@SUMMITDE.COM  
 FIRST ISSUE DATE  
 2/18/2026

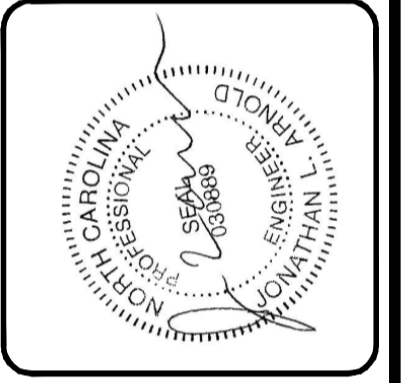

**SUMMIT**  
 DESIGN AND ENGINEERING SERVICES  
 State License # C-3176  
 301 Executive Court  
 Raleigh, NC 27603  
 Tel: (919) 733-8833 Fax: (919) 733-6676  
 www.summitde.com

**LITTLE RIVER REGIONAL PARK**  
 REPAVING PROJECT  
 301 LITTLE RIVER PARK WAY,  
 ROUGEMONT, NC 27572  
 Owner:  
 Orange County Department of Environment, Agriculture, Parks,  
 and Recreation  
 Durham County Parks and Recreation

PROJECT NO.  
 25-0022.225  
 SHEET NO.  
 S-2  
 DETAIL NO.  
 SD-1

METHOD OF PIPE INSTALLATION  
FLEXIBLE PIPE

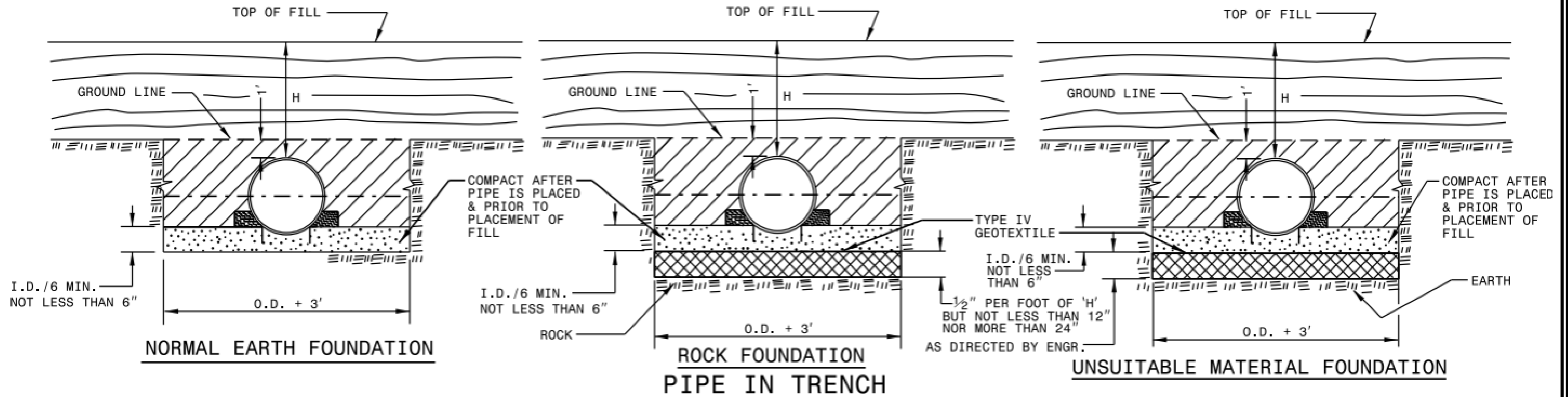

GENERAL NOTES:

I.D. = THE MAXIMUM HORIZONTAL INSIDE DIAMETER DIMENSION.

O.D. = THE MAXIMUM HORIZONTAL OUTSIDE DIAMETER DIMENSION.

H = THE FILL HEIGHT MEASURED VERTICALLY AT ANY POINT ALONG THE PIPE FROM THE TOP OF THE PIPE TO THE TOP OF THE EMBANKMENT AT THAT POINT.



APPROVED SUITABLE LOCAL MATERIAL.

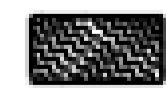

TAKE CARE TO FULLY COMPACT HAUNCH ZONE OF PIPE BACKFILL.



LOOSELY PLACED SELECT MATERIAL CLASS III OR CLASS II, TYPE 1 FOR PIPE BEDDING. LEAVE SECTION DIRECTLY BENEATH PIPE UNCOMPACTED AS PIPE SEATING AND BACKFILL WILL ACCOMPLISH COMPACTION.

DO NOT OPERATE HEAVY EQUIPMENT OVER ANY PIPE CULVERT UNTIL THE PIPE CULVERT HAS BEEN PROPERLY BACKFILLED AND COVERED WITH AT LEAST 3 FEET OF APPROVED MATERIAL.

REFER TO NCDOT PIPE MATERIAL SELECTION GUIDE AND STANDARD SPECIFICATIONS FOR ALLOWABLE PIPE FILL HEIGHTS AND PIPE SPECIFICATIONS.

--- SPRINGLINE OF PIPE



SELECT BACKFILL MATERIAL CLASS III OR CLASS II, TYPE 1 ABOVE AND BELOW SPRINGLINE.



UNDISTURBED EARTH MATERIAL



SELECT MATERIAL CLASS V OR VI FOR FOUNDATION CONDITIONING. ENCAPSULATE WITH TYPE IV GEOTEXTILE AS DIRECTED BY THE ENGINEER.

PIPE TO BE INSTALLED AT DEPTH GREATER OR EQUAL TO MANUFACTURER REQUIRED MINIMUM COVERAGE

NO.	REVISIONS	DATE	BY
7			
6			
5			
4			
3			
2			
1			

COPYRIGHT © 2025  
SUMMIT  
ENGINEERING SERVICES  
ALL RIGHTS RESERVED.  
THIS DRAWING IS THE PROPERTY OF SUMMIT ENGINEERING SERVICES. IT IS TO BE USED ONLY FOR THE PROJECT AND SITE SPECIFICALLY IDENTIFIED IN THE TITLE BLOCK. NO PART OF THIS DRAWING IS TO BE REPRODUCED OR TRANSMITTED IN ANY FORM OR BY ANY MEANS, ELECTRONIC OR MECHANICAL, INCLUDING PHOTOCOPYING, RECORDING, OR BY ANY INFORMATION STORAGE AND RETRIEVAL SYSTEM, WITHOUT THE WRITTEN PERMISSION OF SUMMIT ENGINEERING SERVICES.

PROJECT MANAGER  
RANDALL MOORE  
RANDALL.MOORE@SUMMITDE.COM

DRAWN BY  
RANDALL MOORE  
RANDALL.MOORE@SUMMITDE.COM

FIRST ISSUE DATE  
2/18/2026



**SUMMIT**  
DESIGN AND ENGINEERING SERVICES  
State License # C-5176  
307 Executive Court  
Durham, NC 27709  
Voice: (919) 732-3883 Fax: (919) 732-6676  
www.summitde.com

**LITTLE RIVER REGIONAL PARK**  
**REPAVING PROJECT**  
301 LITTLE RIVER PARK WAY,  
ROUGEMONT, NC 27572  
Owner: Orange County Department of Environment, Agriculture, Parks, and Recreation  
Durham County Parks and Recreation

PROJECT NO.  
25-0022.225  
SHEET NO.  
S-3  
DETAIL NO.  
SD-2

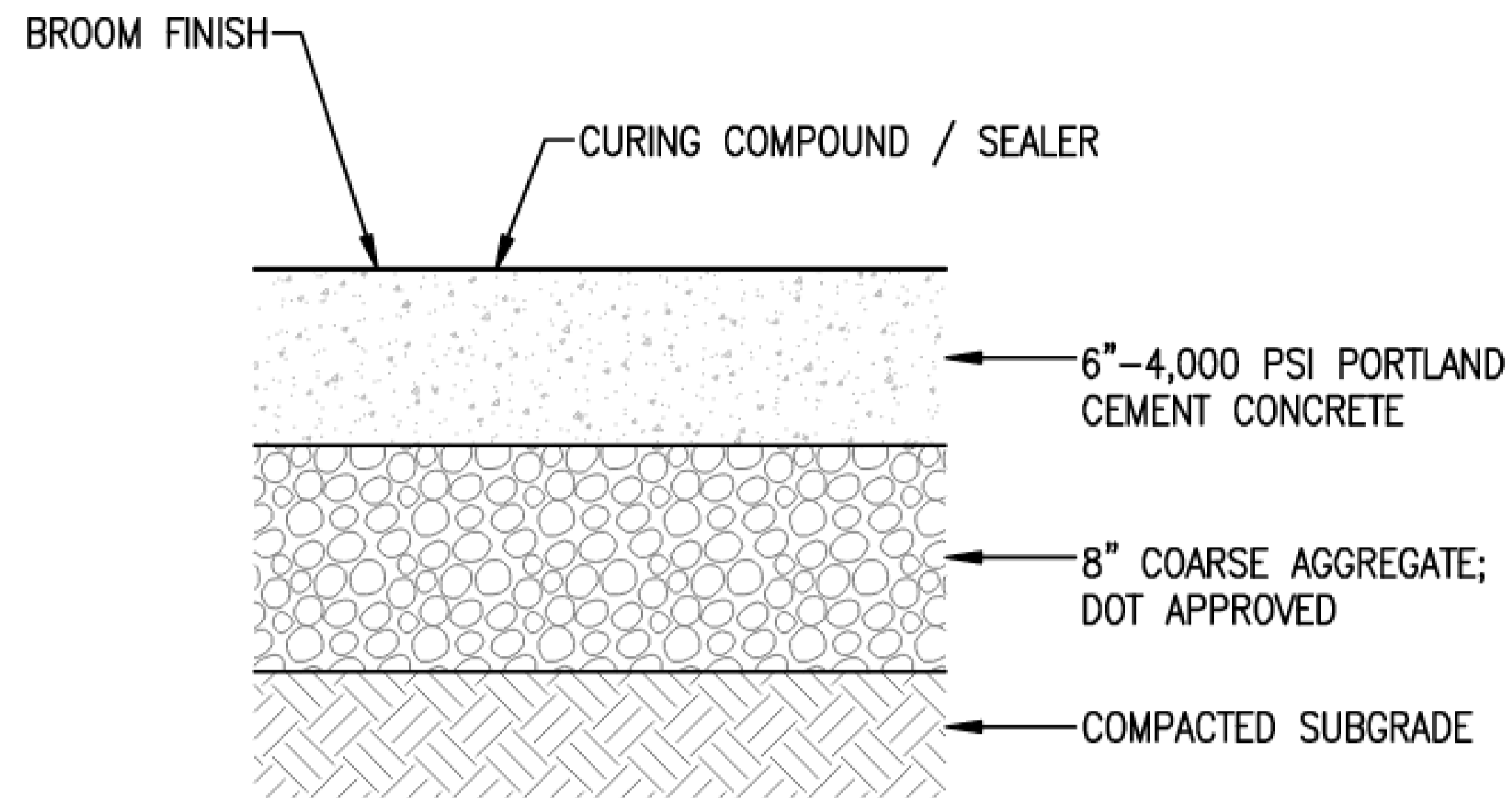

**NOTES:**

SECTION SHOWN IS FOR AREAS OF NEW CONCRETE PAVEMENT. AREAS WHERE PAVEMENT IS BEING REPLACED, THE EXISTING AGGREGATE SHALL BE LEFT IN PLACE, FINE GRADED AND RE-COMPACT PRIOR TO NEW CONCRETE PLACEMENT.

PRIOR TO PLACEMENT OF AGGREGATE SUBBASE COURSE, THE PAVEMENT SUBGRADE SHALL BE PREPARED AS FOLLOWS:

- A. THE UPPER 12 INCHES OF EXPOSED SUBGRADE SHALL BE SCARIFIED AND COMPACTED TO AT LEAST 95% OF ITS MAXIMUM DRY DENSITY AND WITHIN  $\pm 3\%$  OF ITS OPTIMUM MOISTURE CONTENT, AS DETERMINED BY ASTM D698 (STANDARD PROCTOR). ANY SOFT AREAS SHALL BE OVEREXCAVATED TO A FIRM AND COMPETENT MATERIAL AND BACKFILLED AS DESCRIBED ABOVE.
- B. AFTER COMPACTION, THE PAVEMENT SUBGRADE SHALL PROVIDE A FIRM UNYIELDING FOUNDATION WITH NO SUDDEN, SHARP OR ABRUPT CHANGES OR BREAKS IN GRADES. NO STANDING WATER OR EXCESS MOISTURE SHALL BE PRESENT. ALL SOFT AND YIELDING AREAS SHALL BE REWORKED BY OVEREXCAVATING TO A FIRM AND COMPETENT MATERIAL THEN BACKFILLED AS DESCRIBED IN NOTE 2 ABOVE.
- C. THE SUBGRADE SHALL BE GRADED AND SHAPED AS REQUIRED TO CONSTRUCT THE AGGREGATE BASE COURSE IN CONFORMANCE WITH THE GRADES, LINES, AND THICKNESS SHOWN ON THE DRAWINGS.

CONCRETE MIX DESIGN SHALL BE SUBMITTED FOR REVIEW AND APPROVAL.

CONTRACTOR SHALL CONSTRUCT FULL DEPTH PAVEMENT SECTION WITH FINAL TOP ELEVATION MATCHING ADJACENT GRADES.

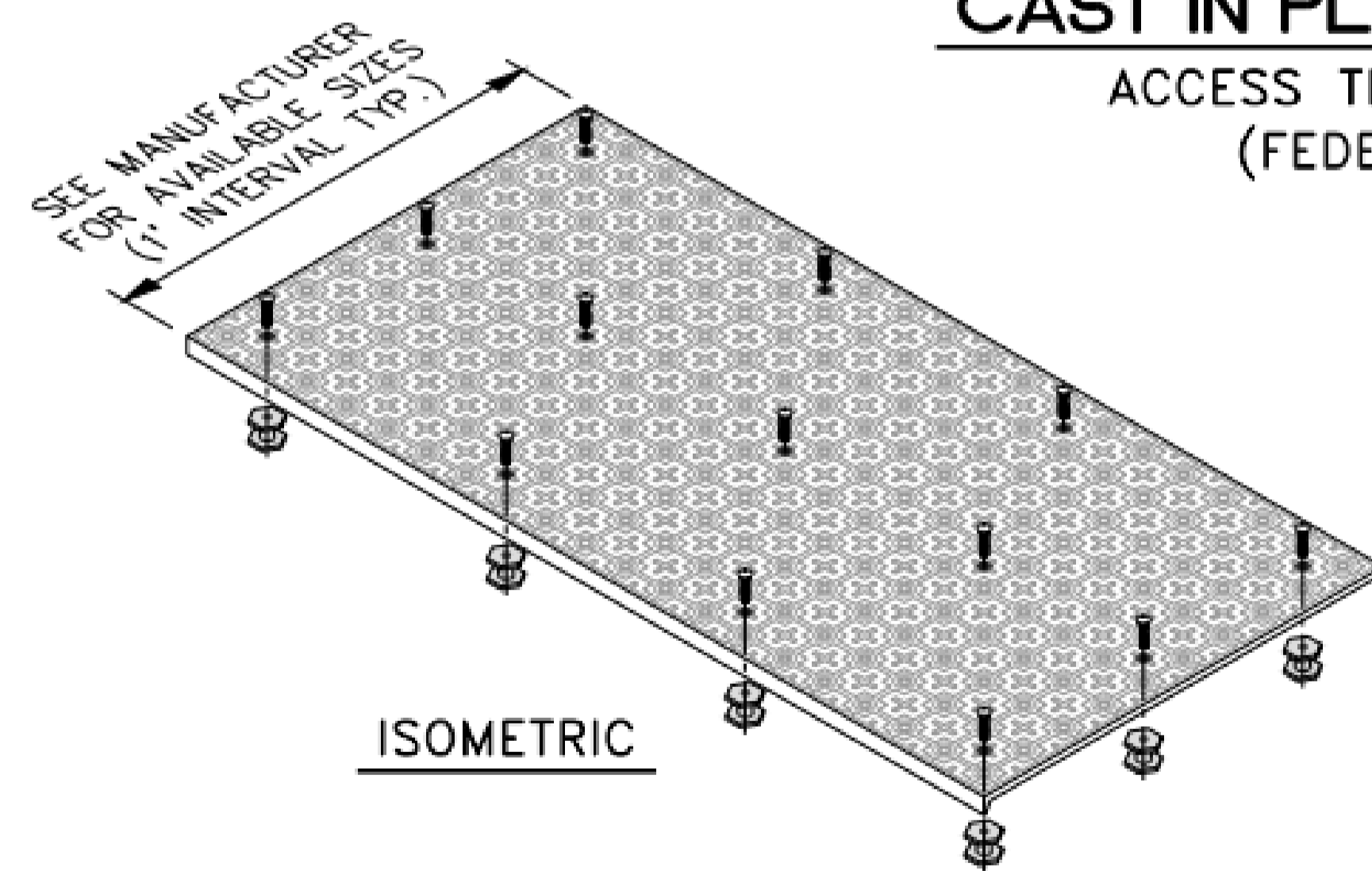
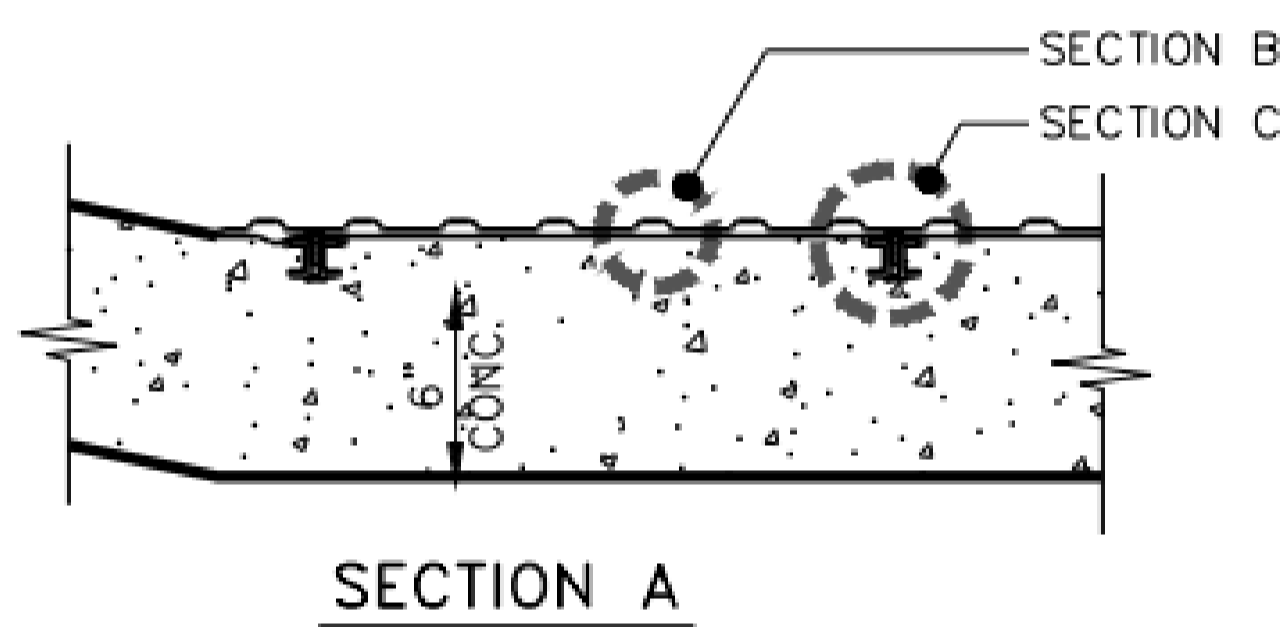
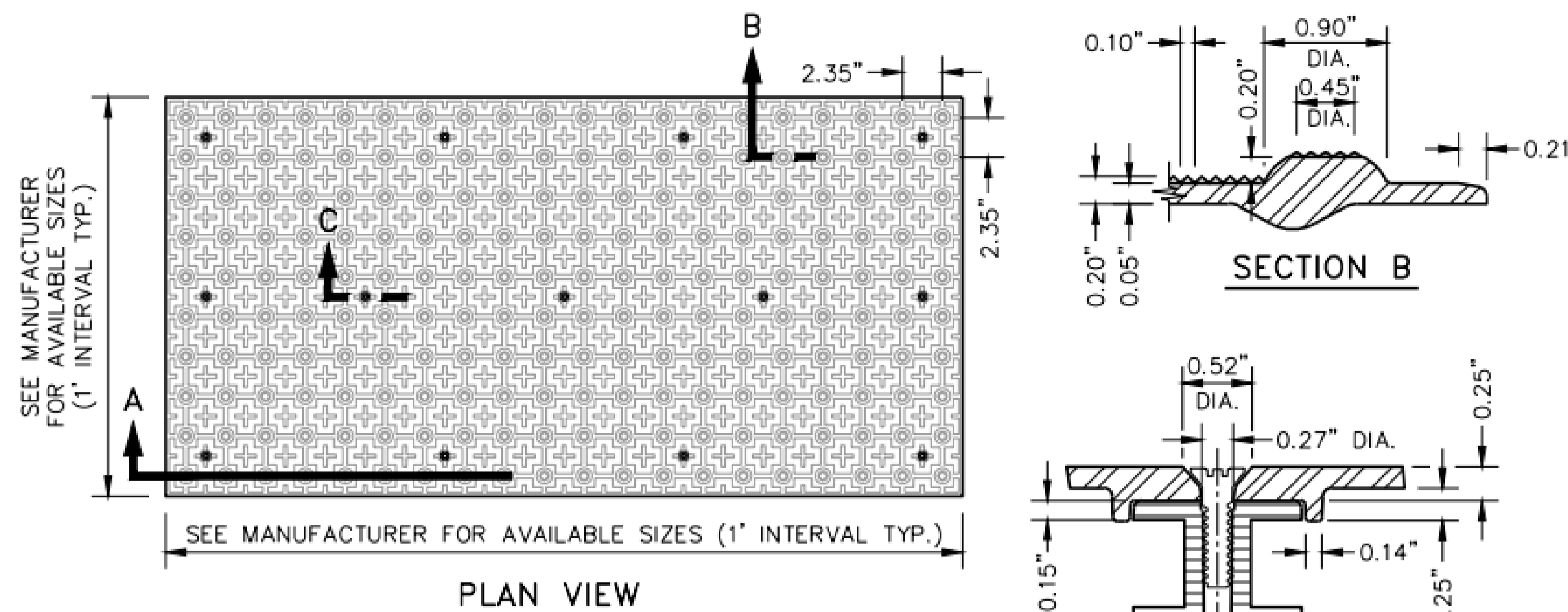

**NYLON COMPOSITE  
CAST IN PLACE / REPLACEABLE  
ACCESS TILE BY TACTILE SYSTEMS  
(FEDERAL YELLOW ONLY)**

**NOTES:**

- 1. Contact manufacturer for sizes and shapes available in addition to detailed installation instructions.

NO.	REVISIONS	DATE	BY
7			
6			
5			
4			
3			
2			
1			

COPYRIGHT © 2025  
SUMMIT  
DESIGN AND ENGINEERING SERVICES  
ALL RIGHTS RESERVED.  
THIS DRAWING IS THE PROPERTY OF SUMMIT DESIGN AND ENGINEERING SERVICES. IT IS TO BE USED ONLY FOR THE PROJECT AND SITE SPECIFICALLY IDENTIFIED IN THE TITLE BLOCK. NO PART OF THIS DRAWING IS TO BE REPRODUCED OR TRANSMITTED IN ANY FORM OR BY ANY MEANS, ELECTRONIC OR MECHANICAL, INCLUDING PHOTOCOPYING, RECORDING, OR BY ANY INFORMATION STORAGE AND RETRIEVAL SYSTEM, WITHOUT THE WRITTEN PERMISSION OF SUMMIT DESIGN AND ENGINEERING SERVICES.

**Randall Moore**  
PROJECT MANAGER  
RM/RANDALLMOORE@SUMMITDE.COM  
DRAWN BY  
RW/RANDALLMOORE@SUMMITDE.COM  
FIRST ISSUE DATE  
2/18/2025



**SUMMIT**  
DESIGN AND ENGINEERING SERVICES  
State License #: C-5176  
301 Executive Court  
Durham, NC 27709  
Voice: (919) 732-5883 Fax: (919) 732-6676  
www.summitde.com

**LITTLE RIVER REGIONAL PARK  
REPAVING PROJECT**  
301 LITTLE RIVER PARK WAY,  
ROUGEMONT, NC 27572  
Owner:  
Orange County Department of Environment, Agriculture, Parks,  
and Recreation  
Durham County Parks and Recreation

PROJECT NO.  
25-0022.225  
SHEET NO.  
S-4  
DETAIL NO.  
SD-3

C:\Users\frankie.winn\Desktop\Elementary School\Civil Template (COPY THIS)\Current Drawings\XX-XXX\_S.dwg, 7/18/2025 12:50:22 PM, frankie.winn, DWG To PDF.pc3

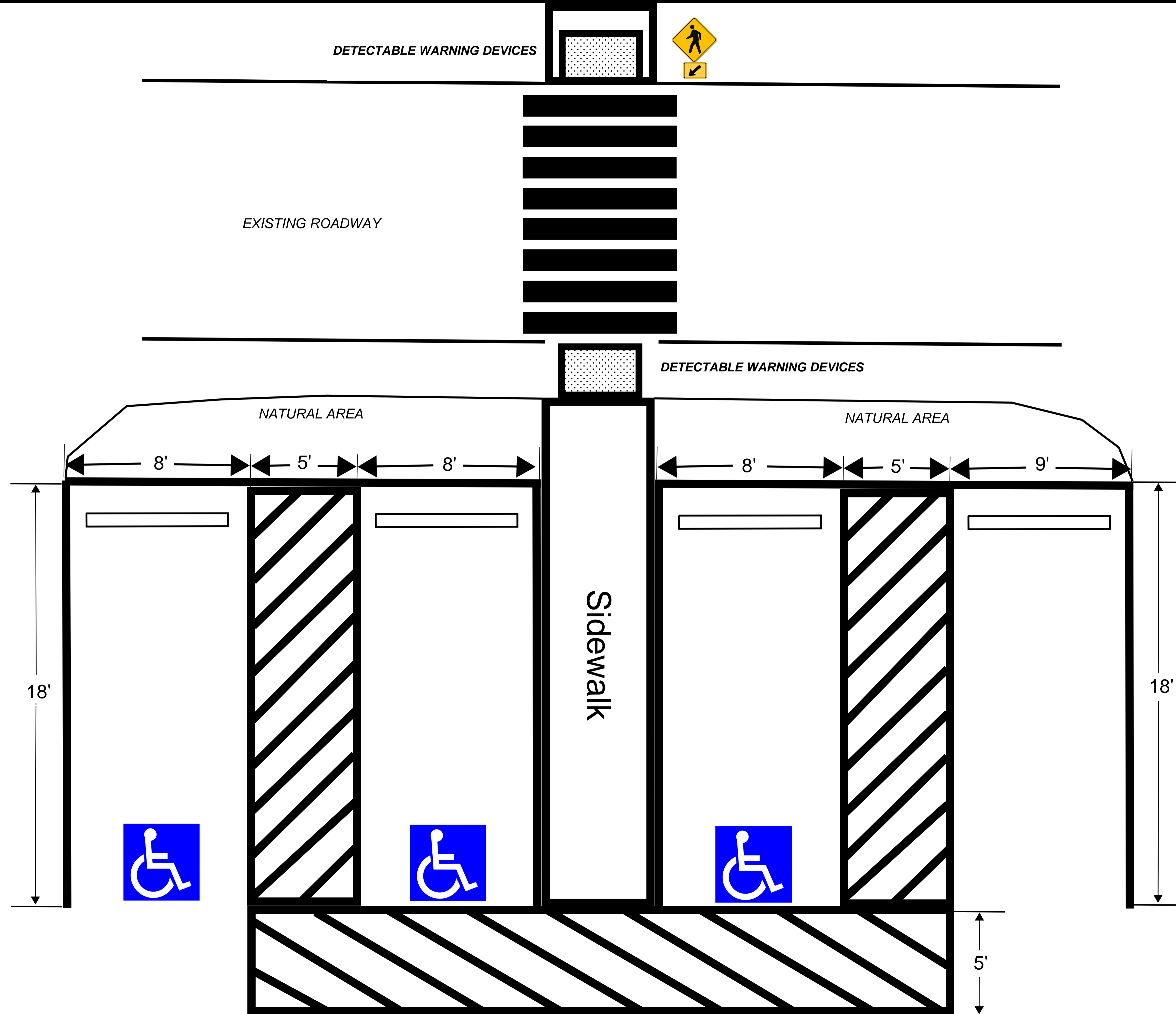

CONCRETE ADA HANDICAP PARKING SPACES AND LOADING ZONES TO NO MORE THAN 2% SLOPE IN ANY DIRECTIONS  
ALL PAINT STRIPING TO 4" WHITE

<p><b>LITTLE RIVER REGIONAL PARK</b>  <b>REPAVING PROJECT</b>          301 LITTLE RIVER PARK WAY,          ROUGEMONT, NC 27572</p> <p>Owner:          Orange County Department of Environment, Agriculture, Parks,          and Recreation          Durham County Parks and Recreation</p>		<p>PROJECT NO. 25-0022.225</p> <p>SHEET NO. S-5</p> <p>DETAIL NO.</p>																								
<p><b>SUMMIT</b>          DESIGN AND ENGINEERING SERVICES</p> <p>State License #: C-5176          301 Executive Court          Wake Forest, NC 27579          Voice: (919) 732-3883 Fax: (919) 732-6676          www.summitde.com</p>		<p>Randall Moore          PROJECT MANAGER          RM/RANDALL.MOORE@SUMMITDE.COM</p> <p>DRAWN BY          RM/RANDALL.MOORE@SUMMITDE.COM</p> <p>FIRST ISSUE DATE          2/18/2026</p>																								
<p>Copyright © 2025          Summit Design and Engineering Services          All rights reserved. No part of this document may be reproduced, stored in a retrieval system, or transmitted in any form or by any means, electronic, mechanical, photocopying, recording, or by any information storage and retrieval system, without the prior written permission of Summit Design and Engineering Services.</p>		<p>REVISIONS</p> <table border="1"> <tr><th>NO.</th><th>DATE</th><th>BY</th></tr> <tr><td>7</td><td></td><td></td></tr> <tr><td>6</td><td></td><td></td></tr> <tr><td>5</td><td></td><td></td></tr> <tr><td>4</td><td></td><td></td></tr> <tr><td>3</td><td></td><td></td></tr> <tr><td>2</td><td></td><td></td></tr> <tr><td>1</td><td></td><td></td></tr> </table>	NO.	DATE	BY	7			6			5			4			3			2			1		
NO.	DATE	BY																								
7																										
6																										
5																										
4																										
3																										
2																										
1																										

# HIGH VISIBILITY CROSSWALK DETAIL

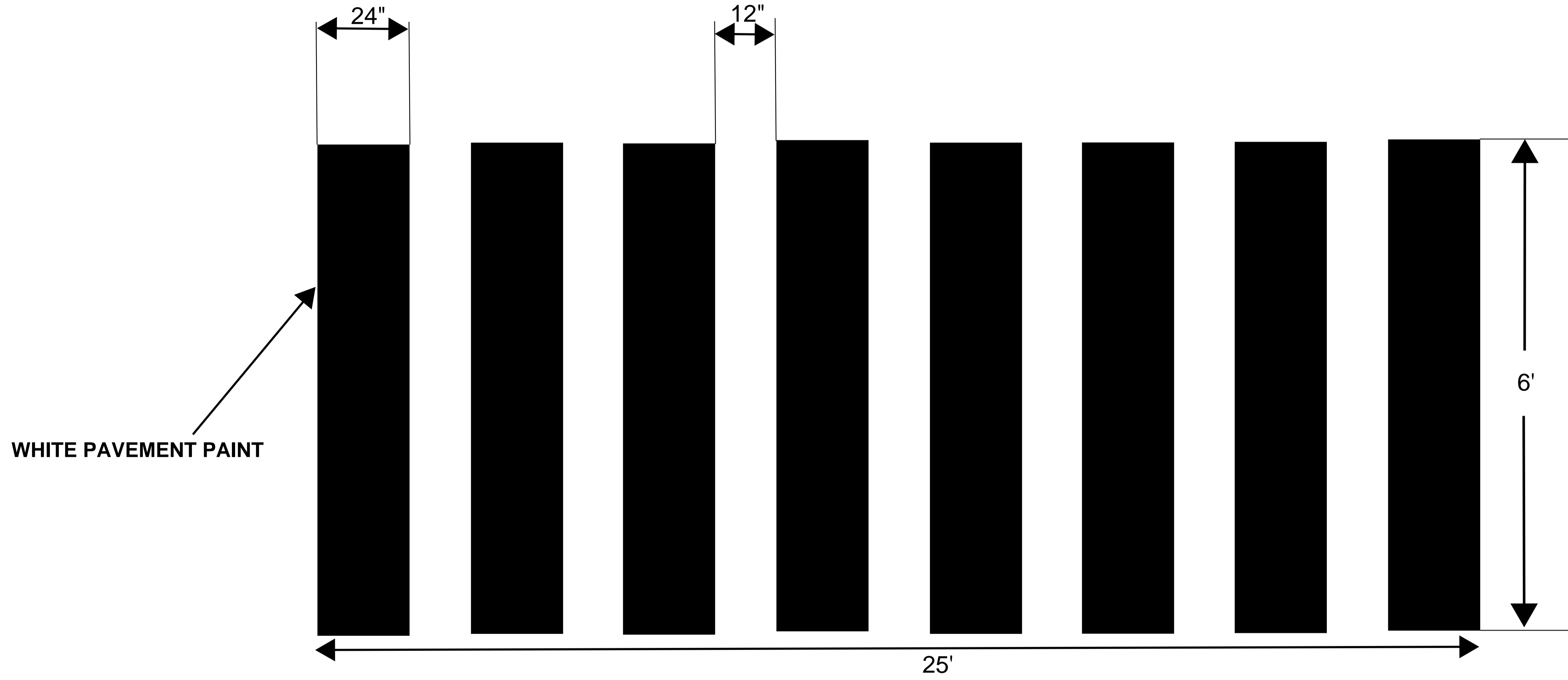

PROJECT NO.  
25-0022.225

SHEET NO.  
S-6

DETAIL NO.

**LITTLE RIVER REGIONAL PARK  
REPAVING PROJECT**  
301 LITTLE RIVER PARK WAY,  
ROUDEMONT, NC 27572

Owner:  
Orange County Department of Environment, Agriculture, Parks,  
and Recreation  
Durham County Parks and Recreation

**SUMMIT**  
DESIGN AND ENGINEERING SERVICES

State License #: C-3176  
301 Executive Court  
Durham, NC 27709  
Voice: (919) 732-3883 Fax: (919) 732-6676  
www.summitde.com

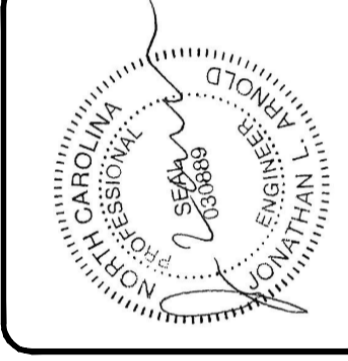

**Randall Moore**  
PROJECT MANAGER  
RM/RANDALLMOORE@SUMMITDE.COM

DRAWN BY  
RM/RANDALLMOORE@SUMMITDE.COM

FIRST ISSUE DATE  
2/18/2026

COPYRIGHT © 2025  
SUMMIT DESIGN AND ENGINEERING SERVICES  
ALL RIGHTS RESERVED. NO PART OF THIS DOCUMENT MAY BE REPRODUCED OR TRANSMITTED IN ANY FORM OR BY ANY MEANS, ELECTRONIC OR MECHANICAL, INCLUDING PHOTOCOPYING, RECORDING, OR BY ANY INFORMATION STORAGE AND RETRIEVAL SYSTEM, WITHOUT THE WRITTEN PERMISSION OF SUMMIT DESIGN AND ENGINEERING SERVICES.

NO.	REVISIONS	DATE	BY
7			
6			
5			
4			
3			
2			
1			

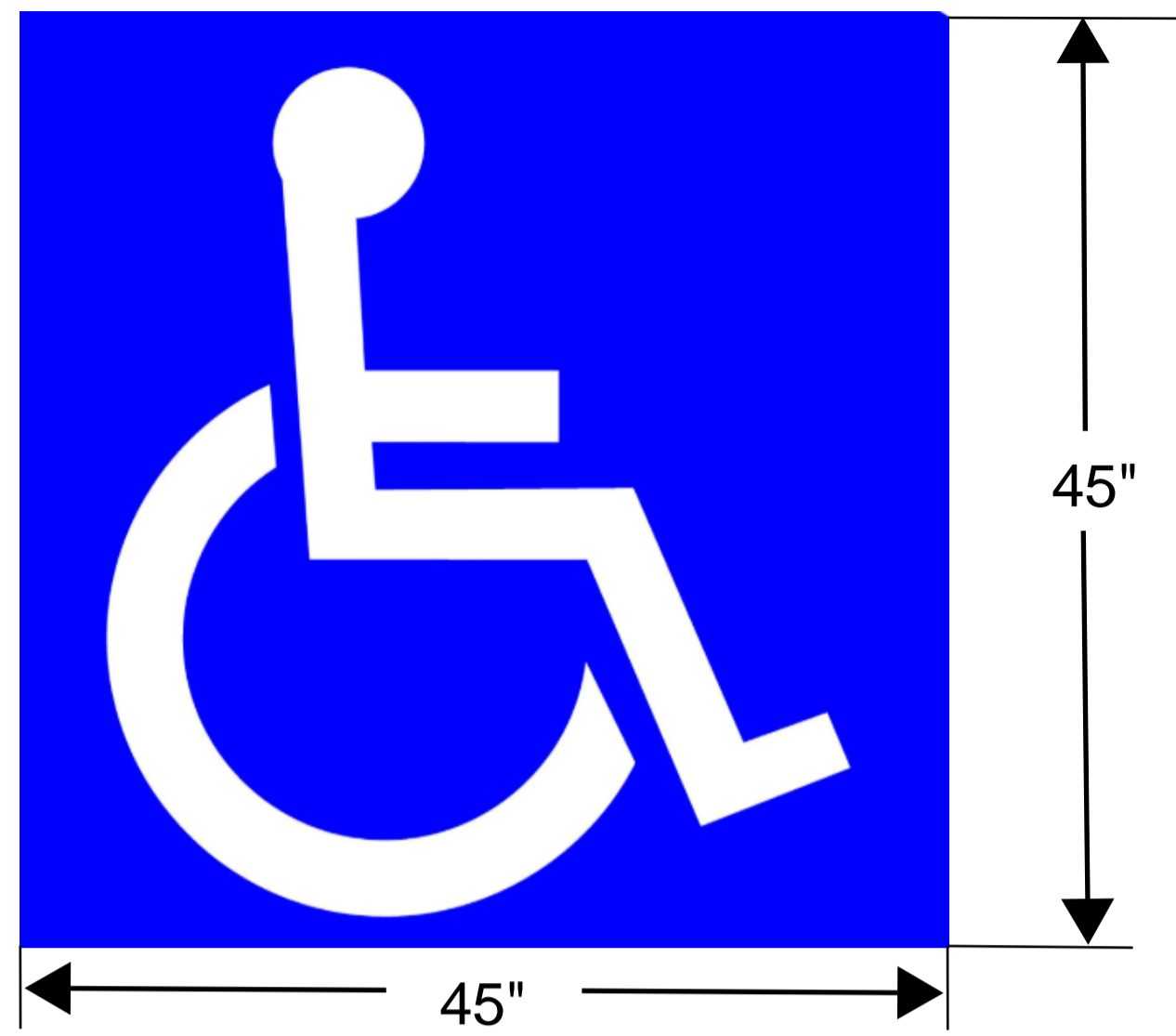

**HANDICAP STRIPING DETAIL**

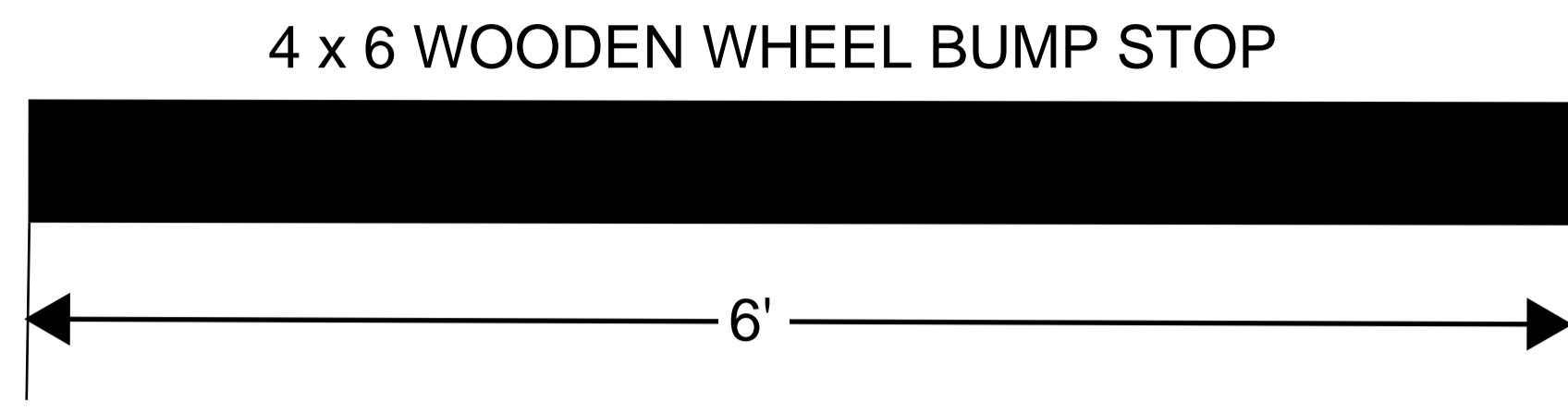

**4 x 6 WOODEN WHEEL BUMP STOP**  
WHEEL BUMP STOP TO BE PRESSURE TREATED LUMBER

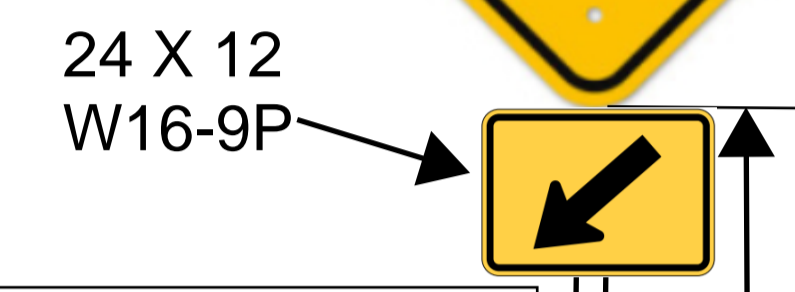

**3" GALVANIZED STEEL POLE OR 2" X 2" GAGE GALVANIZED SIGN POST**

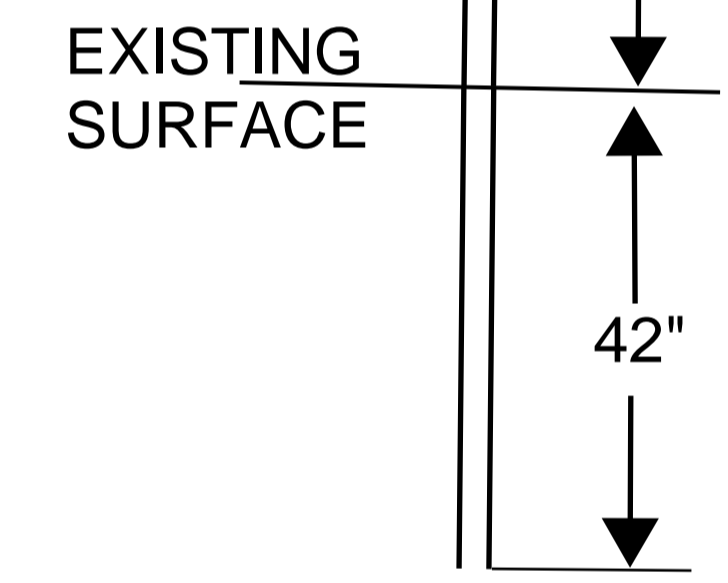

**PEDESTRIAN CROSSING WARNING SIGN TO BE INSTALLED ON RIGHT SIDE OF DRIVE AISLE**

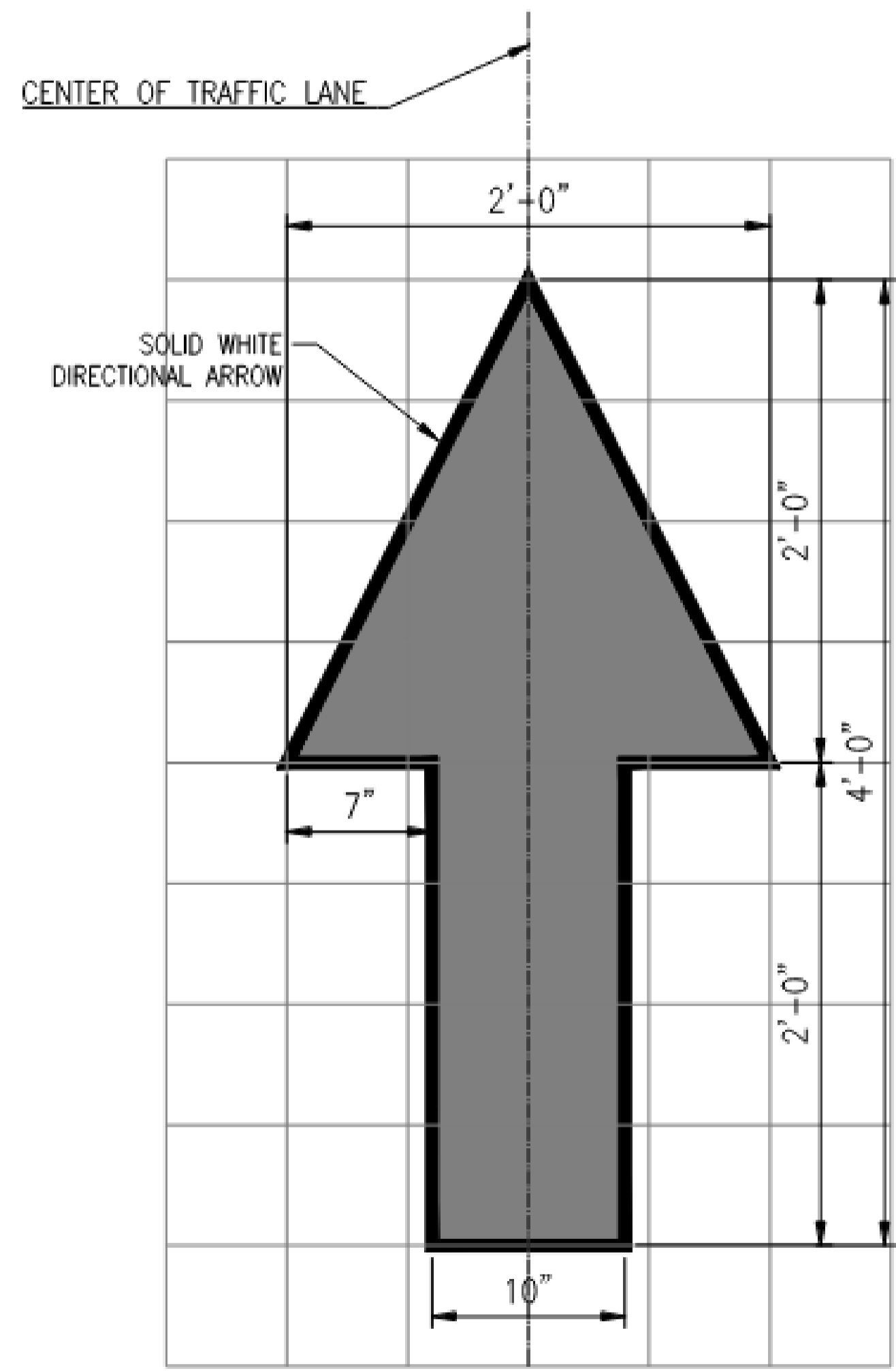

**STRAIGHT ARROW DETAIL**

**PARKING SPACES TO BE STRIPED WITH 4" WHITE PAINT**

NO.	REVISIONS	DATE	BY
7			
6			
5			
4			
3			
2			
1			

COPYRIGHT © 2025  
SUMMIT  
ENGINEERING SERVICES  
ALL RIGHTS RESERVED.  
THIS DOCUMENT IS THE PROPERTY OF  
SUMMIT ENGINEERING SERVICES. IT IS TO BE  
USED ONLY FOR THE PROJECT AND SITE  
SPECIFICALLY IDENTIFIED IN THE  
DRAWINGS. NO PART OF THIS DOCUMENT  
SHALL BE REPRODUCED OR TRANSMITTED  
IN ANY FORM OR BY ANY MEANS,  
ELECTRONIC OR MECHANICAL, INCLUDING  
PHOTOCOPYING, RECORDING, OR BY ANY  
INFORMATION STORAGE AND RETRIEVAL  
SYSTEM, WITHOUT PERMISSION IN WRITING  
FROM THE ENGINEER AND ARCHITECT.

**Randall Moore**  
PROJECT MANAGER  
RM/RANDALL.MOORE@SUMMITDE.COM

**DRAWN BY**  
RM/RANDALL.MOORE@SUMMITDE.COM

FIRST ISSUE DATE  
2/18/2026

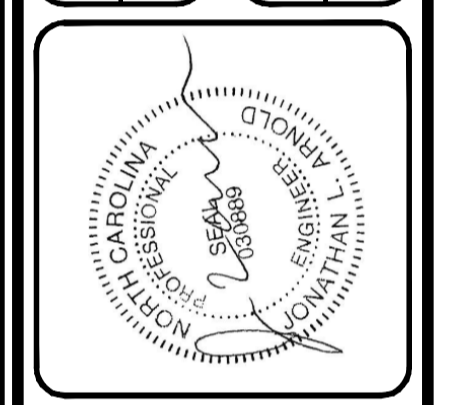

**SUMMIT**  
DESIGN AND ENGINEERING SERVICES

State License #: C-5176  
301 Executive Court  
Raleigh, NC 27603  
Phone: (919) 732-3883 Fax: (919) 732-6676  
www.summitde.com

**LITTLE RIVER REGIONAL PARK  
REPAVING PROJECT**  
301 LITTLE RIVER PARK WAY,  
ROUDEMONT, NC 27572

Owner:  
Orange County Department of Environment, Agriculture, Parks,  
and Recreation  
Durham County Parks and Recreation

PROJECT NO.  
25-0022.225

SHEET NO.  
S-7

DETAIL NO.

