

NC STATE UNIVERSITY

Raleigh, North Carolina Request for Quotation (RFQ)

#63-ARM1179180 - Custom Ultra High Vacuum Chamber

For internal administrative processing, including tabulation of bids for posting to Bonfire and the State of North Carolina Electronic Vendor Portal (eVP), please provide your company's Federal Employer Identification Number or alternate identification number (e.g. Social Security Number). We HIGHLY recommend you register in order to see bid tabulations and award results. Pursuant to G.S. 132-1.10(b) this identification number shall not be released to the public. This page will be removed and shredded, or otherwise kept confidential, before the procurement file is available for public inspection.

**THIS PAGE IS TO BE COMPLETED AND INCLUDED
WITH YOUR BID. FAILURE TO DO SO MAY SUBJECT
YOUR BID TO REJECTION.**

Federal ID Number or Social Security Number:	
SUPPLIER NAME:	
DATE:	

NC STATE UNIVERSITY

PROCUREMENT & BUSINESS SERVICES

Mailing Address (USPS only): Campus Box 7212 Raleigh,
NC 27695-7212

Shipping Address: Admin. I, 2721 Sullivan Drive, Suite 1100,
Raleigh, NC 27607
Phone (919) 515-2171

**REQUEST FOR QUOTATION
(This is not an order)**

May 26, 2026

REQUIRED SUPPLIER INFORMATION:

Supplier Name & Address:

Authorized Rep's Name:

Title:

Quote # ARM1179180

Email:

Questions Due Date & Time:

06/05/2026, 12:00PM EST

Phone #:

Authorized Representative Signature:

Due Date & Time:

06/11/2026, 5:00PM EST

Buyer Contact Information:

Amy Mears

armears@ncsu.edu, (919) 513-1703

Type of Organization:

- Individual Partnership
- Corporation Other:

Requisition #: 0001179180

Using Department:

Nuclear Engineering

Indicate if other than Large Business:

FOB: DESTINATION - FREIGHT PREPAID

(unless otherwise indicated on RFQ)

- Disabled Minority
- Small Women-Owned

ATTACHMENTS AND COMMENTS:

By responding to this RFQ, supplier acknowledges acceptance of specified Terms and Conditions, which are also located:

<https://procurement.ofa.ncsu.edu/supplier-center/doing-business-with-nc-state/>

- General Terms & Conditions Rental Terms & Conditions
- General Terms & Conditions w/ Software Lease/Purchase Terms & Conditions
- General Terms & Conditions with EO50 Charter Bus Terms & Conditions
- Software Terms & Conditions Service Terms & Conditions
- Software as a Service Terms & Conditions Other:

You MUST register and upload this quote as a PDF to the Bonfire Public Portal here:

<https://ncsu.bonfirehub.com/opportunities/237883>

QUOTES NOT SUBMITTED ON THIS FORM ARE SUBJECT TO REJECTION.

NC State University Request for Quotes and their awards are not subject to the North Carolina E-procurement process.

DEBARMENT CERTIFICATION: By signing the execution page, bidder certifies to the best of its knowledge and belief, that it and its principals are not presently debarred, suspended, proposed for debarment, declined ineligible or voluntary excluded from covered transactions by any Federal or State agency.

PROJECT DESCRIPTION:

NC State University's Nuclear Engineering division is seeking a custom rectangular style AMAROK vacuum chamber needed for their experimental research and development program.

Deadline for Questions 12:00 pm EST, 06/05/2026

All questions must be submitted by email to: amy_mears@ncsu.edu

NO PHONE CALLS ACCEPTED

Communication with the end user while the bid is in process is strictly prohibited.

#	Item Description	Quantity	Unit	Unit Cost	Extended Cost
1	<p>AMAROK Ion Source: Custom Ultra High Vacuum chamber; rectangular design with various CF ports (see attached specifications for details)</p> <p>NOTE: Bidders are required to factor all applicable freight, tariffs, import duties, and related fees into their total bid pricing.</p> <p>Manufacturer: _____</p> <p>Part #: _____</p>	1	EACH		
QUOTE TOTAL					
*NOTE: Bids MUST include data sheets, cut sheets or other descriptive literature. Failure to provide this will subject your quotation to rejection.					
NC State University is exempt from sales and/or use taxes on qualifying purchases. Tax exempt # 400021.					
<p>An ADDENDUM to this RFQ is possible. If required, any subsequent addenda must be submitted prior to the quote closing. It is the vendor's responsibility to verify that all applicable addenda are submitted prior to the quote closing date. Addenda are posted at https://evp.nc.gov/.</p>					
<p>For freight INCOTERMS, NC State University REQUIRES one of the following modes: DAP, DPU, DDP Other freight terms accepted: FOBD (Freight On Board Destination)</p>					
Estimated Delivery timeframe or date:					
Warranty Type and Length:					
<p>PRODUCT SAFETY LISTING: All manufactured items and/or fabricated assemblies subject to operation under pressure, operation by connection to an electric source, or operation involving a connection to a manufactured, natural, or LP gas source shall be constructed and approved in a manner acceptable to the appropriate state inspector which customarily requires the label or re-examination listing or identification marking of the appropriate safety standard organization; such as the American Society of Mechanical Engineers for pressure vessels; the Underwriters Laboratories and /or National Electrical Manufacturers' Association for electrically operated assemblies; or the American Gas Association for gas operated assemblies, where such approvals of listings have been established for the type of device offered and furnished. Further, all items furnished shall meet all requirements of the Occupational Safety and Health Act (OSHA), and state and federal requirements relating to clean air and water pollution.</p>					
<p>Qualified Testing Laboratories in accordance with N.C. GENERAL STATUTE § 66-25 and § 143-139.1: https://www.ncosfm.gov/codes/state-electrical-division/qualified-testing-laboratories</p>					

Custom Ultra High Vacuum Chamber: Rectangular design with various CF ports

Supplier acknowledges agreement to all Ultra High Vacuum Chamber requirements unless specifically noted in writing. Yes

1.0 Preamble - System Level Requirements

- 1.1. A custom rectangular style vacuum chamber with front and back plate and ports for diagnostic and pumping access
- 1.2. It needs to be leak tight mountable to the diagnostic chamber through the defined interface bolt hole pattern
- 1.3. The chamber needs to adhere to requirements written down in Sections 2 to 8.

2.0 Functional Requirements

2.1. Size and Dimensions	
2.1.1. Back Plate	
2.1.1.1. Length	90 cm
2.1.1.2. Thickness / height	2 cm
2.1.1.3. breadth	55 cm
2.1.1.4. Machined serpentine water channel inside the plate	
2.1.1.4.1. Water channel size	¼"OD or smaller
2.1.1.4.2. Connection x2	¼" Female NPT grove
2.1.1.5. Top face	
2.1.1.5.1. Diagnostic ports - CF 40/50	8
2.1.1.5.2. Diagnostic port per side	2
2.1.1.5.3. Gas feed throughs	2
2.1.1.5.4. Cooling water feedthrough - CF45/50	2
2.1.1.5.6. Secondary vacuum cutout	1 (edge)

2.1.1.6. Back face	
2.1.1.6.1. Race track shape groove for quartz placement	70cm x 15cm(radius)
2.1.1.6.2. Groove for O-ring for bucket	0.25cm deep
2.1.2. Front Plate	
2.1.2.1. Length	90 cm
2.1.2.2. Thickness / height	2 cm
2.1.2.3. Breadth	55 cm
2.1.2.4. Machined serpentine water channel inside the plate	
2.1.2.4.1. Water channel size	¼"OD or smaller
2.1.2.4.2. Connection x2	¼" Female NPT groove
2.1.2.5. Extraction hole	
2.1.2.5.1. Width from inside face	20 cm
2.1.2.5.2. Length from inside face	56.6 cm
2.1.2.5.3. Chamfer from inside face to outward face	2 cm
2.1.2.5.4. Rounded edge	2 cm
2.1.2.6 Groove for O-ring for bucket	0.25cm deep
2.1.2.6 Groove for O-ring for diagnostic chamber	0.25cm deep
2.1.3. Bucket	
2.1.3.1. Length (inside)	84 cm
2.1.3.2. Width (inside)	48 cm
2.1.3.3. Length (outside w/ lip)	90 cm
2.1.3.4. Width (outside w/ lip)	55 cm
2.1.3.5. Thickness	1 cm
2.1.3.6. Diagnostic Ports - CF 40/50	8
2.1.3.6.1. Diagnostic port per side	2
2.1.3.6.2. Distance between two diagnostic per face	6 cm

2.1.3.7. Lifting eye bolts on 1 face of bucket	2
2.1.4. O-rings for vacuum seals	3
2.2. Material Requirements	
2.2.1. Material Requirement	304 Stainless Steel
2.2.2. Surface finish for vacuum O-rings	Smooth
2.2.3. Material Welds	Inside
2.3. Sealing Mechanisms	
2.3.1. Welding	Inside
2.3.2. O-ring for interface plate with 60 bolt holes (tapped) exact drawing provided in the design phase	3
2.4. Ports and Flanges	
2.4.1. Front plate	
2.4.1.1. Diagnostic ports	
2.4.1.1.1. Quantity	8
2.4.1.1.2. Size	CF 40/50
2.4.1.1.3. Location	See Sec. 3 for location
2.4.1.2. Diagnostic View ports	
2.4.1.2.1. Quantity	8
2.4.1.2.2. Size	CF 40/50
2.4.1.2.3. Location	See Sec. 3 for location

3.0 Drawing of the chamber for visual aid

Components:

1. Front Plate
2. Back Plate
3. Bucket

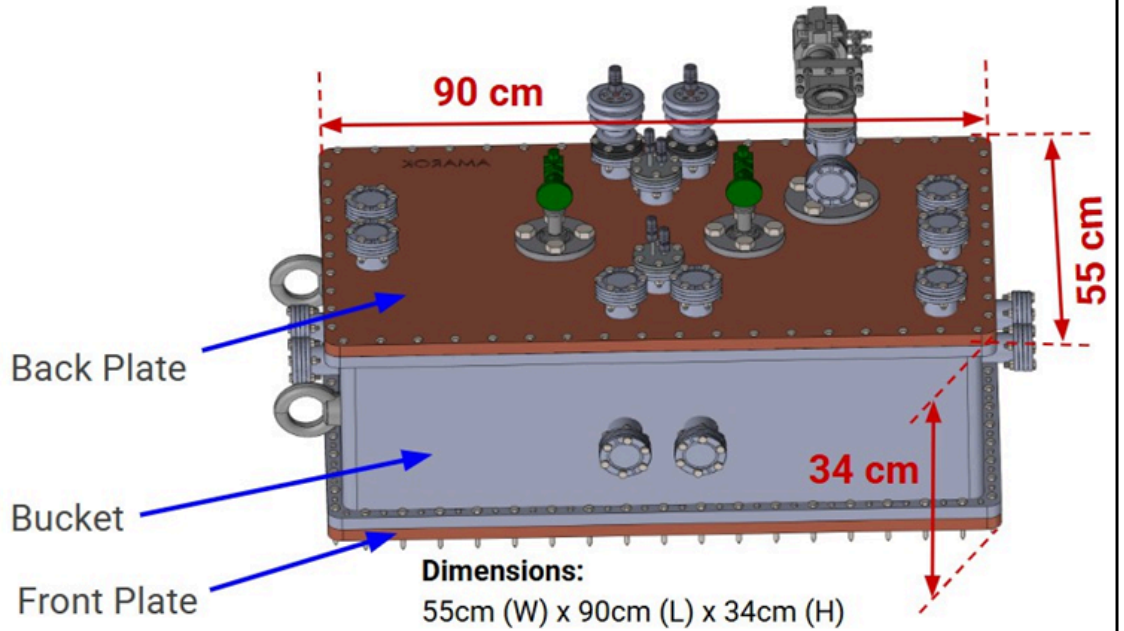

Front Plate - Also SS304

- 2cm thickness SS 304 plate
- Through-holes mount on diagnostic chamber
 - M4 screws
 - 5cm apart
- Every other hole - tapped
 - M4 screws
 - Connect to SS bucket
- Has O-ring groove

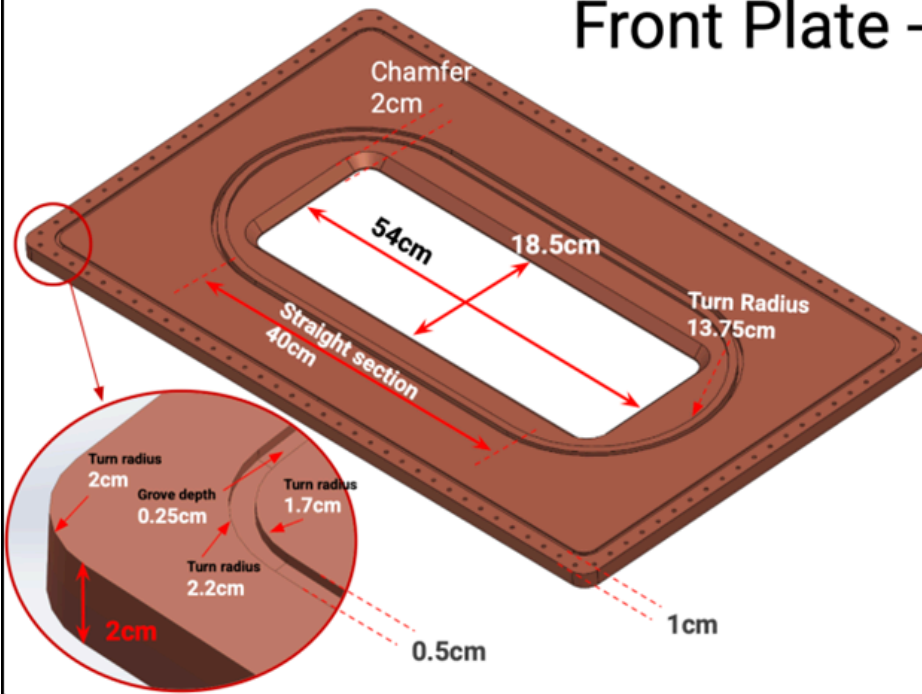

SS Bucket

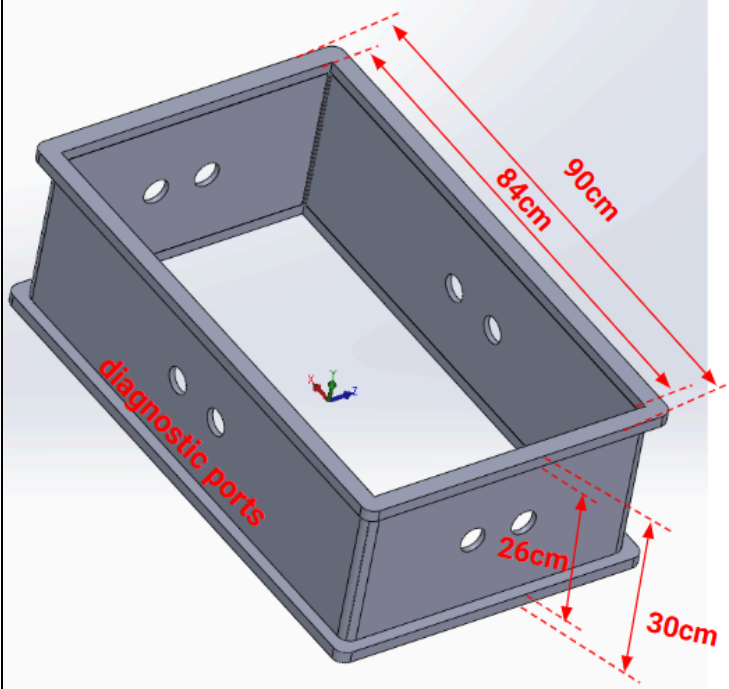

- 1cm thick wall
- Length: 84cm, width: 48cm
- Length: 90cm, width: 55cm
 - With the top and bottom lip
 - Lip houses the holes to mount to front and back plate
- Has 8 CF50 diagnostic ports
 - 6cm apart (side to side)
 - Center of the side on each side
 -

Back Plate - Also SS304

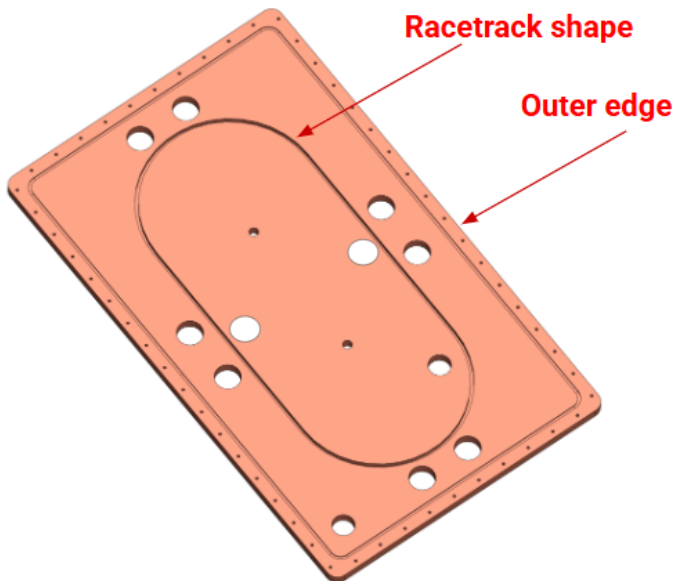

- Size and turn radius for the racetrack shape same as Front plate
- Groove 0.25cm deep for racetrack shape
- Groove depth for outer edge similar to front plate

Back Plate - Also SS304

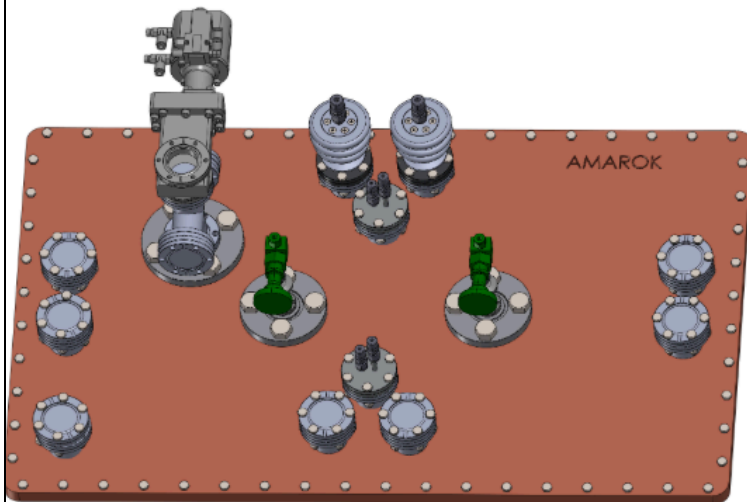

- Has CF40/CF50 ports with blanks
- The green gas valves has a small feedthrough for gas injection

4.0 Performance requirements

4.1. Leak rate	$\leq 7.5 \cdot 10^{-8}$ Torr-L/s
4.2. Bake-out Temperature	< 150 °C - 250 °C
4.3. Outgassing rate	$\leq 10^{-12}$ Torr-L/s/cm ²
4.4. Vibration induced fluctuations	$\leq 10^{-5}$ Torr

5.0 Support structure requirement

- 5.1. Need to be leak tight mountable to the diagnostic chamber through the defined interface bolt hole pattern
- 5.2. The structure should not hinder access to view ports or diagnostic ports.
- 5.3. Should have lifting eye bolts to hold in-place

6.0 Testing and Validation Requirements

- 6.1. The chamber should be tested for vacuum integrity and should have leak rate as stated in Sec. 4.1.

7.0 Documentation Requirements

The following documents are to be sent along with the chamber:

- 7.1. 3D CAD model documents in .STL or other 3D rendering format

- 7.2. Technical drawing of the chamber
- 7.3. Material certification if any
- 7.4. Leak check and rate certification

8.0 Delivery and installation

- 8.1. Delivery charges should be incurred by the supplier
- 8.2. Installation guide is required
- 8.3. Installation of the system on-site is optional but could be supported by the supplier.

INSTRUCTIONS TO BIDDERS

1. **READ, REVIEW AND COMPLY:** It shall be the bidder's responsibility to read this entire document, review all enclosures and attachments, and comply with all requirements specified herein.
2. **NOTICE TO BIDDERS:** All bids are subject to the provisions of the Instructions to Bidders, special terms and conditions specific to this Request for Quotation, the specifications, and the North Carolina State University General Contract Terms and Conditions. The University objects to and will not evaluate or consider any additional terms and conditions submitted with a bidder response. This applies to any language appearing in or attached to the document as part of the bidder's response. **DO NOT ATTACH ANY ADDITIONAL TERMS AND CONDITIONS.**
By execution and delivery of this document, the bidder agrees that any additional terms and conditions, whether submitted purposely or inadvertently, shall have no force or effect.
3. **BID SUBMITTAL:** NC State University uses a third-party eProcurement strategic sourcing provider, Bonfire, for accepting and evaluating bids digitally. All bids must be received by the issuing agency not later than the date and time listed on the cover sheet of this bid. Bids shall be uploaded to:

<https://ncsu.bonfirehub.com/opportunities/237883>

Solicitation documents are advertised on the State of North Carolina Electronic Vendor Portal System ([eVP](#)) and [Bonfire](#). An addendum to this RFQ may be issued. If required, any subsequent addenda must be signed and submitted with the bid upload. It is the **vendor's responsibility** to verify that all applicable addenda are submitted as required.

For support or technical questions related to your submission, please contact Bonfire at support.bonfire@eunasolutions.com or visit their help forum at <https://help.eunasolutions.com/hc/en-us>

4. **BONFIRE REQUESTED DOCUMENTATION & INFORMATION:** In an effort to support the sustainability efforts of the State of North Carolina we are receiving proposals via electronic submission. Bidder is to furnish all information requested and in the spaces provided in this document. Further, if required elsewhere in this bid, each bidder must submit with their bid sketches, descriptive literature and/or complete specifications covering the products offered. Reference to literature submitted with a previous bid will not satisfy this provision. Bids which do not comply with these requirements will be subject to rejection.

Please note the type and number of files allowed. The maximum upload file size is 1000 MB. Uploading large documents may take significant time, depending on the size of the file(s) and your Internet connection speed. Please do not embed any documents within your uploaded files, as they will not be accessible or evaluated. Minimum system requirements: Microsoft Edge, Google Chrome, or Mozilla Firefox. Javascript must be enabled. Browser cookies must be enabled.

Name	File Type	# of Files	Requirement
Completed NC State University Solicitation Document	PDF	1	Required
Addendum - if issued	PDF	1	

All documents required to complete your submission must be downloaded from the supporting documentation and/or requested information sections of Bonfire. You will receive an email confirmation receipt with a unique confirmation number once you finalize your submission. Each item of Requested Information will only be visible to NC State University after the Closing Time.

5. **DEFINITIONS:**

- **BIDDER:** Company, firm, corporation, partnership, individual, etc., submitting a response to an Invitation for Bids.
- **TERM CONTRACT:** A contract generally intended to cover all normal requirements for a commodity for a specified period of time based on estimated quantities only.
- **STATEWIDE TERM CONTRACT:** A Term Contract for all agencies, unless exempted by statute, rule, or special term and condition specific to this bid.
- **AGENCY SPECIFIC TERM CONTRACT:** A Term Contract for a specific agency.
- **OPEN MARKET CONTRACT:** A contract for the purchase of a commodity not covered by a term contract.

6. **EXECUTION:** Failure to sign under EXECUTION section will render bid invalid.
7. **ORDER OF PRECEDENCE:** In cases of conflict between specific provisions in this bid, the order of precedence shall be (1) special terms and conditions specific to this bid, (2) specifications, (3) North Carolina State University General Contract Terms and Conditions, and (4) Instructions to Bidders.
8. **TIME FOR CONSIDERATION:** Unless otherwise indicated on the first page of this document, bidder's offer shall be valid for 45 days from the date of bid opening. Preference may be given to bids allowing not less than 45 days for consideration and acceptance.
9. **PROMPT PAYMENT DISCOUNTS:** Bidders are urged to compute all discounts into the price offered. If a prompt payment discount is offered, it will not be considered in the award of the contract except as a factor to aid in resolving cases of identical prices.
10. **SPECIFICATIONS:** Any deviation from specifications indicated herein must be clearly pointed out; otherwise, it will be considered that items offered are in strict compliance with these specifications, and bidder will be held responsible therefore. Deviations shall be explained in detail. **The bidder shall not construe this paragraph as inviting deviation or implying that any deviation will be acceptable.**
11. **INFORMATION AND DESCRIPTIVE LITERATURE:** Bidder is to furnish all information requested and in the spaces provided in this document. Further, if required elsewhere in this bid, each bidder must submit with their bid sketches, descriptive literature and/or complete specifications covering the products offered. Reference to literature submitted with a previous bid will not satisfy this provision. Bids which do not comply with these requirements will be subject to rejection.
12. **RECYCLING AND SOURCE REDUCTION:** It is the policy of this State to encourage and promote the purchase of products with recycled content to the extent economically practicable, and to purchase items which are reusable, refillable, repairable, more durable, and less toxic to the extent that the purchase or use is practicable and cost-effective. We also encourage and promote using minimal packaging and the use of recycled/recyclable products in the packaging of commodities purchased. However, no sacrifice in quality of packaging will be acceptable. The company remains responsible for providing packaging that will protect the commodity and contain it for its intended use. Companies are strongly urged to bring to the attention of purchasers those products or packaging they offer which have recycled content and that are recyclable.
13. **CLARIFICATIONS/INTERPRETATIONS:** Any and all questions regarding this document must be addressed to the purchaser named on the cover sheet of this document. Do not contact the user directly. Any and all revisions to this document shall be made only by written addendum. The bidder is cautioned that the requirements of this bid can be altered only by written addendum and that verbal communications from whatever source are of no effect.
12. **ACCEPTANCE AND REJECTION:** The University reserves the right to reject any and all bids, to waive any informality in bids and, unless otherwise specified by the bidder, to accept any item in the bid. If a unit price or extended price is obviously in error and the other is obviously correct, the incorrect price will be disregarded.
15. **REFERENCES:** The University reserves the right to require a list of users of the exact item offered. The quote evaluators may contact these users to determine acceptability of the bid. Such information may be considered in the evaluation of the bid.
16. **TAXES:**
 - **FEDERAL:** All agencies participating in this contract are exempt from Federal Taxes, such as excise and transportation. Exemption is claimed under Registry No. 56-70-0047K as provided by Chapter 32 of the Internal Revenue Code.
 - **OTHER:** Prices offered are not to include any personal property taxes, nor any sales or use tax (or fees) unless required by the North Carolina Department of Revenue.
17. **AWARD OF CONTRACT:** As directed by statute, qualified bids will be evaluated and acceptance may be made of the lowest and best bid most advantageous to the University as determined upon consideration of such factors as: prices offered; the quality of the articles offered; the general reputation and performance capabilities of the bidders; the substantial conformity with the specifications and other conditions set forth in the bid; the suitability of the articles for the intended use; the related services needed; the date or dates of delivery and performance; and such other factors deemed by the University to be pertinent or peculiar to the purchase in question. Unless otherwise specified by the University or the bidder, the University reserves the right to accept any item or group of items on a multi-item bid. The University reserves the right to make partial, progressive or multiple awards: where it is advantageous to award separately by items; or where more than one supplier is needed to provide the contemplated requirements as to quantity, quality, delivery, service, geographical areas; other factors deemed by the University to be pertinent or peculiar to the purchase in question.
18. **HISTORICALLY UNDERUTILIZED BUSINESSES:** Pursuant to General Statute 143-48 and Executive Order #150, the University invites and encourages participation in this procurement process by businesses owned by minorities,

women, disabled, disabled business enterprises and non-profit work centers for the blind and severely disabled.

19. **CONFIDENTIAL INFORMATION:** Contractors should give specific attention to the identification of those portions of their proposals that they deem to be trade secrets and provide any justification why such materials, upon request, should not be disclosed. However, if the information you deem confidential is NOT a trade secret then the information will be released. The University may only keep information confidential to the extent permitted by NCAC T01:05B.1501 and G.S. 132-1.3.

Contractors shall clearly identify each and every section that is deemed to be confidential, proprietary or a trade secret (it is **NOT** sufficient to preface your proposal with a proprietary statement, or to use a page header or footer that arbitrarily marks **all** pages as confidential). Any individual section of the proposal that is not labeled as confidential with an accompanying statement concerning the rationale for its claimed confidentiality shall be considered public information.

CONFIDENTIALITY OF BIDS: In submitting its quote, the Bidder agrees not to discuss or otherwise reveal the contents of the quotes to any source outside of the University, until after the award of the contract. All Bidders are advised that they are not to have any communications with the using department during the evaluation of the bids (i.e., after the opening of the bids and before the award of the contract), unless the University's purchaser contacts the Bidder(s) for purposes of seeking clarification. A Bidder shall not: transmit to the using department any information commenting on the ability or qualifications of any other Bidder to provide the advertised good, equipment, commodity; defects, errors and/or omissions in any other Bidder's quote and/or prices at any time during the procurement process; and/or engage in any other communication or conduct attempting to influence the evaluation and/or award of the contract that is the subject of this RFQ. Bidders not in compliance with this provision may be disqualified, at the option of the University, from the contract award. Only those communications authorized by this RFQ are permitted.

20. **SAMPLES:** Sample of items, when required, must be furnished as stipulated herein, free of expense, and if not destroyed will, upon request be returned at the bidder's expense. Requests for the return of samples must be made within 10 days following date of bid opening. Otherwise the samples will become the University's property. Each individual sample must be labeled with the bidder's name, bid number, and item number. A sample on which an award is made, will be retained until the contract is completed, and then returned, if requested, as specified above.
21. **PROTEST PROCEDURES:** A party wanting to protest a contract award pursuant to this solicitation must submit a written request to the Director of Purchasing, North Carolina State University, Purchasing Department, Campus Box 7212, Raleigh, NC 27695-7212. This request must be received in the University Purchasing Department within thirty (30) consecutive calendar days from the date of the contract award, and must contain specific sound reasons and any supporting documentation for the protest. NOTE: Contract award notices are sent **only** to those actually awarded contracts, and not to every person or firm responding to this solicitation. Offerors may call the purchaser listed on the first page of this document to obtain a verbal status of contract award. All protests will be handled pursuant to the North Carolina Administrative Code, Title 1, Department of Administration, Chapter 5, Purchase and Contract, Section 5B.1519.
22. **MISCELLANEOUS:** Masculine pronouns shall be read to include feminine pronouns, and the singular of any word or phrase shall be read to include the plural and vice versa.
23. **RECIPROCAL PREFERENCE:** G.S. 143-59 establishes a reciprocal preference law to discourage other states from applying in-state preferences against North Carolina's resident bidders. The "Principal Place of Business" is defined as the principal place from which the trade or business of the bidder is directed or managed.
24. **ENTERPRISE-LEVEL IT SYSTEMS OR TECHNOLOGIES:** The University is committed to promote and integrate universal IT accessibility in the delivery of its resources and to develop innovative solutions to accessibility challenges for students, faculty and staff. Vendors must:
- a. Assure all features, components and subsystems of the software or IT System contained on this RFQ **fully comply** with Section 508 of the Rehabilitation Act of 1973, as amended (29 U.S.C. 794d), (<http://www.section508.gov>);
 - OR
 - Detail why any feature, component or sub-system contained in this RFQ does not **fully comply** with Section 508, and the way in which the proposed product is out of compliance;
 - b. If the Voluntary Product Accessibility Templates (VPAT) (<http://www.access-star.org/ITI-VPAT/v1.2.html>) are used, they must include compliance checklists for:
 1. Technical Standards,
 2. Function and Performance Criteria

3. Documentation and Support

c. The product offered in response to this RFQ is subject to an accessibility evaluation by the University.

NORTH CAROLINA STATE UNIVERSITY

GENERAL CONTRACT TERMS AND CONDITIONS

1. **GOVERNING LAW:** This contract is made under and shall be governed and construed in accordance with the laws of the State of North Carolina.
2. **SITUS:** The place of this contract, its situs and forum, shall be Wake County, North Carolina, where all matters, whether sounding in contract or tort, relating to its validity, construction, interpretation and enforcement shall be determined.
3. **DEFAULT AND PERFORMANCE BOND:** In case of default by the contractor, the University may procure the articles or services from other sources and hold the contractor responsible for any excess cost occasioned thereby. The University reserves the right to require performance bond or other acceptable alternative guarantees from successful bidder without expense to the University.

In addition, in the event of default by the Contractor under this contract, the State may immediately cease doing business with the Contractor, immediately terminate for cause all existing contracts the State has with the Contractor, and de-bar the Contractor from doing future business with the State.

Upon the Contractor filing a petition for bankruptcy or the entering of a judgment of bankruptcy by or against the Contractor, the State may immediately terminate, for cause, this contract and all other existing contracts the Contractor has with the State, and de-bar the Contractor from doing future business with the State.

4. **FORCE MAJEURE:** Neither party shall be deemed to be in default of its obligations hereunder if and so long as it is prevented from performing such obligations by an act of war, hostile foreign action, nuclear explosion, earthquake, hurricane, tornado, or other catastrophic natural event or act of God.
5. **GOVERNMENTAL RESTRICTIONS:** In the event any Governmental restrictions are imposed which necessitate alteration of the material, quality, workmanship or performance of the items offered prior to their delivery, it shall be the responsibility of the contractor to notify, in writing, the issuing purchasing office at once, indicating the specific regulation which required such alterations. The University reserves the right to accept any such alterations, including any price adjustments occasioned thereby, or to cancel the contract.
6. **AVAILABILITY OF FUNDS:** Any and all payments to the contractor are dependent upon and subject to the availability of funds to the agency for the purpose set forth in this agreement.
7. **TAXES:** Any applicable taxes shall be invoiced as a separate item.

G.S. 143-59.1 bars the Secretary of Administration from entering into contracts with vendors if the vendor or its affiliates meet one of the conditions of G. S. 105-164.8(b) and refuse to collect use tax on sales of tangible personal property to purchasers in North Carolina. Conditions under G. S. 105-164.8(b) include: (1) Maintenance of a retail establishment or office, (2) Presence of representatives in the State that solicit sales or transact business on behalf of the vendor and (3) Systematic exploitation of the market by media-assisted, media-facilitated, or media-solicited means. By execution of the bid document the vendor certifies that it and all of its affiliates, (if it has affiliates), collect(s) the appropriate taxes.

8. **INSPECTION AT CONTRACTOR'S SITE:** The University reserves the right to inspect, at a reasonable time, the equipment/item, plant or other facilities of a prospective contractor prior to contract award, and during the contract term as necessary for the University's determination that such equipment/item, plant or other facilities conform with the specifications/requirements and are adequate and suitable for the proper and effective performance of the contract.
9. **PAYMENT TERMS:** Payment terms are Net not later than 30 days after receipt of correct invoice or acceptance of goods, whichever is later. The University is responsible for all payments to the contractor under the contract. Payment may be made by procurement card and it shall be accepted by the contractor for payment if the contractor accepts that card (Visa, Mastercard, etc.) from other customers. If payment is made by procurement card, then payment may be processed immediately by the contractor.
10. **AFFIRMATIVE ACTION:** The contractor will take affirmative action in complying with all Federal and State requirements concerning fair employment and employment of people with disabilities, and concerning the treatment of all employees without regard to discrimination by reason of race, color, religion, sex, national origin or disability.

11. **CONDITION AND PACKAGING:** Unless otherwise provided by special terms and conditions or specifications, it is understood and agreed that any item offered or shipped has not been sold or used for any purpose and shall be in first class condition. All containers/packaging shall be suitable for handling, storage or shipment.
12. **PATENT:** The contractor shall hold and save the University, its officers, agents and employees, harmless from liability of any kind, including costs and expenses, on account of any copyrighted material, patented or unpatented invention, articles, device or appliance manufactured or used in the performance of this contract, including use by the government.
13. **ADVERTISING:** Contractor shall not use the existence of this contract or the name of the State of North Carolina or North Carolina State University as part of any advertising.
14. **ACCESS TO PERSONS AND RECORDS:** The State or University auditor, or the Joint Commission on Governmental Operations and legislative employees whose primary responsibility is to provide professional or administrative services to the Commission, may audit the records of contractor during and after the term of this Agreement to verify accounts and data affecting fees or performance in accordance with North Carolina General Statutes §143-49(9) and §147-64.7 and Session Law 2023-134.
15. **ASSIGNMENT:** No assignment of the contractor's obligations nor the contractor's right to receive payment hereunder shall be permitted.
However, upon written request approved by the issuing purchasing authority and solely as a convenience to the contractor, the University may:
 - a. Forward the contractor's payment check directly to any person or entity designated by the contractor, and b. Include any person or entity designated by contractor as a joint payee on the contractor's payment check. In no event shall such approval and action obligate the State to anyone other than the contractor and the contractor shall remain responsible for fulfillment of all contract obligations.
16. **INSURANCE:**
 - COVERAGE** - During the term of the contract, the contractor at its sole cost and expense shall provide commercial insurance of such type and with such terms and limits as may be reasonably associated with the contract. As a minimum, the contractor shall provide and maintain the following coverage and limits:
 - a. **Worker's Compensation** - The contractor shall provide and maintain Worker's Compensation Insurance, as required by the laws of North Carolina, as well as employer's liability coverage with minimum limits of \$500,000.00, covering all of contractor's employees who are engaged in any work under the contract. If any work is sublet, the contractor shall require the subcontractor to provide the same coverage for any of his employees engaged in any work under the contract.
 - b. **Commercial General Liability** - General Liability Coverage on a Comprehensive Broad Form on an occurrence basis in the minimum amount of \$1,000,000.00 Combined Single Limit. (Defense cost shall be in excess of the limit of liability.)
 - c. **Automobile** - Automobile Liability Insurance, to include liability coverage, covering all owned, hired and non-owned vehicles, used in connection with the contract. The minimum combined single limit, on a per occurrence basis shall be \$1,000,000.00 bodily injury and property damage; \$1,000,000.00 uninsured/underinsured motorist; and \$1,000.00 medical payment.
 - REQUIREMENTS:** Providing and maintaining adequate insurance coverage is a material obligation of the contractor and is of the essence of this contract. All such insurance shall meet all laws of the State of North Carolina. Such insurance coverage shall be obtained from companies that are authorized to provide such coverage and that are authorized by the Commissioner of Insurance to do business in North Carolina. The contractor shall at all times comply with the terms of such insurance policies, and all requirements of the insurer under any such insurance policies, except as they may conflict with existing North Carolina laws or this contract. The limits of coverage under each insurance policy maintained by the contractor shall not be interpreted as limiting the contractor's liability and obligations under the contract.
17. **GENERAL INDEMNITY:** The contractor shall hold and save the State, its officers, agents, and employees, harmless from liability of any kind, including all claims and losses accruing or resulting to any other person, firm, or corporation furnishing or supplying work, services, materials, or supplies in connection with the performance of this contract, and from any and all claims and losses accruing or resulting to any person, firm, or corporation that may be injured or damaged by the contractor in the performance of this contract and that are attributable to the negligence or intentionally tortious acts of the contractor provided that the contractor is notified in writing within 30 days that the State has knowledge of such claims. The contractor represents and warrants that it shall make no claim of any kind or nature against the State's agents who are involved in the delivery or processing of contractor goods to the State. The representation and warranty in the preceding sentence shall survive the termination or expiration of this contract.
18. **CANCELLATION (TERM CONTRACTS ONLY):** All contract obligations shall prevail for at least 90 days after the effective date of the contract. After that period, in addition to the provisions of the paragraph entitled Price Adjustments, for the protection of both parties, this contract may be canceled in whole or in part by either party by giving 30 days prior notice in writing to the other party.

19. **QUANTITIES (University Specific Agreements ONLY):** The award of a University specific agreement neither implies nor guarantees any minimum or maximum purchases thereunder.
20. **PRICE ADJUSTMENTS (TERM CONTRACTS ONLY):** Any price changes, downward or upward, which might be permitted during the contract period must be general, either by reason of market change or on the part of the contractor to other customers.
- a. **Notification:** Must be given to the University, in writing, concerning any proposed price adjustments. Such notification shall be accompanied by copy of manufacturer's official notice or other acceptable evidence that the change is general in nature.
- b. **Decreases:** The University shall receive full proportionate benefit immediately at any time during the contract period.
- c. **Increases:** All prices shall be firm against any increase for 180 days from the effective date of the contract. After this period, a request for increase may be submitted with the University reserving the right to accept or reject the increase, or cancel the contract. Such action by the University shall occur not later than 15 days after the receipt by the University of a properly documented request for price increase. Any increases accepted shall become effective not later than 30 days after the expiration of the original 15 days reserved to evaluate the request for increase.
- d. **Invoices:** It is understood and agreed that orders will be shipped at the established contract prices in effect on dates orders are placed. Invoicing at variance with this provision will subject the contract to cancellation. Applicable North Carolina sales tax shall be invoiced as a separate item.
21. **SAFETY STANDARDS:** All manufactured items and/or fabricated assemblies subject to operation under pressure, operation by connection to an electric source, or operation involving a connection to a manufactured, natural, or LP gas source shall be constructed and approved in a manner acceptable to the appropriate state inspector which customarily requires the label or re examination listing or identification marking of the appropriate safety standard organization, such as the American Society of Mechanical Electrical Engineers for pressure vessels; the Underwriters' Laboratories and/or National Electrical Manufacturers' Association for electrically operated assemblies; or the American Gas Association for gas operated assemblies, where such approvals of listings have been established for the type(s) of devices offered and furnished. Further, all items furnished by the successful bidder shall meet all requirements of the Occupational Safety and Health Act (OSHA), and state and federal requirements relating to clean air and water pollution.

All contractors must comply with *North Carolina Occupational Safety and Health Standards for General Industry, 29CFR 1910*. Construction contractors must comply with *North Carolina Occupational Safety and Health Standards for the Construction Industry, 29CFR 1926*. In addition, contractors shall comply with all applicable occupational health and safety and environmental rules and regulations.

Contractors shall effectively manage their safety and health responsibilities including:

1. Accident Prevention

Prevent injuries and illnesses to their employees and others on or near their job site. Contractor managers and supervisors shall ensure employer's personnel safety by strict adherence to established safety rules and procedures.

2. Environmental Protection

Protect the environment on, near, and around their work site by compliance with all applicable environmental regulations.

3. Employee Education and Training

Provide education and training to all contractors employees before they are exposed to potential workplace or other hazards as required by specific OSHA Standards.

The complete product(s) offered herein, and NOT merely its component parts or subsystems, must comply with the above requirement for safety listing. Having the appropriate certification or safety label affixed to any device delivered pursuant to this solicitation, under the conditions described above, is a material condition of any contract awarded as a result of this solicitation. All costs for product and industry certifications and listings, and any other actions required to supply conforming products to the State as described in this IFB, are the sole responsibility of the Vendor. The certification or safety label shall be affixed and be visible on the OUTSIDE of all products that require a certification or safety label in order to pass the State Quality Acceptance Inspection.

22. **DEBARMENT CERTIFICATION:** Offeror certifies to the best of its knowledge and belief, that it nor any of its principals a) are not presently debarred, suspended, proposed for debarment, or declared ineligible for the award of contract by any Federal agency; b) have not within a three year period preceding this award been convicted of or had a civil judgment rendered against them for: commission of a fraud or a criminal offense in connection with obtaining, attempting to obtain, or performing a public (Federal, state or local) contract or subcontract; violation of Federal or state

antitrust statutes relating to this submission of offers; or commission of embezzlement, theft, forgery, bribery, falsifications or destruction of records, making false statements, or receiving stolen property; and c) are not presently indicted for, or otherwise criminally or civilly charged by a government entity with, commission of any of these offenses enumerated herein. The offer certifies that they have not, within a three year period preceding this offer, had one or more contracts terminated for default by any federal agency.

“Principals” for the purpose of this certification, means officers; directors; owners; partners; and persons having primary management or supervisory responsibilities within a business entity (e.g., general manager; plant manager; head of a subsidiary, division, or business segments, and similar positions.)

This certification concerns a matter within the jurisdiction of an agency of the United States and the making of a false, fictitious, or fraudulent certification may render the maker subject to prosecution. Certification of this provision is a material representation of fact upon which reliance was placed when making an award. If it is later determined that the Offeror knowingly rendered an erroneous certification, in addition to other remedies available to the University, the University may terminate this agreement for default.

Offeror hereby certifies these conditions and does so by signing the execution page of this quote document.

23. **PERSONAL IDENTIFIERS:** If the University provides the Contractor with personal identifiers as listed in North Carolina General Statute 131-1.10 or any other legally confidential information, Contractor hereby certifies that, pursuant to NCGS 132-1.10, collection of social security number information or other legally confidential information from University is necessary for the performance of Contractor duties and responsibilities on behalf of the University. Contractor further certifies that it shall maintain the confidential and exempt status of any such social security number information, as required by subsection (c)(1) of the statute.
24. **GIFTS:** Pursuant to Executive Order 24, issued by Governor Perdue, and N.C. G.S. § 133-32, it is unlawful for any vendor or contractor, including, but not limited to, architect, bidder, contractor, construction manager, design professional, engineer, landlord, offeror, seller, subcontractor, supplier, or vendor, to make gifts or to give favors to any State employee of the Office of the Governor and Governor’s Cabinet Agencies. This prohibition covers those vendors and contractors who:
- (1) Have a contract with a governmental agency; or
 - (2) Have performed under such a contract within the past year; or
 - (3) Anticipate bidding on such a contract in the future.

For additional information regarding the specific requirements and exemptions, vendors and contractors are encouraged to review Executive Order 24 and G.S. Sec. 133-32.

25. **IRAN DIVESTMENT ACT -CERTIFICATION AND ONGOING OBLIGATIONS:** The NC General Assembly recently enacted the Iran Divestment Act (S.L. 2015-118). This requirement applies to all units of State government and to all political subdivisions of the State. The Iran Divestment Act List is a list published by the North Carolina Department of State Treasurer pursuant to the requirements of this Act that identifies persons engaged in investment activities in Iran. Currently, the list is available at the following URL: <https://www.nctreasurer.com/inside-the-department/OpenGovernment/Pages/Iran-Divestment-Act-Resources.aspx>.

By accepting an order from the University, the Contractor certifies that, as of the date of acceptance, it is not on the then current version of the Iran Divestment Act List. Contractor agrees to not contract with any person to perform a part of the contractual work, if, at the time the Contractor enters into a subcontract, that person is on the then-current version of the Iran Divestment Act List. Contractor further agrees to notify the Procurement Specialist if, at any time during the contract term, including any renewal terms, it is added to the Iran Divestment Act List.

NORTH CAROLINA STATE UNIVERSITY
GENERAL CONTRACT TERMS AND CONDITIONS
(Contractual and Consultant Services)

1. **GOVERNING LAW:** This contract is made under and shall be governed and construed in accordance with the laws of the State of North Carolina.
2. **SITUS:** The place of this contract, its situs and forum, shall be Wake County, North Carolina, where all matters, whether sounding in contract or tort, relating to its validity, construction, interpretation and enforcement shall be determined.
3. **INDEPENDENT CONTRACTOR:** The Contractor shall be considered to be an independent contractor and as such shall be wholly responsible for the work to be performed and for the supervision of its employees. The Contractor represents that it has, or will secure at its own expense, all personnel required in performing the services under this agreement. Such employees shall not be employees of, or have any individual contractual relationship with the Agency.
4. **KEY PERSONNEL:** The Contractor shall not substitute key personnel assigned to the performance of this contract without prior written approval by the University's Contract Administrator. The individuals designated as key personnel for purposes of this contract are those specified in the Contractor's proposal.
5. **BACKGROUND CHECKS:** The Supplier shall, at no additional cost to the University, secure appropriate background checks for all employees to be assigned to any resulting contract. These background checks shall include criminal conviction and sex offender checks at a minimum. These background checks shall be maintained by the supplier and are subject to audit by appropriate University or state officials at any time during and for five (5) years after the contract end date. NC State may withhold consent for any of Supplier's employees to be placed on a University assignment at its sole discretion. The Supplier shall immediately (same day as notification) remove any employee from NC State property that the University deems unfit for any reason.
6. **SUBCONTRACTING:** Work proposed to be performed under this contract by the Contractor or its employees shall not be subcontracted without prior written approval of the University's Contract Administrator. Acceptance of an offeror's proposal shall include any subcontractor(s) specified therein.
7. **PERFORMANCE AND DEFAULT:** If, through any cause, the Contractor shall fail to fulfill in timely and proper manner the obligations under this agreement, the University shall thereupon have the right to terminate this contract by giving written notice to the Contractor and specifying the effective date thereof. In that event, all finished or unfinished deliverable items under this contract prepared by the Contractor shall, at the option of the University, become its property, and the Contractor shall be entitled to receive just and equitable compensation for any satisfactory work completed on such materials. Notwithstanding, the Contractor shall not be relieved of liability to the University for damages sustained by the University by virtue of any breach of this agreement, and the University may withhold any payment due the Contractor for the purpose of setoff until such time as the exact amount of damages due the University from such breach can be determined.

In case of default by the Contractor, the University may procure the services from other sources and hold the Contractor responsible for any excess cost occasioned thereby. The University reserves the right to require performance bond or other acceptable alternative guarantees from successful offeror without expense to the University.

In addition, in the event of default by the Contractor under this contract, the State may immediately cease doing business with the Contractor, immediately terminate for cause all existing contracts the State has with the Contractor, and de-bar the Contractor from doing future business with the State.

Upon the Contractor filing a petition for bankruptcy or the entering of a judgment of bankruptcy by or against the Contractor, the University may immediately terminate, for cause, this contract and all other existing contracts the Contractor has with the University.

Neither party shall be deemed to be in default of its obligations hereunder if and so long as it is prevented from performing such obligations by any act of war, hostile foreign action, nuclear explosion, riot, strikes, civil insurrection, earthquake, hurricane, tornado, or other catastrophic natural event or act of God.

8. **FORCE MAJEURE:** Neither party shall be deemed to be in default of its obligations hereunder if and so long as it is prevented from performing such obligations by an act of war, hostile foreign action, nuclear explosion, earthquake, hurricane, tornado, or other catastrophic natural event or act of God.

9. **TERMINATION:** The University may terminate this agreement at any time by providing written notice to the contractor at least thirty (30) days before the effective date of the termination. In that event, all finished or unfinished deliverable items prepared by the Contractor under this contract shall, at the option of the University, become its property. If the contract is terminated by the University as provided herein, the Contractor shall be paid for services satisfactorily completed, less payment or compensation previously made. All promises, requirements, terms, conditions, provisions, representations, guarantees, and warranties contained herein shall survive the contract expiration or termination date unless specifically provided otherwise herein, or unless superseded by applicable Federal or State statutes of limitations.
10. **PAYMENT TERMS:** Payment terms are Net not later than 30 days after receipt of correct invoice or acceptance of goods, whichever is later. The University is responsible for all payments to the contractor under the contract. Payment may be made by procurement card and it shall be accepted by the contractor for payment if the contractor accepts that card (Visa, Mastercard, etc.) from other customers. If payment is made by procurement card, then payment may be processed immediately by the contractor.
11. **AVAILABILITY OF FUNDS:** Any and all payments to the Contractor are dependent upon and subject to the availability of funds to the University for the purpose set forth in this agreement.
12. **CONFIDENTIALITY:** Any information, data, instruments, documents, studies or reports given to or prepared or assembled by the Contractor under this agreement shall be kept as confidential and not divulged or made available to any individual or organization without the prior written approval of the Agency.
13. **CARE OF PROPERTY:** The Contractor agrees that it shall be responsible for the proper custody and care of any property furnished it for use in connection with the performance of this contract or purchased by it for this contract and will reimburse the State for loss of damage of such property.
14. **COPYRIGHT:** No deliverable items produced in whole or in part under this agreement shall be the subject of an application for copyright by or on behalf of the Contractor.

Copyright in and to any copyrightable work, including, but not limited to, copy, art, negatives, photographs, designs, text, software, or documentation created as part of Contractor's provision of Services shall vest in NC State. Works of authorship and contributions to works of authorship created by Contractor in connection with its provision of Services are hereby agreed to be "works made for hire" within the meaning of 17 U.S.C. 201. However, if NC State is not able to obtain copyright ownership under the statutory provisions for "works made for hire," then Contractor hereby assigns to NC State all right, title, and interest in such works and contributions.

Contractor agrees to provide NC State with any and all reasonable assistance which NC State may require to file patent applications, to obtain copyright registrations, or to perfect its title in any such inventions or works, including the execution of any documents submitted by NC State.

Contractor warrants that its Services do not infringe the copyright of others and agrees to release, discharge and hold harmless NC State, its employees and agents, all persons acting under its authority, and those for whom it is acting, from all claims, causes of action and liability of any kind, in law or equity, based upon or arising out of the Services or this Agreement including, without limitation, claims of libel, slander, invasion of privacy, right of publicity, defamation, trademark infringement, and copyright infringement.

No deliverable items produced in whole or in part under this agreement shall be the subject of an application for copyright by or on behalf of the Contractor.

15. **ACCESS TO PERSONS AND RECORDS:** The State or NC State auditor, or the Joint Commission on Governmental Operations and legislative employees whose primary responsibility is to provide professional or administrative services to the Commission, may audit the records of contractor during and after the term of this Agreement to verify accounts and data affecting fees or performance in accordance with North Carolina General Statutes §143-49(9) and §147-64.7 and Session Law 2023-134.
16. **ASSIGNMENT:** No assignment of the Contractor's obligations nor the Contractor's right to receive payment hereunder shall be permitted. However, upon written request approved by the issuing purchasing authority, the University may: a. Forward the contractor's payment check(s) directly to any person or entity designated by the Contractor, or b. Include any person or entity designated by Contractor as a joint payee on the Contractor's payment check(s). In no event shall such approval and action obligate the University to anyone other than the Contractor and the Contractor shall remain responsible for fulfillment of all contract obligations.

17. **COMPLIANCE WITH LAWS:** The Contractor shall comply with all laws, ordinances, codes, rules, regulations, and licensing requirements that are applicable to the conduct of its business, including those of federal, state, and local agencies having jurisdiction and/or authority.
18. **AFFIRMATIVE ACTION:** The Contractor shall take affirmative action in complying with all Federal and State requirements concerning fair employment and employment of people with disabilities, and concerning the treatment of all employees without regard to discrimination by reason of race, color, religion, sex, national origin, or disability.
19. **INSURANCE:** During the term of the contract, the contractor at its sole cost and expense shall provide commercial insurance of such type and with such terms and limits as may be reasonably associated with the contract. As a minimum, the contractor shall provide and maintain the following coverage and limits:
- a. Worker's Compensation - The contractor shall provide and maintain Worker's Compensation Insurance, as required by the laws of North Carolina, as well as employer's liability coverage with minimum limits of \$500,000.00, covering all of Contractor's employees who are engaged in any work under the contract. If any work is subcontracted, the contractor shall require the subcontractor to provide the same coverage for any of its employees engaged in any work under the contract.
 - b. Commercial General Liability - General Liability Coverage on a Comprehensive Broad Form on an occurrence basis in the minimum amount of \$1,000,000.00 Combined Single Limit. (Defense cost shall be in excess of the limit of liability).
 - c. Automobile - Automobile Liability Insurance, to include liability coverage, covering all owned, hired and non-owned vehicles, used in connection with the contract. The minimum combined single limit, on a per occurrence basis shall be \$1,000,000.00 bodily injury and property damage; \$1,000,000.00 uninsured/underinsured motorist; and \$1,000.00 medical payment.

Providing and maintaining adequate insurance coverage is a material obligation of the contractor and is of the essence of this contract. All such insurance shall meet all laws of the State of North Carolina. Such insurance coverage shall be obtained from companies that are authorized to provide such coverage and that are authorized by the Commissioner of Insurance to do business in North Carolina. The contractor shall at all times comply with the terms of such insurance policies, and all requirements of the insurer under any such insurance policies, except as they may conflict with existing North Carolina laws or this contract. The limits of coverage under each insurance policy maintained by the contractor shall not be interpreted as limiting the contractor's liability and obligations under the contract.

20. **ADVERTISING:** Contractor shall not use the existence of this contract or the name of the State of North Carolina or North Carolina State University as part of any advertising.
21. **ENTIRE AGREEMENT:** This contract and any documents incorporated specifically by reference represent the entire agreement between the parties and supersede all prior oral or written statements or agreements. This Request for Quote, any addenda thereto, and the offeror's response are incorporated herein by reference as though set forth verbatim.
- All promises, requirements, terms, conditions, provisions, representations, guarantees, and warranties contained herein shall survive the contract expiration or termination date unless specifically provided otherwise herein, or unless superseded by applicable Federal or State statutes of limitation.
22. **AMENDMENTS:** This contract may be amended only by written amendments duly executed by the University and the Contractor.
23. **TAXES:** G.S. 143-59.1 bars the Secretary of Administration from entering into contracts with vendors if the vendor or its affiliates meet one of the conditions of G. S. 105-164.8(b) and refuse to collect use tax on sales of tangible personal property to purchasers in North Carolina. Conditions under G. S. 105-164.8(b) include: (1) Maintenance of a retail establishment or office, (2) Presence of representatives in the State that solicit sales or transact business on behalf of the vendor and (3) Systematic exploitation of the market by media-assisted, media-facilitated, or media-solicited means. By execution of the bid document the vendor certifies that it and all of its affiliates, (if it has affiliates), collect(s) the appropriate taxes.
24. **GENERAL INDEMNITY:** The contractor shall hold and save the University, its officers, agents, and employees, harmless from liability of any kind, including all claims and losses accruing or resulting to any other person, firm, or corporation furnishing or supplying work, services, materials, or supplies in connection with the performance of this contract, and from any and all claims and losses accruing or resulting to any person, firm, or corporation that may be injured or damaged by the contractor in the performance of this contract and that are attributable to the negligence or intentionally tortious acts of the contractor provided that the contractor is notified in writing within 30 days that the State has knowledge of such claims. The

contractor represents and warrants that it shall make no claim of any kind or nature against the University's agents who are involved in the delivery or processing of contractor goods to the University. The representation and warranty in the preceding sentence shall survive the termination or expiration of this contract.

25. **OUTSOURCING:** Any vendor or subcontractor providing call or contact center services to the University or State of North Carolina shall disclose to inbound callers the location from which the call or contact center services are being provided.

If, after award of a contract, the contractor wishes to outsource any portion of the work to a location outside the United States, prior written approval must be obtained from the University agent responsible for the contract.

Vendor must give notice to the University of any relocation of the vendor, employees of the vendor, subcontractors of the vendor, or other persons performing services under a state contract outside of the United States.

26. **DEBARMENT CERTIFICATION:** Offeror certifies to the best of its knowledge and belief, that it nor any of its principals a) are not presently debarred, suspended, proposed for debarment, or declared ineligible for the award of contract by any Federal agency; b) have not within a three year period preceding this award been convicted of or had a civil judgment rendered against them for: commission of a fraud or a criminal offense in connection with obtaining, attempting to obtain, or performing a public (Federal, state or local) contract or subcontract; violation of Federal or state antitrust statutes relating to this submission of offers; or commission of embezzlement, theft, forgery, bribery, falsifications or destruction of records, making false statements, or receiving stolen property; and c) are not presently indicted for, or otherwise criminally or civilly charged by a government entity with, commission of any of these offenses enumerated herein. The offer certifies that they have not, within a three year period preceding this offer, had one or more contracts terminated for default by any federal agency.

"Principals" for the purpose of this certification, means officers; directors; owners; partners; and persons having primary management or supervisory responsibilities within a business entity (e.g., general manager; plant manager; head of a subsidiary, division, or business segments, and similar positions.)

This certification concerns a matter within the jurisdiction of an agency of the United States and the making of a false, fictitious, or fraudulent certification may render the maker subject to prosecution. Certification of this provision is a material representation of fact upon which reliance was placed when making an award. If it is later determined that the Offeror knowingly rendered an erroneous certification, in addition to other remedies available to the University, the University may terminate this agreement for default.

Offeror hereby certifies these conditions and does so by signing the execution page of this quote document.

27. **PERSONAL IDENTIFIERS:** If the University provides the Contractor with personal identifiers as listed in North Carolina General Statute 131-1.10 or any other legally confidential information, Contractor hereby certifies that, pursuant to NCGS 132-1.10, collection of social security number information or other legally confidential information from University is necessary for the performance of Contractor duties and responsibilities on behalf of the University. Contractor further certifies that it shall maintain the confidential and exempt status of any such social security number information, as required by subsection (c)(1) of the statute.

28. **IRAN DIVESTMENT ACT -CERTIFICATION AND ONGOING OBLIGATIONS:** The NC General Assembly recently enacted the Iran Divestment Act (S.L. 2015-118). This requirement applies to all units of State government and to all political subdivisions of the State. The Iran Divestment Act List is a list published by the North Carolina Department of State Treasurer pursuant to the requirements of this Act that identifies persons engaged in investment activities in Iran. Currently, the list is available at the following URL: <https://www.nctreasurer.com/inside-the-department/OpenGovernment/Pages/Iran-Divestment-Act-Resources.aspx>.

By accepting an order from the University, the Contractor certifies that, as of the date of acceptance, it is not on the then current version of the Iran Divestment Act List. Contractor agrees to not contract with any person to perform a part of the contractual work, if, at the time the Contractor enters into a subcontract, that person is on the then-current version of the Iran Divestment Act List. Contractor further agrees to notify the Procurement Specialist if, at any time during the contract term, including any renewal terms, it is added to the Iran Divestment Act List.

REFERENCES

OFFERORS MUST PROVIDE THREE (3) REFERENCES FOR WHOM THEY HAVE PERFORMED SIMILAR WORK IN THE PAST THREE (3) YEARS.

#1	Company Name:	
	Contact Name:	
	Email Address:	
	Telephone Number:	

#2	Company Name:	
	Contact Name:	
	Email Address:	
	Telephone Number:	

#3	Company Name:	
	Contact Name:	
	Email Address:	
	Telephone Number:	

THIS PAGE MUST BE COMPLETED AND SUBMITTED AS A PART OF YOUR QUOTATION.

