ADDENDUM NO. 2 TO BID DOCUMENTS

Date: May 27, 2025
Project: Utley Creek WRF - Lab & Operators Building
Owner: Town of Holly Springs
Engineer: Hazen and Sawyer

To All Bidders:

Contractors submitting Proposals for the above-named Project shall take note of the following changes, additions, deletions, clarifications, etc., in the Bid Documents, which shall become part of and have precedence over anything contrarily shown or described in the Bid Documents, and all such shall be taken into consideration and be included in the Contractor's Bid Proposal.

All other general items, conditions, drawings, and specifications shall remain the same. Please acknowledge the receipt of Addendum No. 2 with the Bid Form.

Refer to the Attached Sheets.

The return receipt requested with the communication will be deemed evidence that the bidder has received this Addendum and has followed the instructions outlined herein. Please sign, date, clearly print company name, and email this sheet back to Hazen and Sawyer at tohs_ucwrf_labopsbldg@hazenandsawyer.com.

Company Name

Acknowledgement of Receipt

Date



Michelle A. Mayes, P.E.
HAZEN AND SAWYER

Utlely Creek WRF - Lab & Operators Building Project

Addendum No. 2

GENERAL:

- Non-mandatory Pre-Bid Meeting slides and sign-in sheet are provided as **Attachment #1**.
- Response to Bidder Questions:
 1. Please clarify which MWBE forms should be submitted with the bid?
 - a. **Response:** Specific instructions regarding the Town's MWBE program area located in section 00905, page 00905-4 and 00905-5, paragraphs (a) through (k).
See below for clarification on which forms to submit with bid.

MWBE FORMS TO SUBMIT WITH BID

00905-8 (Intent to perform the Contract with own workforce Affidavit, if applicable)

-OR-

Both of the following:

00905-9 and 10 (Good Faith Efforts Affidavit)

00905-15 (Identification of Minority Business Participation)

MWBE FORMS TO SUBMIT POST-BID (by lowest responsive responsible bidder), BEFORE CONTRACT EXECUTION

If 10% minority business participation goal is met or exceeded, then submit:
00905-11 and 12 (Portion of the Work to be performed by Minority Firms)

-OR-

If 10% minority business participation goal is NOT met, then submit:
00905-13 and 14 (Documented Good Faith Efforts)

2. Is material and labor included in the allowance amounts?
 - a. **Response:** The allowances are for materials only.
3. Can the CAD files be made available?
 - a. **Response:** CAD files will be made available upon request. Bidders interested in receiving the CAD files shall sign and return the *Hazen Electronic Tile Transfer Form – CAD/BIM (Attachment #6)* to tohs_ucwrf_labopsbldg@hazenandsawyer.com.
4. Please confirm the mechanical controls vendor mentioned in the pre-bid meeting?

- a. **Response:** Section 23 09 02 of the Project Manual states the HVAC Automatic Temperature Controls (ATC) contractor shall be CMS Controls of Raleigh, NC.

SPECIFICATIONS:

SECTION 26 36 23 – AUTOMATIC TRANSFER SWITCHES

Add **Attachment #2** to the Project Manual.

DRAWINGS:

- C100 Revise Note 6 to the following: “SEE C005 FOR BOUNDARY AND PROJECT CONTROL INFORMATION.”
- C700 Revise Note 9 to the following: “REFER TO C800s FOR WATER MAIN PLAN AND PROFILES.”
- C008 See Revised Drawing C008 for updated storm and headwall structure schedules (**Attachment #3**).
- E302 Sheet E003 shall be updated as shown in **Attachment #4**.
- E303 Sheet E809 shall be updated as shown in **Attachment #5**.

ATTACHMENTS:

- Attachment #1: Pre-bid Meeting Slides and Sign-in sheet
- Attachment #2: Section 26 36 23 – Automatic Transfer Switches
- Attachment #3: Revised sheet (C008)
- Attachment #4: Updated callout for Generator Pad (Sheet E003)
- Attachment #5: Updates to Single Line Diagram and Notes for Load Shedding (Sheet E809)
- Attachment #6: Hazen Electronic Tile Transfer Form – CAD/BIM

**Presentation Slides are for
Reference Only
Bid Documents &
Addendum Are Binding**

Hazen



UCWRF – Lab & Operators Building Pre-Bid Meeting May 21, 2025

Presentation for Reference Only – Bid Documents Govern

Meeting Agenda

- Introductions
- Bid / Project Schedule
- Contract Documents
- UCWRF Lab & Ops Bldg (Description of Project / Summary of Work)
- Coordination with Owner's Operations
- Bid Requirements
- Questions
- Site visit

Welcome and Introductions

- Owner: Town of Holly Springs
 - Executive Director of Utilities and Infrastructure: Kendra D Parrish
 - Deputy Director of Utilities and Infrastructure – Water Resources: Rachel Ingham
 - Utilities Manager – Water Facility Operations: Terry Foster
- Engineer: Hazen and Sawyer
 - Project Manager: David Wankmuller
 - Design Manager: Michelle Mayes

Bid / Project Schedule

- Advertisement: May 09, 2025
- Pre-Bid Meeting: May 21, 2025
- Bid Opening Date: Thursday, June 10, 2025, 2:00PM

LGC Application and Approval

Town Council Approval

- Anticipated Notice of Award: August 2025
- Construction Duration
 - *120 days for Clearing, Grub, Grading, Erosion & Sedimentation Basins*
 - *270 days for Duct Bank and Temporary Roads*
 - *510 days to Substantial Completion*
 - *540 days to Final Completion*

Contract Documents and Addenda – Contact Information

- Contract Documents can be obtained from the Town bid page: [Bids & Requests for Proposals | Holly Springs, NC - Official Website](#)
- Electronic documents provided at no charge
- All questions about the meaning or intent of the Bid Document or Contract Documents shall be submitted to Engineer in writing. Email questions to: tohs_ucwrf_labopsbldg@hazenandsawyer.com
- Addenda will be posted to the Town bid page
 - Bidders required to acknowledgement of addendum on the bid forms
- Deadline for questions is 5:00 p.m. on May 30, 2025
- Last addenda will be issued no later than June 3, 2025

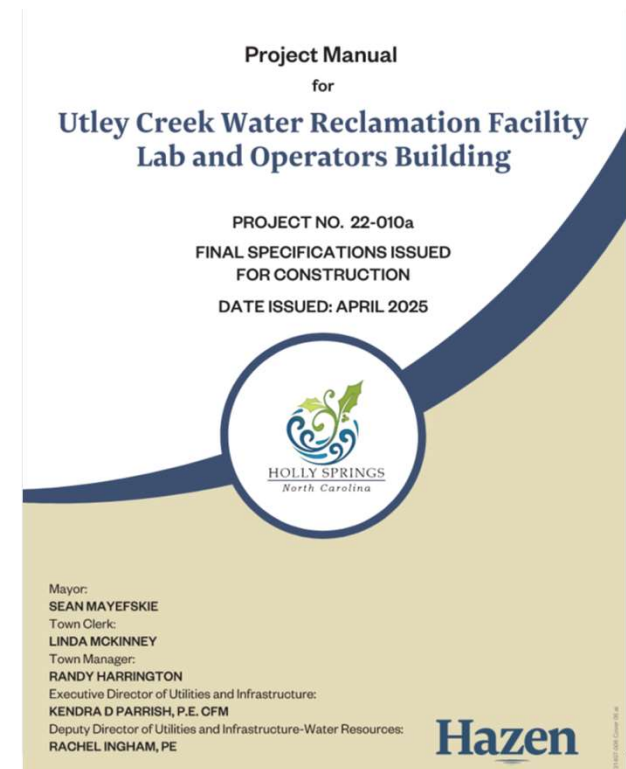

Project Overview

Project Location

Utley Creek WRF

150 Treatment Plant Rd, Holly Springs, NC

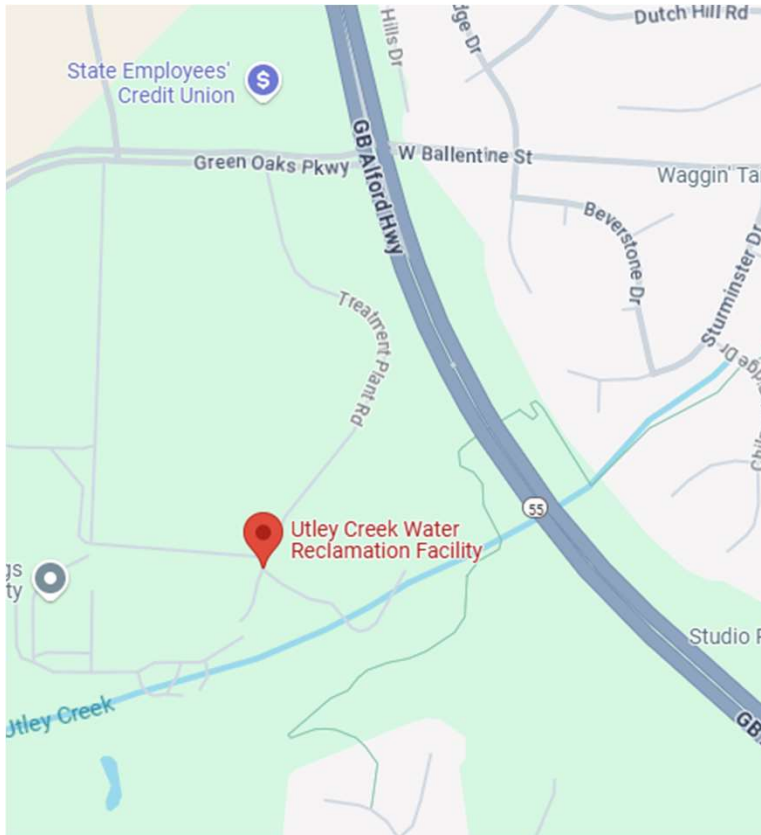

Contract Durations

Critical Path for overall UCWRF Expansion Project

Contract	Number of Days	Owner's damages	Engineering Charges	Total Liquidated Damages
Clearing/Grub/Grading/ E&SC Basins	120	\$3,500/day	\$1,500/day	\$5,000/day
Duct Bank and Temporary Rds	270	\$3,500/day	\$1,500/day	\$5,000/day
From NTP to Substantial Completion	510	\$3,500/day	\$1,500/day	\$5,000/day
From Substantial Completion to Final Completion	30	\$1,500/day	\$1,000/day	\$2,500/day

Project Components

- Construction of a new 7,900-sf Lab and Operators Building and parking areas.
- Site access roads
- Stormwater detention ponds
- Security fence
- Erosion and sedimentation control
- Underground utilities

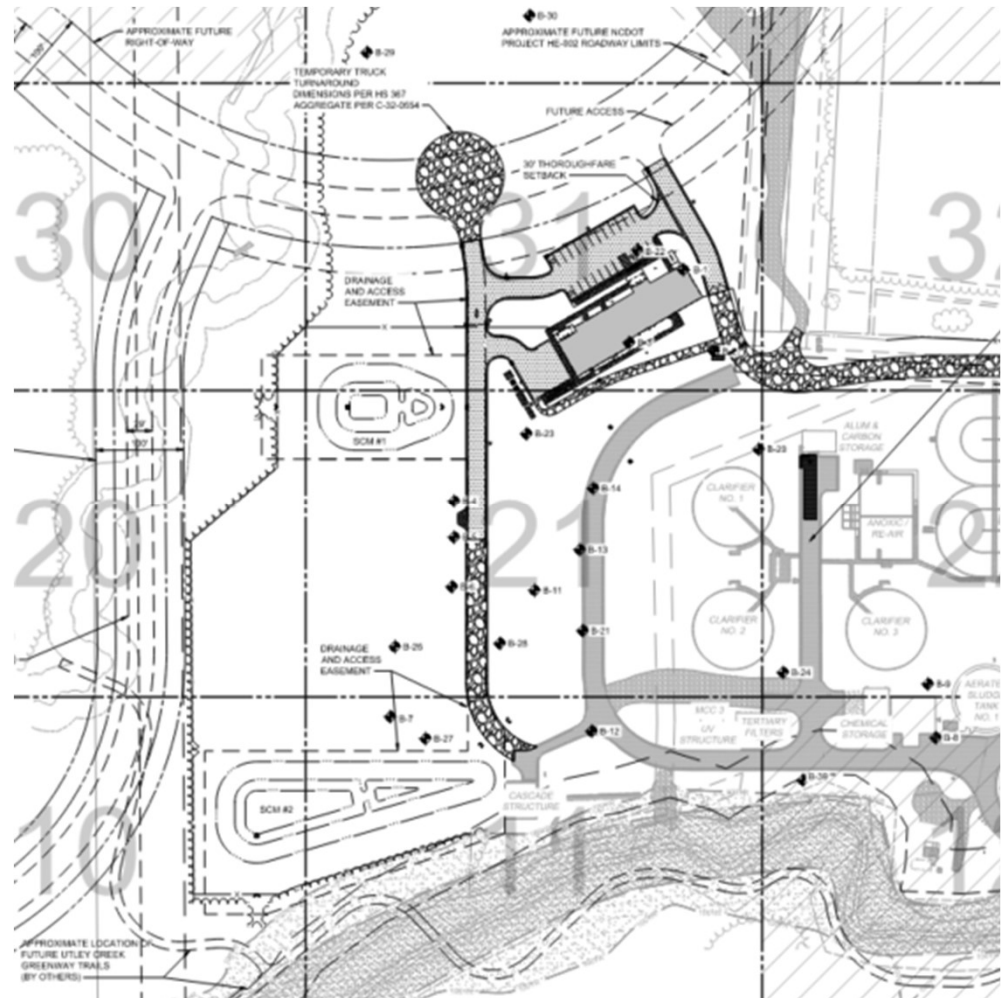

Project Components provided by the Others

Owner

- Temporary generator to provide backup power. (Refer to Contract Drawing E003)
- Existing Lab equipment (Refer to Contract Drawing A819)
- SCADA and network conversion
- Camera and Site security

Duke Energy

- Site Lighting
- EV charging stations
- Site power
 - *Contractor is responsible for installation of ductbanks

Erosion and Sedimentation Controls

- Erosion Control Phase 1
 - Perimeter measures
 - Sediment basins
 - Diversion channels
- Erosion Control Phase 2
 - Storm drain network
 - Permanent channels
 - Slope matting
- Two sediment basins will be converted to permanent wet ponds, third basin is temporary

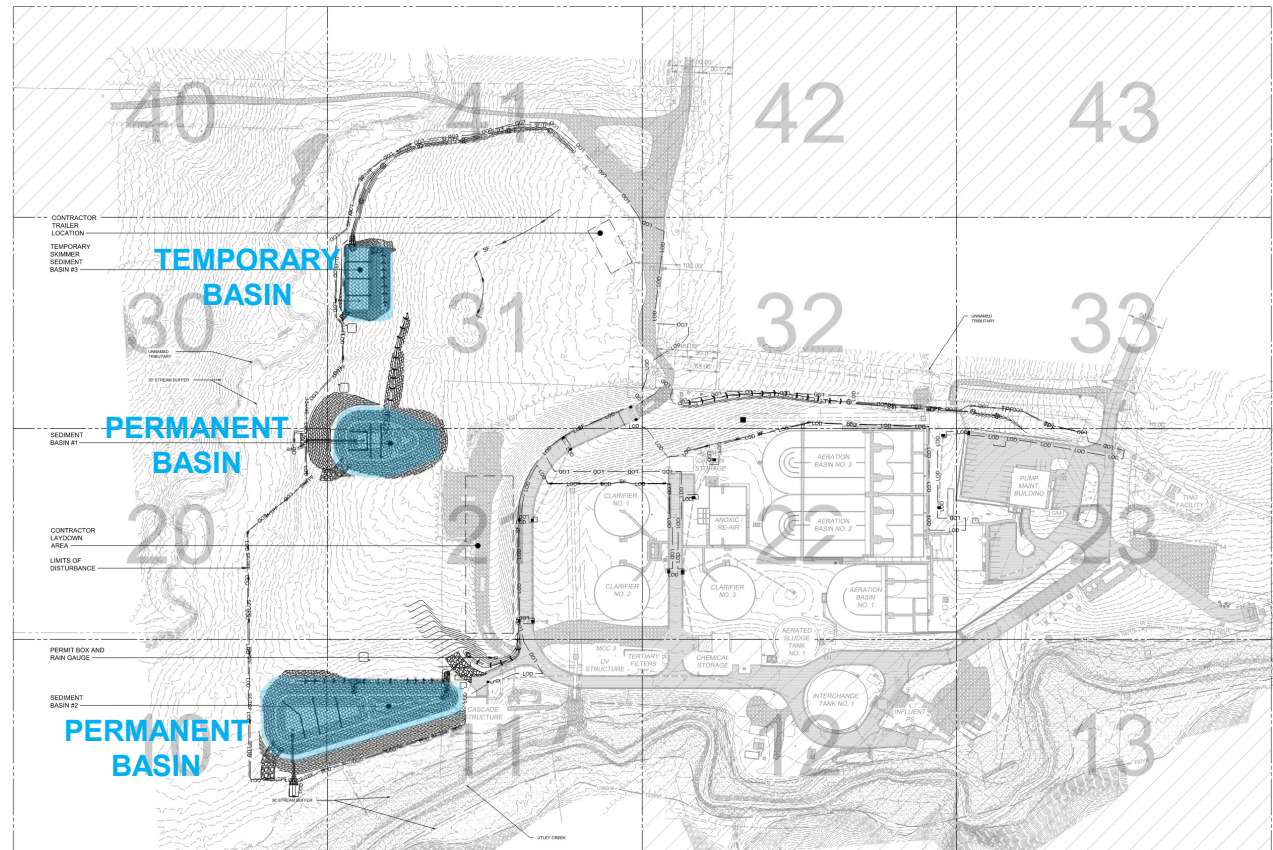

C200 Phase 1 Erosion Control Plan

Clearing and Demolition

- 12 Acre Limit of Disturbance
- Site clearing and grubbing to be completed following installation of Phase 1 Erosion Controls

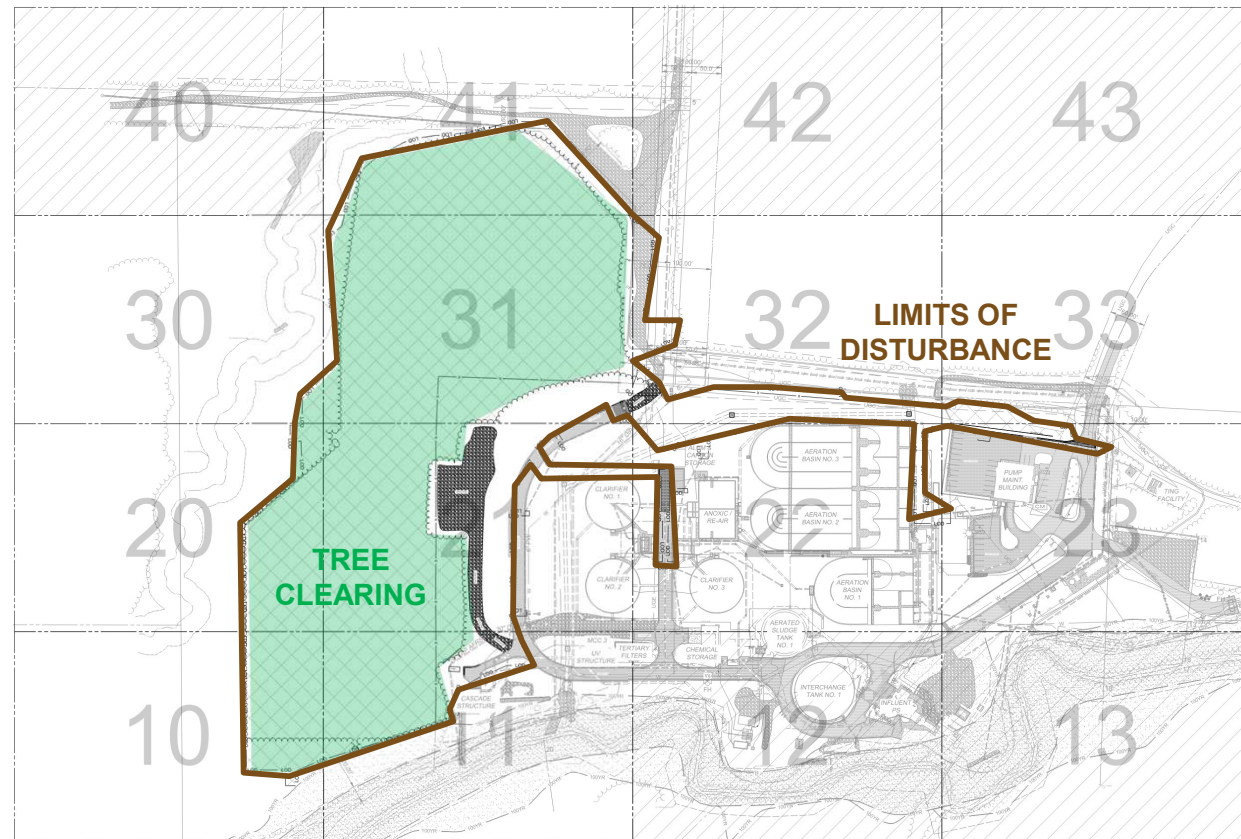

C300 Demolition Plan

Site Restrictions

- Contractor Trailers/Laydown
- Parking
- Traffic limits
- Road use limits
- Refer to 01 55 00 for site access and parking restrictions

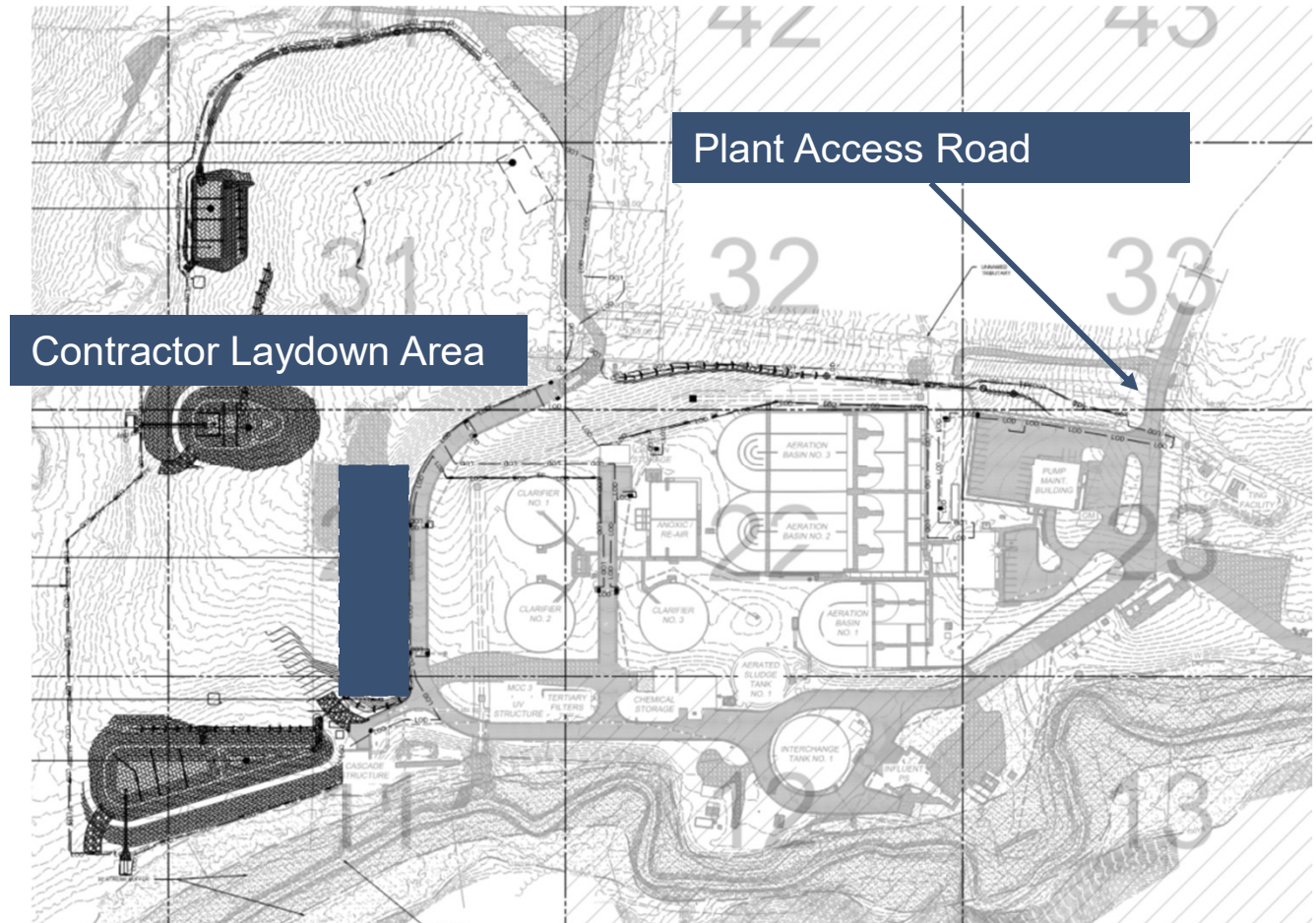

Roads

- Project includes new asphalt paved and gravel access roads
- New gravel access road not intended for construction access/equipment
- Roads between clarifiers and around interchange tank are not for Contractor's use.
- The site is an actively operating facility that is managed 24/7
- Owner access must be provided at all times
- See Section 01 55 00

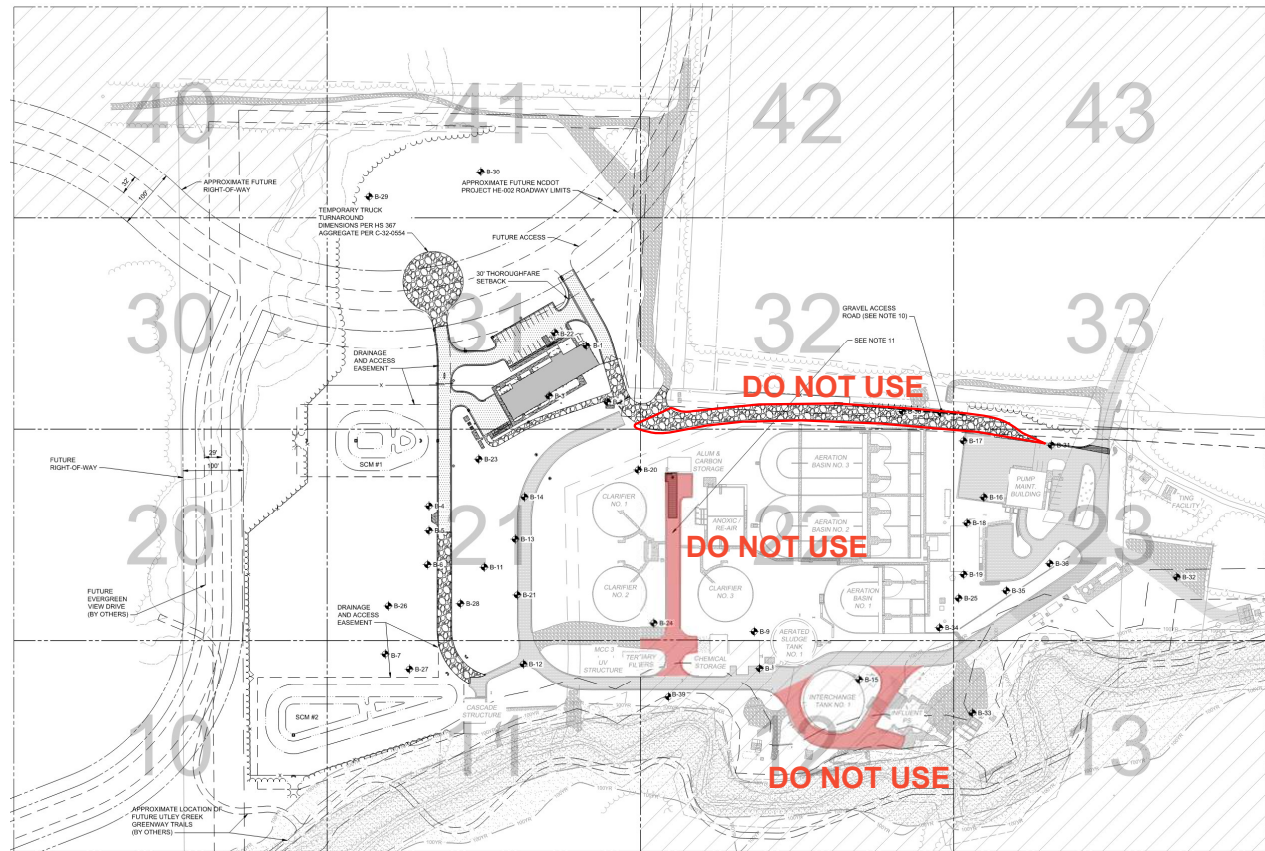

C300 Site Layout Plan

Underground Utilities

- The Contractor shall contact NC811.com or 1-800-632-4949 to request underground utility location mark-out at least three (3) working days, not including the day the request is called in, but no more than ten (10) working days prior to the beginning of excavation.
- Notify utility owners and other concerned entities at least 48 hours prior to cutting or closing streets or other traffic areas or excavating near Underground Facilities or exposed utilities.

Lab & Operators Building

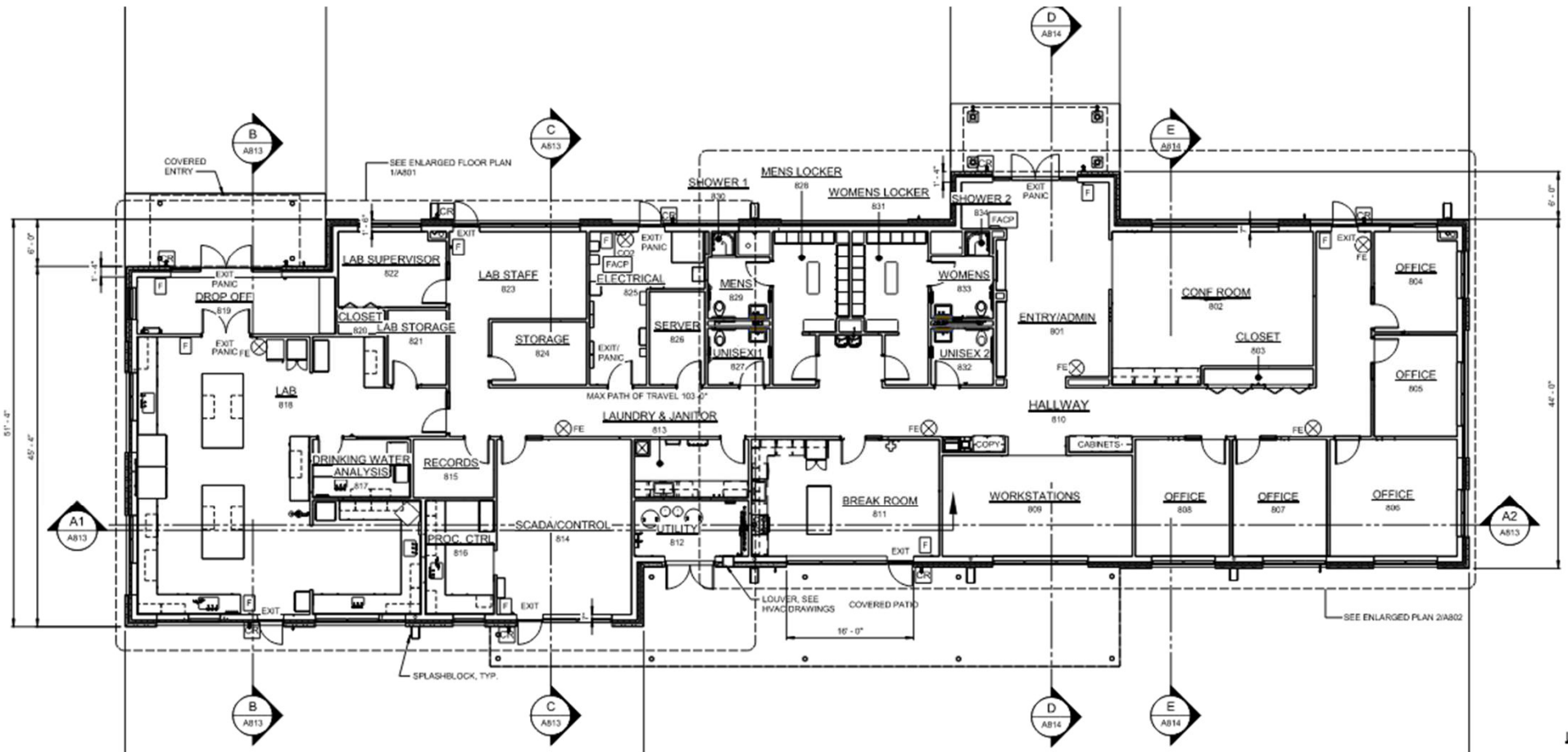

Lab & Operators Building – Delegated Design

- Pre-Engineered, Prefabricated Cold Formed Steel Roof Trusses (05 44 00) and Load Bearing Cold Formed Metal Framed Building (05 40 05)
 - Contractor shall retain a subcontractor who is responsible for the designs, calculations.
 - Drawings shall be signed and sealed by professional engineer.
 - Review discipline drawings for coordination



Lab & Operators Building – Delegated Design con't

- Building Control System (23 09 02)
 - ATC Contractor shall furnish and install all HVAC Automatic Temperature Controls components and accessories
- Fire Alarm System (28 46 20)
 - Contractor shall hire a licensed professional engineer in the State to review the requirements and design the system.
 - Contractor shall submit the Drawings to the Fire Marshal of Town of Holly Springs and coordinate the approval process.



Furnishings

- Allowance: \$175k
- Refer to A828 for furnishing details

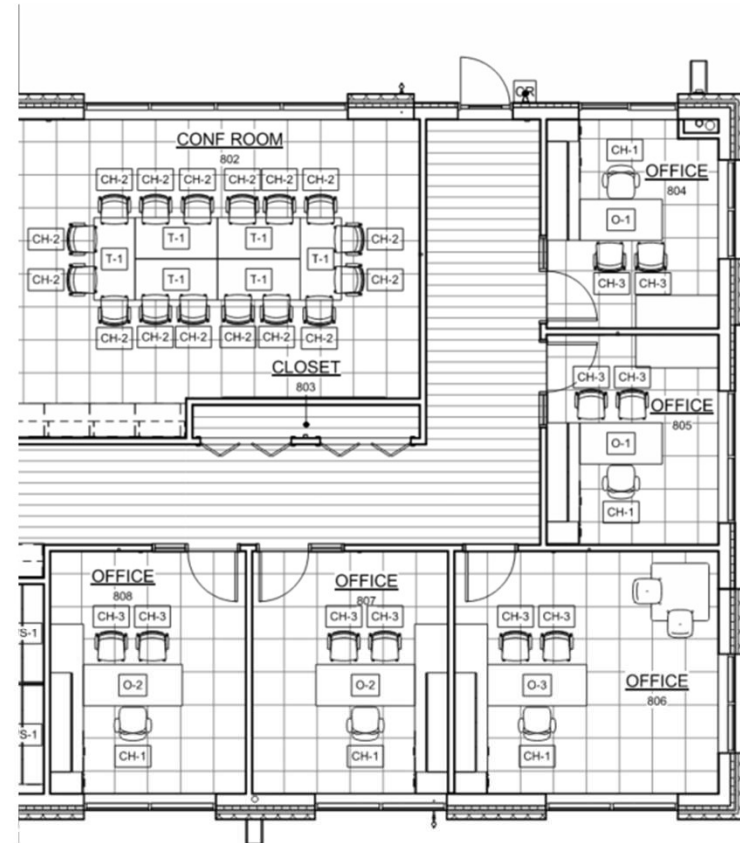

O-1



O-2



O-3

Laboratory

- New Appliances as noted on Contract Drawings A819.
- Allowance:
 - \$45k
- Selected equipment from Administrative Building Laboratory as noted on A819.

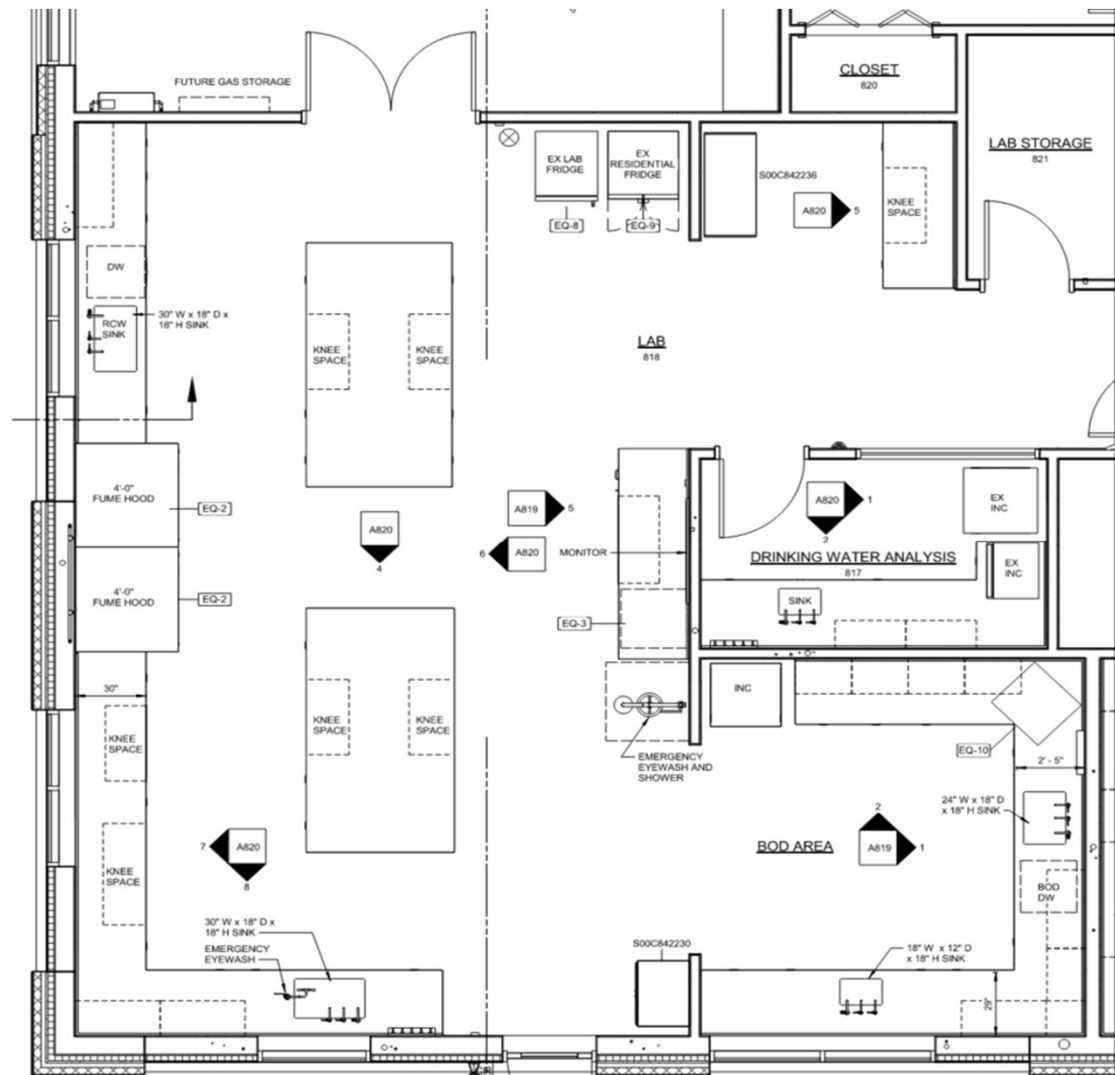

Coordination with Owner's Operations (Section 01 14 00)

- Shutdowns shall be scheduled at least 30 days in advance.
- Provide written shutdown notification at least 72 hours in advance of each shutdown.
- At all times during construction, Owner's personnel shall have access to equipment and areas that remain in operation.
- Start-up
 - HVAC System

Bidding Requirements

Bidding Requirements

*Bid Proposals shall be received until 2:00 p.m., Tuesday, June 10, 2025
at the Town of Holly Springs Finance Department
128 S. Main St. Holly Springs NC 27540*



Bidding Requirements

- Bid Form / Proposal is included in Section 00300
- Bid Form shall contain acknowledgement of receipt of Addenda.
- Award of Contract
 - Town of Holly Springs reserves the right to reject any or all bids and to award the contract in the best interest of the Project
 - Town of Holly Springs reserves the right to award Project based on total bid, the total bid less the deductive alternates, the total bid plus the additive alternates, or any combination
- List of Subcontractors AND List of Major Equipment Manufacturers
 - **List will be required to be submitted with the bid**
- List of Bids will be read aloud at opening, assuming sufficient bids are received
- Project is not funded by State Revolving Funds or other State/Federal Grants or Loans
 - No Davis Bacon, American Iron and Steel, or BABA requirements

Bidding Requirements

- Section 00250 Instructions to Bidders
- Bid security (Bid bond or certified check) not less than 5% of the total amount of the base bid
- Documents to be submitted with Bid (refer to contract documents)
 - *Bid Form (00300)*
 - *MBE/WBE Construction Forms:*
 - Town of Holly Springs, MWBE Forms (00905)
 - *Non-Collusion Affidavit of Bidder*
 - *List of Equipment / Material Manufacturers*
 - *E-Verify Affidavit Form*
 - *Certificate of Insurance*

ToHS M/WBE Requirements

- TOHS current goal for minority participation is 10%
- MBE firms should hold at least one of the following certification to be eligible:
 - North Carolina Administration Department Historically Underutilized Business (HUB) certification.
 - North Carolina Department of Transportation Minority/Disadvantage/Woman- owned Business certification.
 - Small Business. Administration 8(a) certification.
 - Other governmental agencies on a case-by-case basis.

Bidding Requirements – Page 1, Itemized Bid Proposal

Lump Sum Bid Items

1. All work for the UCWRF Lab and Operators Building (Excluding Bid Items 2 - 7)
2. Mobilization
3. Clearing and Grubbing
4. Erosion and Sedimentation Control
5. Excavation (Unclassified)
6. Lab Equipment Allowance
7. Furniture Allowance

Bidding Requirements – Page 1, Itemized Bid Proposal

Deductive Alternates

- D-1 CMU Block Veneer
- D-2 Covered Patio Canopy
- D-3 Parapet
- D-4 Landscaping

Additive Alternates

- A-1 ICP
- A-2 Aluminum Coping and Canopy Color
- A-3 Aluminum Sunshade Color

Deduct. – 1

Exterior Veneer

- Brick veneer → Larger CMU Block (04 20 00)



EXAMPLE

Deduct. – 2

Reduce rear canopy length by 18'-10"

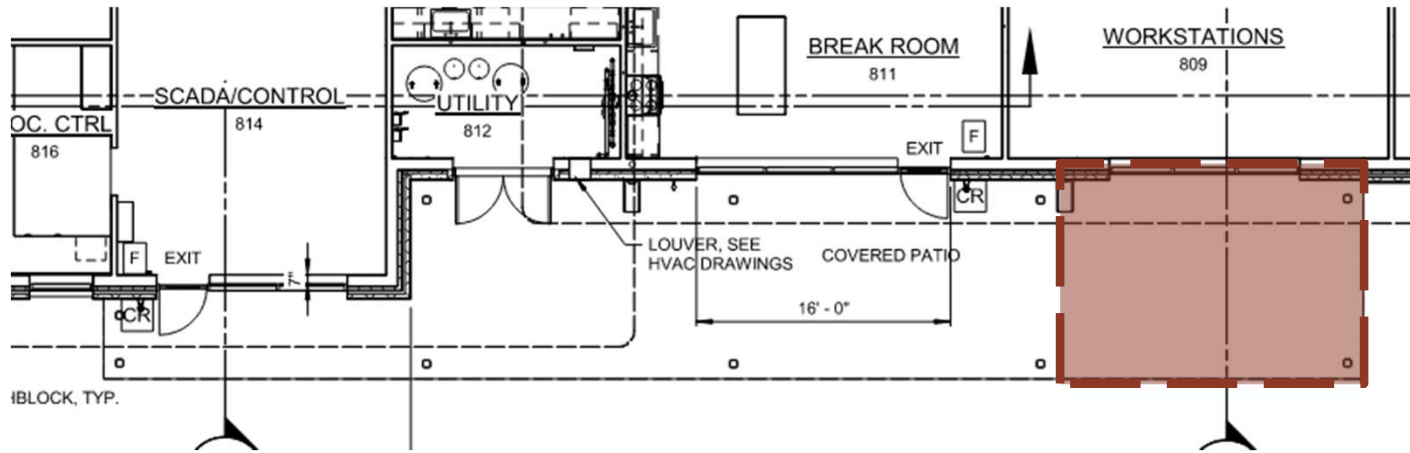

Exterior View – Rear

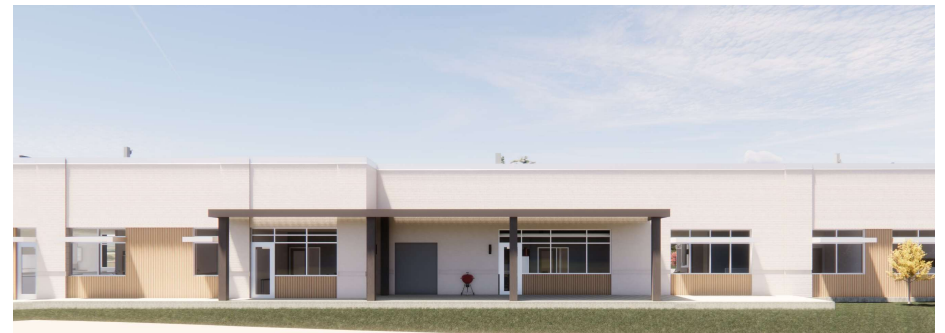

Exterior View – Rear (Revised)

Deduct. – 3

Reduce building parapet height to 1'-4"

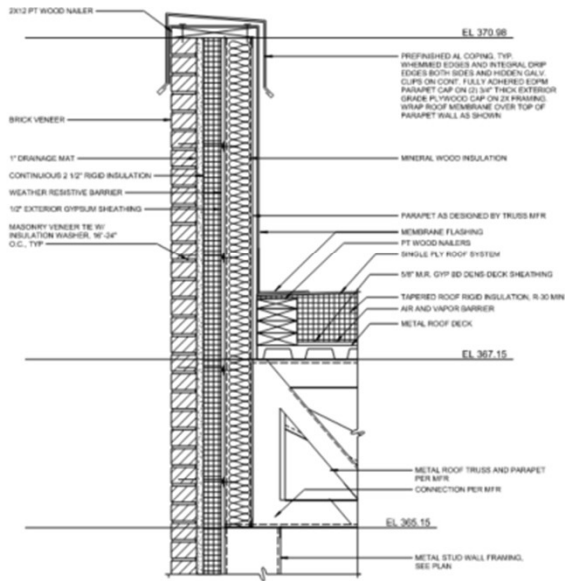

PARAPET 1
 DETAIL 1
 1 1/2" x 1'-0"
 A815

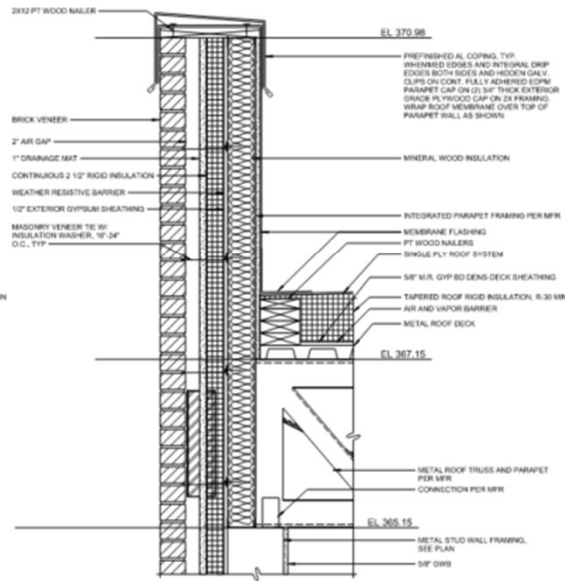

PARAPET 2
 DETAIL 2
 1 1/2" x 1'-0"
 A815

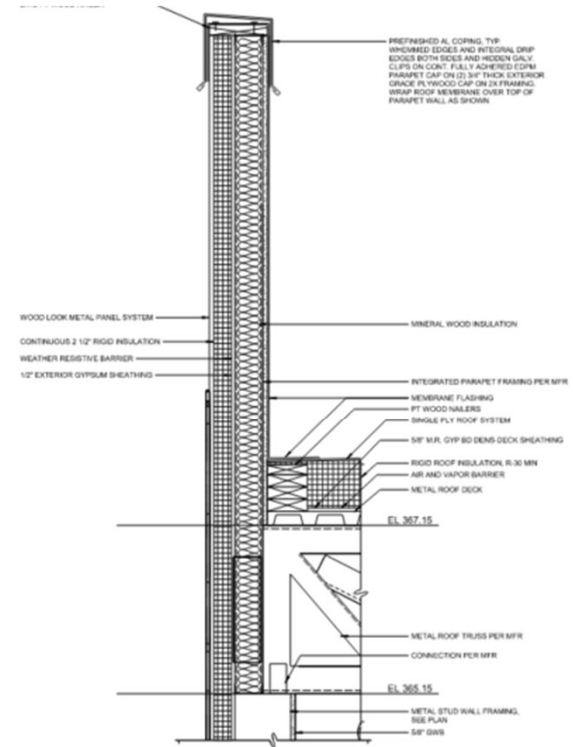

METAL PANEL PARAPET
 DETAIL 3
 1 1/2" x 1'-0"
 A817

Deduct. – 4

- Active Recreation Trail around SCM#1
- One Bench
- Bicycle Rack
- Portion of the Landscaping

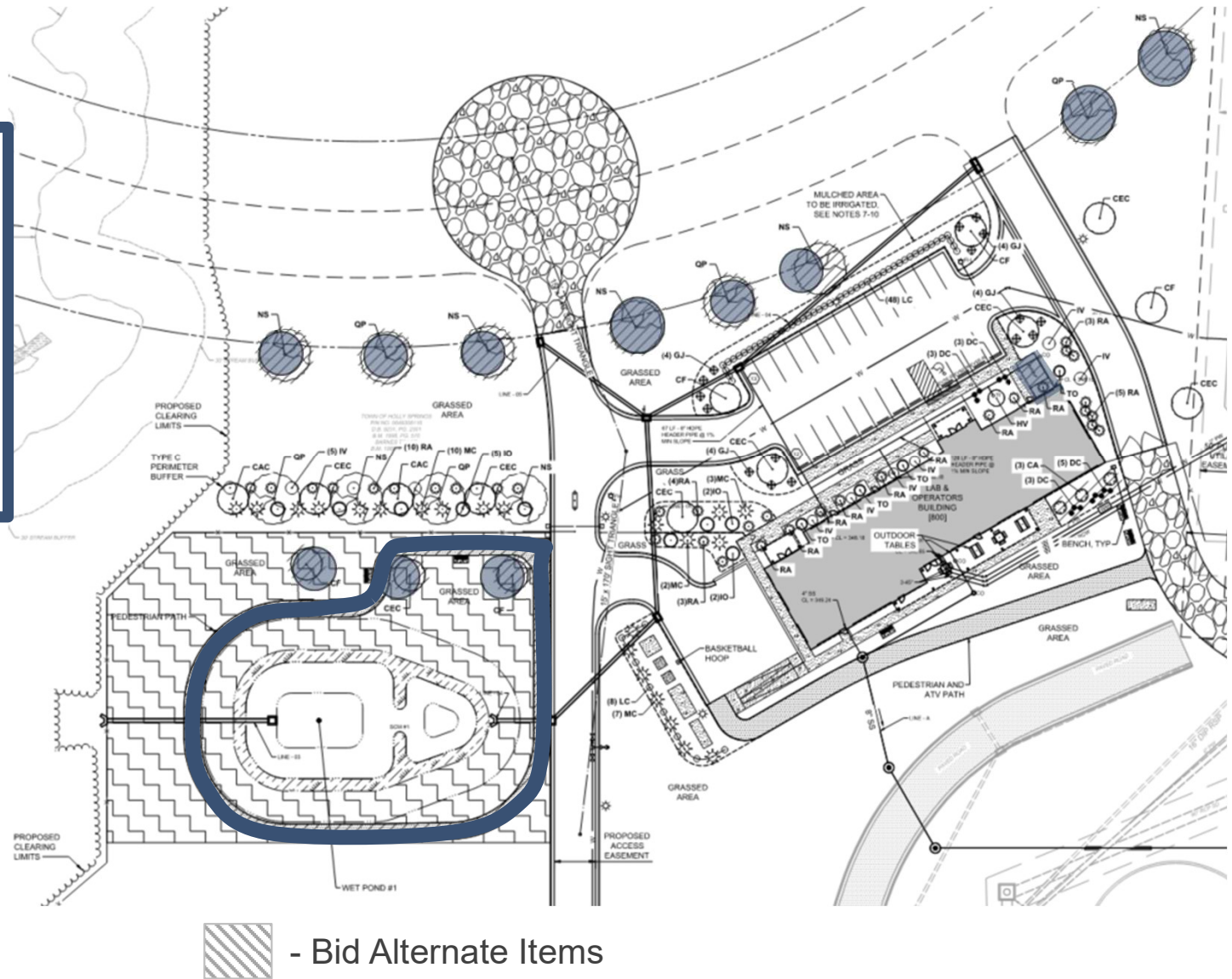

Questions

- All questions about the meaning or intent of the Bid Document or Contract Documents shall be submitted to Engineer in writing. Email questions to: tohs_ucwrf_labopsbldg@hazenandsawyer.com
- Verbal responses do not change contract documents

Site Visit

- Town and Hazen will identify several dates via addendum.

Questions?

ATTENDEE SIGN IN
Pre-Bid Meeting

UCWRF – Lab and Operators Building
Town of Holly Springs
May 21, 2025 – 1:30 PM
TH Holleman Room
Town Hall, 128 S Main St, Holly Springs, NC 27540

NAME	COMPANY	PHONE	EMAIL
Terry Foster	TOMS	919-524-9871	terry.foster@hollysprings.nc
David Wankmoller	Hazen	908-642 8325	dwankmoller@hazenandsawyer.com
Rachel Ingham	TOMS	919-501-0741	rachel.ingham@hollyspringsnc.gov
Cassidy Plumridge	Hazen	727-501-4537	cplumridge@hazenandsawyer.com
Michelle Mayes	Hazen	832 794 9865	mmayes@hazenandsawyer.com
Pedro Cortez	SBM		estimating@sanchezbrothersma sonry.com
Jack Pendergraff	Samet	336 380 9054	jpendergaff@sametcorp.com
Zachary P. Cotten	Intrepid Build	919-909-5961	zcotten@intrepid-build.com
Math Marshall	Ivey mechanical	910 578 1995	matthew.marshall@Iveymechanical.com
DEAN DENNING	MONTGITH	919.750.4192	ddenning@montgithcuicw
Jason Moos	Morgan Corp	252-341-7903	jmoos@morgan-corp.com
Lynne Bach	Muter Construction	919 404 8330	BuildingBids@MuterConstruction.com

NAME	COMPANY	PHONE	EMAIL
JAY WILLKINS	CMS Contalos	919 201-4577	jwillkins@cms-contalos
Ashley SNEADE	STERWIN	336-558-3335	ASHLEY.B.SNEADE@STERWIN.COM

Virtual

LAST READ

Ammeen Nader (External) 1:34 PM

AN Ammeen Nader
Buildcorp, Inc.
Email: ammeen@buildcorpinc.com
Phone: (919) 645 - 8030

1:34 PM Rachel Ingham started recording to the cloud

Afshin Roshdi (Unverified) 1:34 PM

AR Afshin Roshdi, Buildcorp, Inc., 919.868.7888, afshin@buildcorpinc.com

John Graham (External) 1:34 PM

JG John Graham, Focus Design Builders, 919-805-5732, jgraham@focusdesignbuilders.com

Marty Rentschler (External) 1:35 PM

MR Marty Rentschler,
Senior Project Manager
Msquare Construction, Inc.
Email: mrentschler@msquareus.com
Phone: (910) 929-7668

SECTION 26 36 23
AUTOMATIC TRANSFER SWITCHES

PART 1 – GENERAL

1.01 THE REQUIREMENT

- A. The Contractor shall furnish, install, connect, test, and place in satisfactory operation automatic transfer switches (ATS) as specified herein and indicated in Drawings.
- B. Reference the following Specification Sections:
 - 1. Section 26 05 00 – Basic Electrical Requirements
 - 2. Section 26 05 53 – Identification for Electrical Systems
 - 3. Section 26 09 16 – Electric Controls and Relays
 - 4. Section 26 43 13 – Surge Protection Devices
- C. Where indicated on the Drawings, the ATS shall serve as the service entrance equipment.
- D. Where replacement of existing ATS, or addition of new ATS to existing facilities, is indicated on the Drawings, the Contractor shall coordinate the sequencing of the Work and any require shutdowns as indicated on the Drawings and specified in Section 01 14 00 – Coordination with Owner’s Operations.
- E. The ATS shall contain circuit breakers or contactors (type for each ATS shall be as indicated on the Drawings), control devices, and all accessories as specified herein, indicated on the Drawings, and as required to result in a complete and operable power distribution equipment assembly.
- F. The ATS shall be assembled using NEMA rated components. Components designed and built to InterNational Electrotechnical Commission (IEC) standards are not recognized. Equipment designed, manufactured, and labeled in compliance with IEC standards is not acceptable.

1.02 CODES AND STANDARDS

- A. All equipment shall be Listed by and shall bear the Label of Underwriter's Laboratories, Incorporated (UL).

- B. The equipment shall be designed, manufactured, and/or Listed to the following standards as applicable:
1. American National Standards Institute (ANSI)/Institute of Electrical & Electronic Engineers (IEEE):
 - a. 446 – ANSI/IEEE Recommended Practice for Emergency and Standby Power Systems for Commercial and Industrial Applications
 2. National Fire Protection Association (NFPA):
 - a. NFPA 70 – National Electrical Code (NEC) – Articles 700, 701, 702.
 3. National Electrical Manufacturers Association (NEMA):
 - a. NEMA ICS 10 – Industrial Control and Systems Part 1: Electromechanical AC Transfer Switch Equipment.
 4. Underwriters Laboratories (UL):
 - a. UL 1008 – Transfer Switch Equipment.

1.03 SUBMITTALS

- A. In accordance with the procedures and requirements set forth in the General Conditions and Section 01 33 00 – Submittal Procedures, the Contractor shall obtain from the equipment manufacturer and submit the following:
 - 1. Shop Drawings
 - 2. Operation and Maintenance Manuals
 - 3. Spare Parts Lists
 - 4. Proposed Testing Methods and Reports of Certified Shop Tests.
 - 5. Reports of Certified Shop and Field Tests. Reports of certified shop tests shall be submitted which indicates a closing and withstand ampere rating as required based on short circuit study requirements. Rating shall be symmetrical, three-cycles at 480 VAC.
 - 6. Manufacturer's Representatives Installation Certification
- B. Each submittal shall be identified by the applicable Specification Section.

1.04 SHOP DRAWINGS

- A. Each submittal shall be complete in all respects, incorporating all information and data listed herein and all additional information required for evaluation of the proposed equipment's compliance with the Contract Documents.
- B. Partial, incomplete, or illegible submittals will be returned to the Contractor without review for resubmittal.
- C. Shop drawings for each ATS shall include but not be limited to:
 - 1. A Compliance, Deviations, and Exceptions (CD&E) letter. If the shop drawings are submitted without this CD&E letter, the submittal will be rejected. The letter shall include all comments, deviations, and exceptions taken to the Drawings and Specifications by the Contractor AND Equipment Manufacturer/Supplier. This letter shall include a copy of this Specification Section. In the left margin beside each and every paragraph/item, a letter "C", "D", or "E" shall be typed or written in. The letter "C" shall be for full compliance with the requirement. The letter "D" shall be for a deviation from the requirement. The letter "E" shall be for taking exception to a requirement. Any requirements with the letter "D" or "E" beside them shall be provided with a full typewritten explanation of the deviation/exception. Handwritten explanation of the deviations/exceptions is not acceptable. The CD&E letter shall

also address deviations and exceptions taken to each Drawing related to this Specification Section.

2. Bill of material list for the ATS.
 3. Equipment specifications and product data sheets identifying all electrical ratings. This information shall include all equipment and devices comprising the ATS.
 4. Complete assembly, layout, anchoring, and installation drawings with clearly marked dimensions. These drawings shall include, but not be limited to:
 - a. Plan, front, and side view drawings, including overall dimensions of the ATS assembly.
 - b. Required clearances around the enclosure (e.g., ventilation clearances).
 - c. Identify conduit entry areas and/or stub-up area locations on the drawings.
 - d. Physical arrangement of door mounted devices located on the ATS enclosure.
 - e. Physical arrangement of all interior components, including DIN-rail-mounted devices. General "catalog data sheet" layout drawings which are not specific to the systems specified herein are not acceptable.
 5. Approximate total shipping weight of the complete ATS assembly.
 6. Complete, custom internal wiring diagram of each ATS assembly. Each wiring diagram shall include wire identification and terminal numbers.
 7. Example equipment nameplate data sheet.
 8. Nameplate schedule.
 9. Manufacturer's installation instructions.
 10. Spare parts list. Spare parts shall be as specified herein.
 11. Manufacturer's written warranty statement.
- D. The shop drawing information shall be complete and organized in such a way that the Engineer can determine if the requirements of these specifications are being met. Copies of technical bulletins, technical data sheets from "soft-cover" catalogs, and similar information which is "highlighted" or somehow identifies the specific equipment items the Contractor intends to provide are acceptable and shall be submitted.

1.05 OPERATION AND MAINTENANCE MANUALS

- A. The Contractor shall submit operation and maintenance manuals in accordance with the procedures and requirements set forth in the General Conditions and Division 01. The manuals shall include, but not be limited to:
 - 1. Instruction books and/or leaflets.
 - 2. Spare parts list.
 - 3. Final as-built construction drawings (updated from those included in the Shop Drawings) incorporating all changes made in the manufacturing and installation process.
 - 4. All other drawings, product information, and other materials originally included in the Shop Drawings, updated as necessary to reflect as-built conditions.
 - 5. Include the "as-commissioned" parameters of each ATS in both print and digital formats.
- B. Prior to completion and final acceptance of the project, the Contractor shall furnish "as-built" wiring diagrams for each ATS. These final diagrams shall be included in the O&M manuals and an additional copy that is plastic laminated shall be securely placed inside each ATS.

1.06 SPARE PARTS

- A. The ATS shall be furnished with all spare parts as recommended by the equipment manufacturer.
- B. Reference Section 26 05 00 – Basic Electrical Requirements for spare parts delivery and handling requirements.

1.07 IDENTIFICATION

- A. Each ATS shall be identified with the identification name and/or number indicated on the Drawings (e.g., ATS-PP-FEB). A nameplate shall be securely affixed in a conspicuous place on the ATS.
- B. Nameplates shall be as specified in Section 26 05 53 – Identification for Electrical Systems.

1.08 WARRANTY

- A. Contractor and Manufacturer shall warrant that the material and workmanship of all components and the operation of the equipment is in accordance with the latest design practices and meets the requirements of this Specification.

- B. Warranty shall include, but not be limited to the following:
 - 1. Replace equipment/components found to be faulty, make changes in equipment arrangement, and/or make adjustments necessary to meet the equipment or functional requirements of this Specification.
 - 2. System rewiring and component substitution/rebuild.
 - 3. All accessories and appurtenances provided by the equipment manufacturer.
- C. Warranty for each ATS shall be in effect for a period of five (5) years following final acceptance of the ATS.

PART 2 – PRODUCTS

2.01 MANUFACTURERS

- A. The equipment covered by this Specification is intended to be standard equipment of proven performance as manufactured by reputable concerns. Equipment shall be designed, constructed, and installed in accordance with the best practices of the trade, and shall operate satisfactorily when installed as shown on the Drawings.
- B. It is the intent of these Specifications that the ATS be manufactured and assembled by a single manufacturer who shall be responsible for matching all components and providing equipment which functions together as a system. The manufacturer shall have five (5) years minimum of experience in the manufacture of similar units and shall have a general distribution to the electrical trade. Subcontracting of wiring and/or third-party assembly is not acceptable.
- C. The ATS manufacturer shall certify that the switches are UL 1008 Listed and Labeled, with three-cycle withstand and close-in values as indicated on the Drawings or specified herein.
- D. The ATS shall be Type ATC (Open Delayed Transition) with ATC-900 controller as manufactured by Eaton, ASCO Series 7000 with Group 5 controller, or engineer approved equal.

2.02 AUTOMATIC TRANSFER SWITCH

- A. General
 - 1. The ATS shall have ampere ratings and number of wires/poles as indicated on the Drawings, and shall be suitable for 480 VAC, three-phase, 60 Hertz operation.

2. Each complete ATS assembly shall bear a UL 1008 Label. Where indicated on the Drawings, the ATS shall be suitable for use as service entrance equipment and bear a service entrance label. Service entrance ATS shall be furnished with a keyed selector switch that disconnects the load from all sources.
3. Each ATS shall be suitable and configured for use when supplied by respective type(s) of incoming sources as indicated on the Drawings (e.g., utility/utility, utility/generator, feeder/feeder).
 - a. Where specified in the "Controls" section herein for the specific ATS/controller type, ATS supplied by utility/utility or feeder/feeder sources shall be capable of preferred source selection. References to "Source 1" herein shall apply to the selected preferred source, and "Source 2" to the non-preferred source.
 - b. For ATS supplied by utility/generator sources, references to "Source 1" herein shall apply to the utility source, and "Source 2" to the generator source.
4. Where indicated on the Drawings as four-wire (4W), three-pole (3P) (i.e., an unswitched neutral is required), the ATS shall be furnished with a fully rated solid neutral bus.
5. Where indicated on the Drawings as four-wire (4W), four-pole (4P) (i.e., a switched neutral is required), a true four-pole ATS shall be supplied with all four electrically and mechanically identical poles mounted on a common shaft. The continuous current rating and the closing and withstand rating of the fourth pole shall be identical to the rating of the main poles (i.e., fully rated).
6. The ATS shall be capable of switching all classes of load and rated for continuous duty when installed in a non-ventilated enclosure.
7. The three-cycle closing and withstand current rating of the ATS shall be as follows:
 - a. 30,000 amperes rms (minimum) for switches rated up to 400A.
 - b. 50,000 amperes rms (minimum) for switches rated up to 1200A.
8. The ATS shall be complete with all accessories and suitable for use on emergency systems (per UL 1008).
9. The ATS shall be equipped with copper/aluminum solderless mechanical type lugs of the proper quantity and size to accommodate the termination of all field wiring indicated on the Drawings.

B. Enclosures

1. Where located in indoor dry areas: the ATS shall be housed in a NEMA 1 (gasketed) enclosure fabricated from 12-gauge steel. Enclosure interior and exterior finish paint color shall be ANSI 49 or 61 grey, using the manufacturer's standard painting process.
2. Where located outdoors or in indoor wet locations: the ATS shall be housed in a NEMA 3R enclosure fabricated from Type 304 stainless steel. Where located outdoors, the enclosure shall include a lockable stainless steel controller cover. Enclosures shall be furnished complete with fused, thermostatically controlled space heaters. The Contractor shall wire heaters to provide temporary heating during storage.
3. Enclosures shall be suitable for wall-mounting or freestanding floor-mounting as indicated on the Drawings or required for the size/application.
4. Enclosures shall exceed the UL 1008 minimum wire bending space requirements.
5. Hinged outer enclosure door shall include a padlockable handle.
6. Enclosures shall have top, bottom, and side conduit entry.
7. Enclosures shall be equipped with an internal, welded steel, door-mounted print pocket.
8. A minimum of one (1) 4" infrared inspection port in the front door of each ATS. IR ports shall be located to allow IR observation of the cable terminations within the enclosure. IR ports shall meet requirements of IEEE C37.20.2 and shall maintain the NEMA rating of ATS enclosure even when in use.

C. Design Requirements

1. The ATS shall be a three-position switch configured for "break-before-make" open-delayed transition. A center "OFF" position shall be provided as a neutral position during switching.
2. ATS shall contain an electrically operated and mechanically held double-throw, power switching contactor mechanism utilizing a spring stored-energy mechanism for quick-make, quick-break operation. The mechanism shall permit both electrical and manual operation. The switch shall be mechanically interlocked to ensure the preferred and alternate sources cannot be paralleled.
3. An adjustable time delay between the opening of one source and closing onto the other source (open-delayed transition) shall allow for voltage decay before transfer, allowing the motor and transformer loads to be re-energized after transfer with normal in-rush current. ATS using in-phase monitors are not acceptable.

4. The ATS main contacts shall be silver-tungsten alloy, mechanically locked in position in both the Source 1 and Source 2 position. Provide separate arcing contacts, with magnetic blowouts on each pole.
5. All ATS bussing shall be tin-plated copper for aggressive environments. All bolted bus connections shall have Belleville compression type washers.
6. Equip each ATS with a permanently attached, safe, manual operator designed to prevent injury to personnel in the event the electrical operator should become energized during manual transfer. The manual operator shall provide the same source-to-source transfer speed as the electrical operator to prevent a flashover from slowly switching the main breakers/contacts.
7. The ATS shall be capable of normal operation after seismic loading. Reference Section 01 73 23 – Anchorage and Bracing of Non-Structural Components.
8. The ATS shall be furnished with a solid-state meter to transmit power and energy data via BACnet to owner's SCADA system. Provide Eaton PXM1100 or equivalent by ASCo.
9. The ATS shall be furnished with additional dry contact outputs for load shedding upon the transition to standby power. The loads that will be shed on standby power are defined on the electrical drawings.

D. Controls

1. The ATS shall be equipped with a microprocessor-based control system to provide all the operational functions of the The controller shall include the sensing and timing functions necessary to execute the sequence of operation as specified herein. The controller shall have a real time clock with battery back-up. The controller shall be programmed by the manufacturer (either at the factory or during startup).
2. The ATS shall include fused control power transformers (CPTs), power supplies, integral best-source selection, and all accessories and appurtenances required to derive control power from either available/connected source (Source 1 or Source 2).
3. The controller shall be equipped with self-diagnostics which perform periodic checks of the memory, I/O, and communication circuits with a watchdog power fail circuit.
4. The controller shall have password protection to limit access to authorized personnel.

5. The controller shall include an RS-485 serial communications port. The controller shall use industry standard open architecture communication protocol(s) (e.g., Modbus RTU) for high speed serial communications and shall be capable of transmitting all available operational data and alarms to the Owner's supervisory control (SCADA) system.
6. The controller shall include an accessory card/module for EtherNet/IP communication. The card/module may be an adapter/converter which utilizes the controller's integral RS-485 serial communications port if necessary. The Ethernet port shall be capable of transmitting all available operational data and alarms to the Owner's supervisory control (SCADA) system.
7. The ATS/controller shall include the following specific features, functionality, and/or accessories (in addition to all other requirements specified elsewhere herein):
 - a. The controller shall include a two-line sixteen-character (per line) LCD display and a keypad which allows access to the system.
 - b. The LCD display shall display both Source 1 and Source 2 availability/status.
 - c. The controller shall include metering of Source 1 and Source 2 voltage (V) and frequency (Hz). Metering values shall be viewable on the LCD display via keypad navigation as follows:
 - 1) Voltage (selectable line-to-line voltage for each phase) with +/-1% accuracy for both Source 1 and Source 2.
 - 2) Frequency with +/-0.3Hz accuracy for both Source 1 and Source 2.
8. For Molded Case Circuit Breaker (MCCB) Type ATS specified herein with Eaton ATC-900 (or approved equal) controllers: The ATS/controller shall include the following specific features, functionality, and/or accessories (in addition to all other requirements specified elsewhere herein):
 - a. The controller shall include a 4.3-inch UV-resistant color LCD display and a keypad which allows access to the system. The controller shall be capable of displaying transfer switch status, parameters, and diagnostic and metering information.
 - b. The controller LCD display shall annunciate both Source 1 and Source 2 availability/status.
 - c. The ATS/controller shall include preferred source selection capability (via keypad selection).

- d. The controller shall include an accessory module, current transformers (CT), and required appurtenances for full integral power/load metering including current (amps), real power (kW), reactive power (kVAR), apparent power (kVA), and power factor (PF) in addition to standard metering of voltage (V) and frequency (Hz) for Source 1, Source 2, and Load. Metering values shall be viewable on the LCD display as follows:
 - 1) Simultaneous display of all three line-to-line voltages with +/-1% accuracy for Source 1, Source 2, and Load.
 - 2) Simultaneous display of all three line (phase) currents with +/-1% accuracy.
 - 3) Simultaneous display of frequency with +/-0.2Hz accuracy for both Source 1 and Source 2.
 - 4) Simultaneous display of Load power metering values (kW, kVAR, and kVA) with +/-1% accuracy and power factor (PF).
9. Controllers shall include, as a minimum, a front panel mimic diagram adjacent to the LCD display with LED status indicating lights to indicate the following:
 - a. ATS is in Source 1 position.
 - b. ATS is in Source 2 position.
 - c. Controller operating status.
 - d. Source 1 availability.
 - e. Source 2 availability.
 - f. Selected preferred source (where applicable).
10. Controller keypads shall include, as a minimum, the following:
 - a. Arrow/navigation buttons (permitting navigation of all status, metering, and configurable functions/parameters in conjunction with the LCD display).
 - b. Password-protected engine test button to initiate a keypad-configurable test sequence with adjustable test duration and "no load" (switch will not transfer) or "load" (switch will transfer) options.
 - c. Bypass time delay button (reduces programmed source-to-source transfer time delays to zero).
 - d. Lamp (LED) test button.

- e. Alarm reset button (or navigable onscreen reset for controllers with full color LCD display).
11. Controllers shall include, as a minimum, keypad-configurable three-phase sensing and pickup/dropout of over/under voltage, over/under frequency, phase rotation/sequence, and phase unbalance on both Source 1 and Source 2. Operation outside the pickup/dropout range for any listed condition shall render the affected source as “unavailable.” Reference the “Sequence of Operation” section herein for descriptions of minimum required automatic transfer functionality. Adjustable parameter factory-set initial values shall be as follows:
- a. Undervoltage: Pickup at 90% and dropout at 85% of rated voltage.
 - b. Overvoltage: Pickup at 105% and dropout out at 110% of rated voltage.
 - c. Underfrequency: Pickup at 94% and dropout at 96% of rated frequency.
 - d. Overfrequency: Pickup at 103% and dropout at 105% of rated frequency.
 - e. Voltage Unbalance: Pickup at 10% and dropout at 20% voltage unbalance, with time delay as specified herein.
 - f. Phase sequence/reversal (enabled).
12. Controllers shall include, as a minimum, the keypad-configurable time delay functions specified herein. Reference the “Sequence of Operation” section herein for descriptions of minimum required automatic transfer functionality. Adjustable parameter ranges and factory-set initial values shall be as follows (the specified initial values are not intended to reflect the factory default settings, but shall be the custom settings applied to each respective ATS supplied for this Project):
- a. Generator/Engine start time delay (for override of momentary Source 1 power outages/fluctuations before starting a Source 2 generator/engine via a relay output as specified herein). Programmable 0-120 seconds. Factory set at 0 seconds (disable).
 - b. Time delay on transfer from Source 1 to Source 2 (after loss of Source 1 availability and once Source 2 is confirmed available), programmable 0-1800 seconds. Factory set at 3 seconds.
 - c. Time delay on re-transfer from Source 2 back to Source 1 (after Source 1 is confirmed available to ensure stabilization of the source), programmable 0-1800 seconds. Factory set at 300 seconds.

- d. Pre-transfer time delay (additional/final delay with relay output as specified herein for pre-transfer operations prior to transferring in either direction), programmable 0-120 seconds. Factory set at 0 seconds (disable).
 - e. Time delay in center "OFF" position (ATS pauses in center "OFF" position for open-delayed transition when transferring in either direction), programmable 0-120 seconds. Factory set at 3 seconds.
 - f. Time delay for voltage unbalance (upon sensing of voltage unbalance as specified herein to declare failure/unavailable of Source 1 or Source 2), programmable 10-30 seconds. Factory set at 20 seconds.
 - g. Time delay on generator/engine failure (for override of momentary Source 2 generator/engine fluctuations before initiating the re-transfer to Source 1 sequence), programmable 0-6 seconds. Factory set at 0 seconds (disable).
 - h. Generator/engine cooldown time delay (Source 2 generator/engine continues running unloaded before stopping after re-transfer back to Source 1). Programmable 0-1800 seconds. Factory set at 0 seconds (disable).
13. Controllers shall include, as a minimum, a keypad-configurable programmable plant exerciser feature with the following functions:
- a. Exerciser interval (off, 1-day, 7-day, 14-day, or 28-day).
 - b. Exerciser day-of-week designation (Mon-Sun).
 - c. Exerciser load setting for either "no load" (switch will not transfer) or "load" (switch will transfer) during the exercise period.
 - d. Exerciser duration (up to 24 hour duration, adjustable in 1-hour and 1-minute increments).

14. Controllers shall be capable, as a minimum, of storing the following records in memory for access either locally or remotely:
 - a. Date of record reset.
 - b. Number of hours the transfer switch is in the Source 1 and Source 2 (total since record reset).
 - c. Number of hours Source 1 and Source 2 are available (total since record reset).
 - d. Total transfer in either direction (total since record reset).
 - e. Date, time, and description of the last four source failures.
 - f. Date of the last exercise period.
15. Controllers shall, as a minimum, meet the following requirements:

Storage conditions:	-25°C to 85°C
Operation conditions:	-20°C to 70°C ambient
Humidity:	0 to 95% relative humidity (non-condensing)
Capable of withstanding infinite power interruptions	
Surge withstand per IEEE C37.90.1	

1. Controllers shall, as a minimum, include the following relay outputs (either pre-defined or utilizing programmable outputs on the controller) wired to a terminal strip for connection of field wiring (all outputs shall be Form C dry contacts, rated 10 A at 250 VAC):
 - a. Source 1 Available
 - b. Source 2 Available
 - c. Source 1 Position/Closed
 - d. Source 2 Position/Closed
 - e. Pre-Transfer: Activates during pre-transfer time delay.
 - f. Generator/Engine Start: Activates on failure of the normal/preferred source (Source 1) to initiate generator (Source 2) engine starting.
 - g. ATS Fail/Alarm

2. All control wiring shall be 16 gauge (minimum), 600 VAC, SIS switchboard type. All control wiring shall be identified at each termination (both ends) using tubular, sleeve-type wire markers.

E. Surge Protective Devices

1. Where indicated on the Drawings, or as required for service entrance equipment, ATS shall be provided with integral surge protection device(s) (SPDs). Integral SPDs shall meet the applicable requirements of Section 26 43 13 – Surge Protective Devices.

F. Sequence of Operation

1. Reference the “Controls” section herein for definition of “Source 1” and “Source 2” for each ATS type, and for descriptions of required protective and operational functions. The voltage, frequency, and phase sequence pickups/dropouts (and resulting source “available” status) and the transfer/operational time delays referenced in the sequence of operations descriptions below shall have the adjustable setting ranges and the factory-set initial values as described in the “Controls” section herein.
2. The ATS shall operate normally on Source 1. After loss of Source 1 availability, the ATS controller shall execute the following sequence of time delays and actions:
 - a. Where applicable and specified herein to be enabled: Execute generator/engine start time delay then operate generator/engine start output relay.
 - b. Confirm Source 2 availability.
 - c. Execute time delay on transfer from Source 1 to Source 2.
 - d. Where applicable and specified herein to be enabled: Operate pre-transfer output relay and execute pre-transfer time delay.
 - e. Open Source 1 contacts and execute center “OFF” position time delay.
 - f. Close Source 2 contacts to complete transfer of the Load to Source 2.

3. When the ATS is operating on Source 2, the ATS controller shall monitor for restoration of Source 1 availability. After confirmation of Source 1 availability, the ATS controller shall execute the following sequence of time delays and actions:
 - a. Execute time delay on re-transfer from Source 2 to Source 1 with the following additional conditions:
 - 1) In the event that Source 2 becomes unavailable/fails during this time delay period, the ATS shall bypass this time delay and immediately proceed with the next step in the re-transfer sequence.
 - 2) Where applicable and specified herein to be enabled: For systems where Source 2 is a generator/engine, a time delay on generator/engine failure shall be active any time the load is connected to Source 2. When Source 2 is not operating within normal ranges, the time delay shall be executed to allow for generator/engine fluctuations, after which Source 2 shall be designated as unavailable/failed.
 - b. Where applicable and specified herein to be enabled: Operate pre-transfer output relay and execute pre-transfer time delay.
 - c. Open Source 2 contacts and execute center "OFF" position time delay.
 - d. Close Source 1 contacts to complete re-transfer of the Load to Source 1.
 - e. Where applicable and specified herein to be enabled: Execute generator/engine cooldown time delay then reset generator/engine start output relay to stop the generator/engine.

PART 3 – EXECUTION

3.01 INSTALLATION

- A. Each ATS shall be installed as shown on the Drawings and in accordance with the manufacturer's installation instructions.
- B. Each ATS shall be provided with adequate lifting means for installation of wall or floor mounted enclosures.
- C. Install each ATS to allow complete door swing required for component removal. This is critical where an ATS is set next to a wall on the door-hinge side of the enclosure.

3.02 PAINTING

- A. Prior to final completion of the work, all metal surfaces of the equipment shall be cleaned thoroughly, and all scratches and abrasions shall be retouched with the same coating as used for factory finishing coats.

3.03 TESTING

- A. All tests shall be performed in accordance with the requirements of the General Conditions and Division 01. The following tests are required:
 - 1. Witnessed Shop Tests
 - a. None required.
 - 2. Certified Shop Tests and Reports
 - a. Automatic transfer switches shall be given routine factory tests. The factory tests shall demonstrate that the completed switches function correctly and that the required timing has been set.
 - b. Submit notarized and certified copies of all test reports.
 - c. Test procedures shall be in accordance with UL 1008. During the three-cycle withstand tests, there shall be no contact welding or damage.
 - d. The three-cycle tests shall be performed without the use of current limiting fuses.
 - e. Oscillograph traces across the main contacts shall verify that contact separation has not occurred and there is contact continuity across all phases after completion of the test.
 - f. When conducting temperature rise tests in accordance with UL 1008, include post-endurance temperature rise tests to verify the ability of the transfer switch to carry full rated current after completing the overload and endurance tests.
 - g. Manufacturer shall submit test reports upon request.
 - 3. Field Tests
 - a. Field testing shall be done in accordance with the requirements specified in the General Conditions, Division 01, NETA Acceptance Testing Specifications, and Section 26 05 00 – Basic Electrical Requirements.

- b. Prior to acceptance of the installation, load test the equipment with all available motor load, but do not exceed ATS' nameplate rating. Correct defects which become evident during this test.

3.04 SERVICES OF MANUFACTURER'S REPRESENTATIVE

- A. The Contractor shall provide the services of a qualified manufacturer's factory-trained technical representative who shall adequately supervise the installation and startup of all equipment furnished under this Contract. The manufacturer's representative shall certify in writing that the equipment has been installed in accordance with the manufacturer's recommendations. No further testing or equipment startup may take place until this certification is accepted by the Owner.
- B. The manufacturer's technical representative shall perform all startup and field acceptance testing as specified herein.
- C. The Contractor shall provide training for the Owner's personnel. Training shall be conducted by the manufacturer's factory-trained representative who shall instruct Owner's personnel in operation and maintenance of all equipment provided under this Section. Training shall be provided for two (2) sessions of two (2) hours each. Training shall not take place until after the ATS have been installed and tested. Training shall be conducted at times coordinated with the Owner.
- D. The services of the manufacturer's representative shall be provided for a period of not less than as follows:
 - 1. For each ATS: One (1) trip of one (1) working day during installation of the ATS.
 - 2. For each ATS acting as service entrance equipment: One (1) trip of one (1) working day to perform startup and field acceptance testing of the ATS.
 - 3. One (1) trip of one (1) working day to perform training as specified herein.
 - 4. One (1) trip of one (1) working day two (2) months before the expiration of the warranty to identify any issues to be corrected under warranty.
- E. Any additional time required to achieve successful installation and operation shall be at the expense of the Contractor.

END OF SECTION

L&O STORM SEWER STRUCTURE SCHEDULE			
STRUCTURE NAME:	DETAILS:	CONNECTED PIPES:	COORDINATES:
CBI-08 2'X3' CURB BOX INLET	LINE - 04 STA 40+62 RIM: 338.97 DEPTH: 6.47'	INV IN: 332.50 18" SD (HDPE) (NE) INV OUT: 332.50 18" SD (RCP)(W)	N: 690241.19 E: 2043828.28
CBI-09 2'X3' CURB BOX INLET	LINE - 04 STA 41+33 RIM: 344.38 DEPTH: 8.58'	INV IN: 335.80 18" SD (HDPE) (N) INV OUT: 335.80 18" SD (HDPE)(SW)	N: 690291.31 E: 2043879.39
CBI-10 2'X3' CURB BOX INLET	LINE - 04 STA 42+31 RIM: 344.60 DEPTH: 7.42'	INV IN: 340.26 15" SD (HDPE) (NE) INV IN: 337.38 15" SD (HDPE) (NW) INV OUT: 337.18 18" SD (HDPE)(S)	N: 690388.48 E: 2043874.08
CBI-11 2'X3' CURB BOX INLET	LINE - 04 STA 42+81 RIM: 347.65 DEPTH: 4.17'	INV IN: 343.48 15" SD (HDPE) (NE) INV IN: 343.94 8" SD (HDPE) (SE) INV OUT: 343.48 15" SD (HDPE)(SW)	N: 690412.68 E: 2043918.82
CBI-12 2'X3' CURB BOX INLET (DOUBLE INLET)	LINE - 04 STA 44+33 RIM: 349.01 DEPTH: 4.01'	INV OUT: 345.00 15" SD (HDPE)(SW)	N: 690510.84 E: 2044034.20
CBI-13 2'X3' CURB BOX INLET	LINE - 05 STA 50+63 RIM: 341.20 DEPTH: 3.50'	INV OUT: 337.70 15" SD (HDPE)(SE)	N: 690425.19 E: 2043822.47
OUT-02 3'X3' OUTLET STRUCTURE	LINE - 01 STA 11+82 RIM: 316.50 DEPTH: 7.50'	INV OUT: 309.00 24" SD (RCP)(S)	N: 689752.46 E: 2043588.75
OUT-06 3'X3' OUTLET STRUCTURE	LINE - 03 STA 30+98 RIM: 335.00 DEPTH: 9.00'	INV OUT: 326.00 18" SD (RCP)(W)	N: 690241.19 E: 2043892.42

HEADWALL STRUCTURE SCHEDULE			
STRUCTURE NAME:	DETAILS:	CONNECTED PIPES:	COORDINATES:
HW-01	LINE - 01 STA 11+14	INV IN: 308.64 24" SD (RCP)(N)	N: 689685.09 E: 2043588.75
HW-03	LINE - 02 STA 20+41	INV IN: 317.35 15" SD (HDPE)(NE)	N: 689856.06 E: 2043844.91
HW-04	LINE - 02 STA 20+81	INV OUT: 318.15 15" SD (HDPE) (SW)	N: 689882.55 E: 2043874.93
HW-05	LINE - 03 STA 30+17	INV IN: 323.85 18" SD (RCP)(E)	N: 690241.19 E: 2043611.45
HW-07	LINE - 04 STA 40+34	INV IN: 332.00 18" SD (RCP)(E)	N: 690241.19 E: 2043800.72

STORM SEWER PIPE TABLE				
PIPE NUMBER	SIZE	MATERIAL	LENGTH	SLOPE
01-02	24"	RCP	67.37'	0.53%
03-04	15"	CPP	40.04'	2.00%
05-06	18"	RCP	80.97'	2.65%
07-08	15"	RCP	27.56'	1.82%
08-09	18"	HDPE	71.58'	4.61%
09-10	18"	HDPE	97.32'	1.42%
10-11	15"	HDPE	50.87'	6.34%
10-13	15"	HDPE	63.33'	0.50%
11-12	15"	HDPE	151.48'	1.00%

L&O SANITARY SEWER STRUCTURE SCHEDULE			
STRUCTURE NAME:	DETAILS:	CONNECTED PIPES:	COORDINATES:
CO-05	LINE - A STA 4+30 RIM: 351.17 DEPTH: 4.15'	INV OUT: 347.02 (6" PVC) (SW)	N: 690303.05 E: 2044032.93
EX MH-15 [DROP]	LINE - A STA 0+00 RIM: 330.65 DEPTH: 19.51'	INV IN: 322.60 (8" PVC) (N) INV IN: 311.38 (16" DI) (W) INV OUT: 311.14 (16" DI) (S)	N: 690117.11 E: 2044219.28
SAN MH-01	LINE - A STA 0+62 RIM: 333.04 DEPTH: 9.81'	INV IN: 323.32 (8" PVC) (W) INV OUT: 323.22 (8" PVC) (S)	N: 690179.29 E: 2044219.28
SAN MH-02	LINE - A STA 2+67 RIM: 338.93 DEPTH: 13.55'	INV IN: 325.47 (8" PVC) (NW) INV OUT: 325.37 (8" PVC) (E)	N: 690179.29 E: 2044014.28
SAN MH-03 [DROP]	LINE - A STA 3+12 RIM: 340.47 DEPTH: 14.54'	INV IN: 331.74 (8" PVC) (N) INV OUT: 325.92 (8" PVC) (SE)	N: 690218.33 E: 2043991.74
SAN MH-04 [DROP]	LINE - A STA 3+67 RIM: 332.87 DEPTH: 15.62'	INV IN: 345.46 (6" PVC) (NE) INV IN: 349.72 (4" PVC) (NW) INV OUT: 337.25 (8" PVC) (S)	N: 690271.89 E: 2043978.94

SANITARY SEWER PIPE TABLE				
PIPE NUMBER	SIZE	MATERIAL	LENGTH	SLOPE
01-02	8"	PVC	205.00'	1.00%
02-03	8"	PVC	45.08'	1.00%
03-04	8"	PVC	55.07'	10.00%
05-06	6"	PVC	62.34'	2.50%
EX-01	8"	PVC	62.18'	1.00%

NOTE:

- COORDINATES SHOWN IN STRUCTURE TABLE ARE TO THE CENTER OF STRUCTURE (0.5' FROM FACE OF CURB FOR CURB BOX INLETS). COORDINATES FOR HEADWALLS ARE AT THE END OF THE PIPE.
- THE CENTER OF STRUCTURE FOR MANHOLES IS THE CENTER OF THE BASE AND NOT THE LID.
- PIPE LENGTHS SHOWN ARE FROM CENTER OF STRUCTURE TO CENTER OF STRUCTURE.
- ALL DROP MANHOLES SHALL BE OUTSIDE DROPS (HS708) UNLESS OTHERWISE NOTED ON THESE CONSTRUCTION DRAWINGS.

ALIGNMENT HORIZONTAL CONTROL TABLES

LINE A TABLE		
ALIGNMENT POINT	NORTHING	EASTING
LINE A POB	690117.11	2044219.28
LINE A PI 01	690179.29	2044219.28
LINE A PI 02	690179.29	2044014.28
LINE A PI 03	690271.89	2043978.94
LINE A POE	690303.05	2044032.93

LINE 01 TABLE		
ALIGNMENT POINT	NORTHING	EASTING
LINE 01 POB	689570.59	2043588.75
LINE 01 POE	689768.29	2043588.75

LINE 02 TABLE		
ALIGNMENT POINT	NORTHING	EASTING
LINE 02 POB	689816.15	2043841.55
LINE 02 PI	689853.08	2043841.55
LINE 02 POE	689894.81	2043888.84

LINE 03 TABLE		
ALIGNMENT POINT	NORTHING	EASTING
LINE 03 POB	690241.19	2043594.28
LINE 03 POE	690241.19	2043751.72

LINE 04 TABLE		
ALIGNMENT POINT	NORTHING	EASTING
LINE 04 POB	690241.19	2043766.68
LINE 04 PI 01	690241.19	2043828.28
LINE 04 PI 02	690291.31	2043879.39
LINE 04 PI 03	690388.48	2043874.08
LINE 04 PI 04	690412.68	2043918.82
LINE 04 PI 05	690512.14	2044033.45
LINE 04 POE	690525.39	2044056.44

LINE 05 TABLE		
ALIGNMENT POINT	NORTHING	EASTING
LINE 05 POB	690388.48	2043874.08
LINE 05 POE	690425.19	2043822.47

POTABLE WATER LINE TABLE		
ALIGNMENT POINT	NORTHING	EASTING
PW BOP	690084.22	2043847.78
PW PI 01	690301.04	2043847.78
PW PI 02	690341.57	2043858.64
PW PI 03	690451.66	2044049.33
PW PI 04	690427.16	2044143.68
PW EOP	690422.26	2044230.49

File: C:\USERS\PEREZ\DRAWINGS\HAZEN AND SAWYER\31407-006 UTILEY CREEK WRF BMSD EXPANSION\PROJECT FILES\01_DESIGN\CIVIL\EARLY WORK\PACKAGES\LABS AND OPERATORS BLDGS\1407-006 C008 Saved by JPEREZ Save date: 5/22/2025 11:59 AM
PLOT DATE: 5/22/2025 2:31 PM BY: JPEREZ

PROJECT ENGINEER:	D. WANKMULLER
DESIGNED BY:	W. ELLIS
DRAWN BY:	J. PEREZ
CHECKED BY:	D. SKEGGS
IF THIS BAR DOES NOT MEASURE 1" THEN DRAWING IS NOT TO FULL SCALE	0 1/2" 1"
1 BID ADDENDUM NO. 2	05/23/25 DS
REV ISSUED FOR	DATE BY

ISSUED FOR CONSTRUCTION



Hazen
HAZEN AND SAWYER
4011 WESTCHASE BOULEVARD, SUITE 500
RALEIGH, NORTH CAROLINA 27607
LICENSE NO.: C-0381
TELEPHONE NO.: (919) 833-7152

TOWN OF HOLLY SPRINGS
HOLLY SPRINGS, NORTH CAROLINA

UTILEY CREEK WRF
LAB & OPERATORS BUILDING

CIVIL
TABLE AND DATA SHEET

DATE:	APRIL 2025
HAZEN NO.:	31407-006
CONTRACT NO.:	--
DRAWING NUMBER:	C008

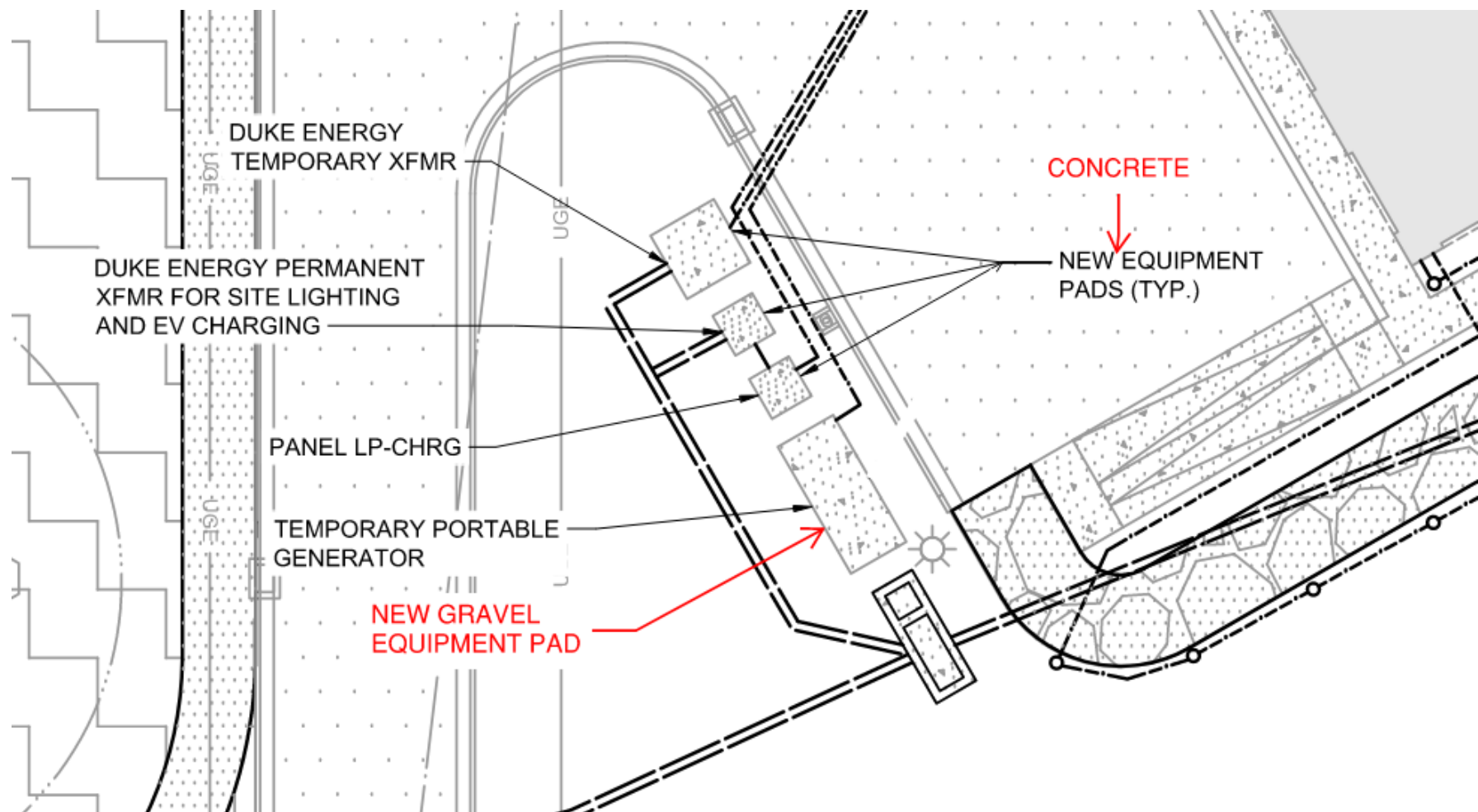

ADDENDUM NO.	DATE	<p style="text-align: center;">TOWN OF HOLLY SPRINGS HOLLY SPRINGS, NORTH CAROLINA</p>	HAZEN JOB NUMBER 31407-006	REFER TO CONTRACT DRAWING NUMBER
ATTACHMENT NO.	BY		<p style="text-align: center;">UTLEY CREEK WRF LAB AND OPERATORS BUILDING</p>	CONTRACT NUMBER --

NOTES

1. THE CONTRACTOR SHALL PROVIDE (2) #14, #14GND, 3/4"C TO EACH OF THE FOLLOWING LOADS TO BE SHED DURING GENERATOR OPERATION. LOADS SHALL INCLUDE:

- A. WATER HEATER WH-800-2
- B. BOD FUME HOOD NO. 1
- C. BOD FUME HOOD NO. 2
- D. BUILDING AUTOMATION SYSTEM 'BMS PANEL'

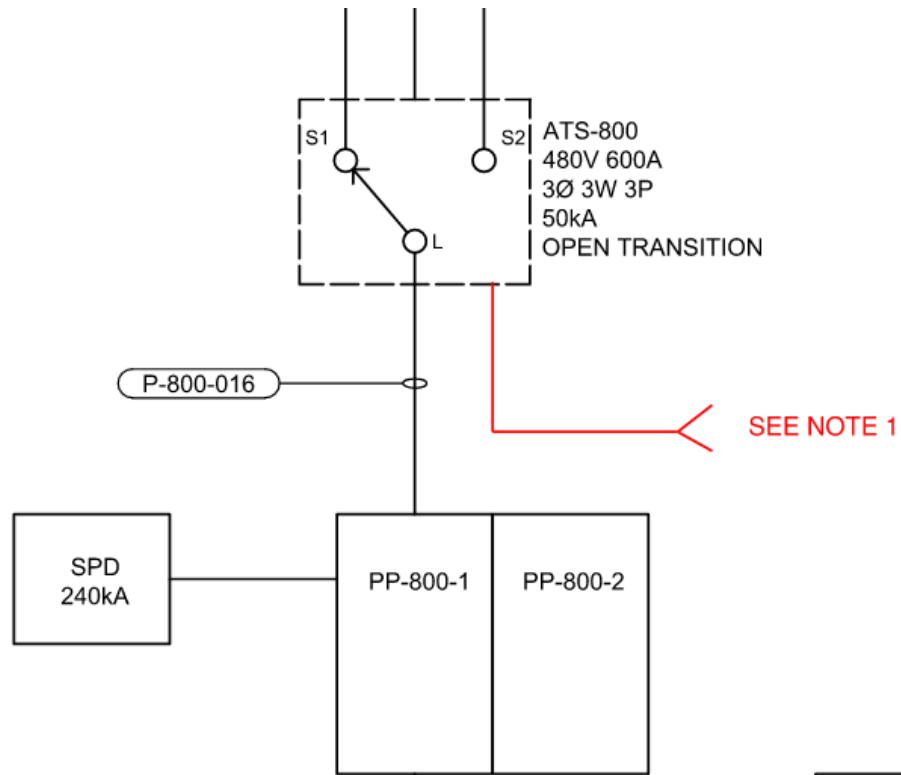

ADDENDUM NO.	DATE	TOWN OF HOLLY SPRINGS HOLLY SPRINGS, NORTH CAROLINA	HAZEN JOB NUMBER 31407-006	REFER TO CONTRACT DRAWING NUMBER
ATTACHMENT NO.	BY	UTLEY CREEK WRF LAB AND OPERATORS BUILDING	CONTRACT NUMBER --	SHEET OF

AN AGREEMENT BETWEEN THE ENGINEER OF RECORD AND CONTRACTOR
FOR TRANSFER OF BIM (BUILDING INFORMATION MODELING) AND/OR CAD
(COMPUTER AIDED DRAFTING) FILES ON ELECTRONIC MEDIA

Engineer of Record (Engineer):

Contractor:

Project Number:

Date:

Project Name:

Owner/Location:

The Engineer will provide the CAD and/or BIM files, described as follows, for the convenience of the Contractor:

The Contractor shall pay the Engineer a service fee of:

TERMS AND CONDITIONS

1. Engineer makes no representation as to the compatibility of the CAD and/or BIM files with any hardware or software.
2. Since the information set forth on the CAD and/or BIM files can be modified unintentionally or otherwise, the Engineer reserves the right to remove all indicia of its ownership and/or involvement from each electronic CAD and/or BIM file.
3. All information on the CAD and/or BIM files is considered instruments of service of the Engineer and shall not be used for other projects, for additions to this project, or completion of this project by others. The CAD and/or BIM files shall remain the property of the Engineer, and in no case shall the transfer of these files be considered a sale.
4. The Engineer makes no representation regarding the accuracy, completeness, or permanence of the CAD and/or BIM files, nor for their merchantability or fitness for a particular purpose. Addenda information or revisions made after the dates indicated on the CAD and/or BIM files may not have been incorporated. In the event of a conflict between the Engineer's original sealed contract bid documents and the CAD and/or BIM files, the original contract bid documents shall govern. It is the Contractor's responsibility to determine if any conflicts exist. The CAD and/or BIM files shall not be considered Contract Documents as defined by the General Conditions of the Contract for Construction.

5. The use of CAD and/or BIM files prepared by the Engineer shall not in any way obviate the Contractor's responsibility for the proper checking and coordination of dimensions, details, quantities of materials and equipment as required to facilitate completion of the Contract for Construction.
6. The Contractor shall, to the fullest extent permitted by law, indemnify, defend and hold harmless the Engineer and its subconsultants from all claims, damages, losses, expenses, penalties and liabilities of any kind, including attorney's fees, arising out of or resulting from the use of the CAD and/or BIM files by the Contractor, or by third party recipients of the CAD and/or BIM files from the Contractor.
7. The Engineer believes that no licensing or copyright fees are due to others on account of the transfer of the CAD and/or BIM files, but to the extent any are, the Contractor shall pay the appropriate fees and hold the Engineer harmless from such claims.
8. Payment of service fees, if included above, is due upon receipt of the CAD and/or BIM files.
9. This agreement shall be governed by the laws of the state of .

AUTHORIZED ACCEPTANCE

Engineer of Record

Contractor

Signature

Signature

Name: _____

Name: _____

Title: _____

Title: _____

Date: _____

Date: _____