



## **Informal Bid**

**#274-2025-110-FM**

**Bid Title: Ammunition Magazine Bunker**

Notice is hereby given that the City of Raleigh, North Carolina, is seeking bids. This contract is for a one-time purchase.

**BIDS WILL BE ACCEPTED UNTIL 2:00 PM (EDT), Tuesday March 4th, 2025**

Bids may be emailed directly to: [Felicia.Moye@raleighnc.gov](mailto:Felicia.Moye@raleighnc.gov)

Hardcopy Bids Should be Labeled as:  
City of Raleigh – Finance/Procurement  
Attn: Felicia Moye – Procurement Analyst

Hand-Deliver to: 222 W. Hargett Street, 5<sup>th</sup> Floor, Ste. 502, Raleigh, NC 27601

or Mail to: PO Box 590, Raleigh, NC 27602-0590

or

Electronic responses will be accepted for this solicitation. See page 9 for instructions.

**The responsibility for submitting a response to this Informal Bid at the City of Raleigh, Procurement Division on or before the stipulated time and date will be solely and strictly the responsibility of the bidder. Any proposals received after stipulated time and date will not be accepted. The time stamp located in the Procurement Division shall be the official time of receipt.**

**City of Raleigh**  
**Ammunition Magazine Bunker**  
**BID Request No: 274-2025-110-FM**

**BID FORM**

Quantity	Unit of Measure	Item Description	Unit Price	Extended Price
1	Each	Ammunition Magazine Bunker	\$ _____	\$ _____
			<b>Delivery</b>	\$ _____
<b>Total Bid Amount</b>				\$ _____ <b>FOB DESTINATION</b>
<b>Warranty Information:</b>				
<b>Delivery Lead Time:</b>				

INSTRUCTIONS TO BIDDERS: Bidders must provide Manufacturer, Make/Model Number, Warranty length, and the anticipated timeframe for delivery upon receipt of a City purchase order. Total Bid Amount includes ALL fees and costs related to product delivery less taxes. Do not include taxes in your bid pricing. Any and all tax imposed upon any article on which you are bidding are only to be shown as separate line items on invoices, and in no case are taxes to be included with your bid price. Failure to comply with these conditions will be considered grounds for rejection.

---

**EMAIL AND FAX COPIES OF BIDS ARE NOT ACCEPTABLE**  
**POSITIVELY NO BIDS CONSIDERED UNLESS SUBMITTED ON THIS FORM**

COMPANY: \_\_\_\_\_

DATE: \_\_\_\_\_

AUTHORIZED SIGNATURE: \_\_\_\_\_

TITLE: \_\_\_\_\_

**PRODUCT SPECIFICATIONS:**

Type II Outdoor Magazine (Per ATF guidelines)

**Construction:** The exterior and doors constructed of minimum 1/4" ASTM A-36 prime plate steel lined with 3" inches of hardwood. Outdoor magazine is to be bullet-resistant, fire-resistant, weather-resistant, theft-resistant, and ventilated. They are to be supported to prevent direct contact with the ground and, if less than one cubic yard in size, must be securely fastened to a fixed object. Open channel base construction and lifting lugs included. Additional flooring supports to increase floor load.

**Exterior Construction:** The exterior and doors are to be constructed of not less than 1/4-inch steel and lined with at least two inches of hardwood. Magazine with top openings will have lids with water-resistant seals or which overlap the sides by at least one inch when in a closed position. Hinges and hasps are to be attached to doors by welding, riveting, or bolting (nuts on inside of door). Hinges and hasps must be installed so that they cannot be removed when the doors are closed and locked. The unit should have two slots for two different pad locks to be used to lock the main door.

Install gravity airflow vents with steel hoods to provide adequate air flow and natural draft ventilation.

**Magazine Finish:** Interior and Exterior steel surfaces protected with a high performance modified phenolic alkyd resin base coat (primer) and an acrylic alkyd enamel topcoat providing proven interior chemical resistance as well as exterior abrasion, corrosion and UV resistance.

Bare Weight: +/- 8,900 Lbs.

Exterior Dimensions: 132" x 84" x 84"

Actual Interior Dimensions: 125.5" x 77.5" x 80"

**Accessories to be installed:****Install Square D Load center, 8 spaces**

UL listed, single phase, 3 wire, 120/240v, 8 space load center that is rainproof and sleet- (ice) resistant- outdoor to protect the enclosed equipment against rain and meet the requirements of underwriters' laboratories, inc., publication no. ul 508

**Static Grounding System:**

One (1) Exterior static grounding connection and one (1) eight foot (8') long galvanized steel grounding rod provided to meet NFPA 70.

**LED light fixture**

Install (1) LED light fixture, ceiling or wall mount, round light. Designed for use in hazardous locations and where moisture, dirt, dust, corrosion and vibration may be present.

**Air Conditioner**

Install (1) UL/ULC listed air-conditioner, cooling is 15,700 btu with integral thermostat, 230/208v 60 hz operation

**A/C Hood 1**

Install (1) Hood for air conditioner, bullet resistant

**Shelf 1**

Install (1) non-sparking shelf back wall 1 tier, 16" deep

REMAINDER OF THIS PAGE LEFT BLANK INTENTIONALLY

Ammunition Magazine Bunker			
Meets or Exceeds Requirements Below		Yes	No
A	Type II Outdoor Magazine meet the construction requirements in <a href="#">27 CFR § 555.208</a> .		
B	Exterior Dimensions: 132" x 84" x 84"		
C	Bare Weight: +/- 8,900 Lbs		
D	Actual Interior Dimensions: 125.5" x 77.5" x 80"		
E	4-6 weeks lead time for delivery		
	Please list any exceptions		

REMAINDER OF THIS PAGE LEFT BLANK INTENTIONALLY

EXAMPLE

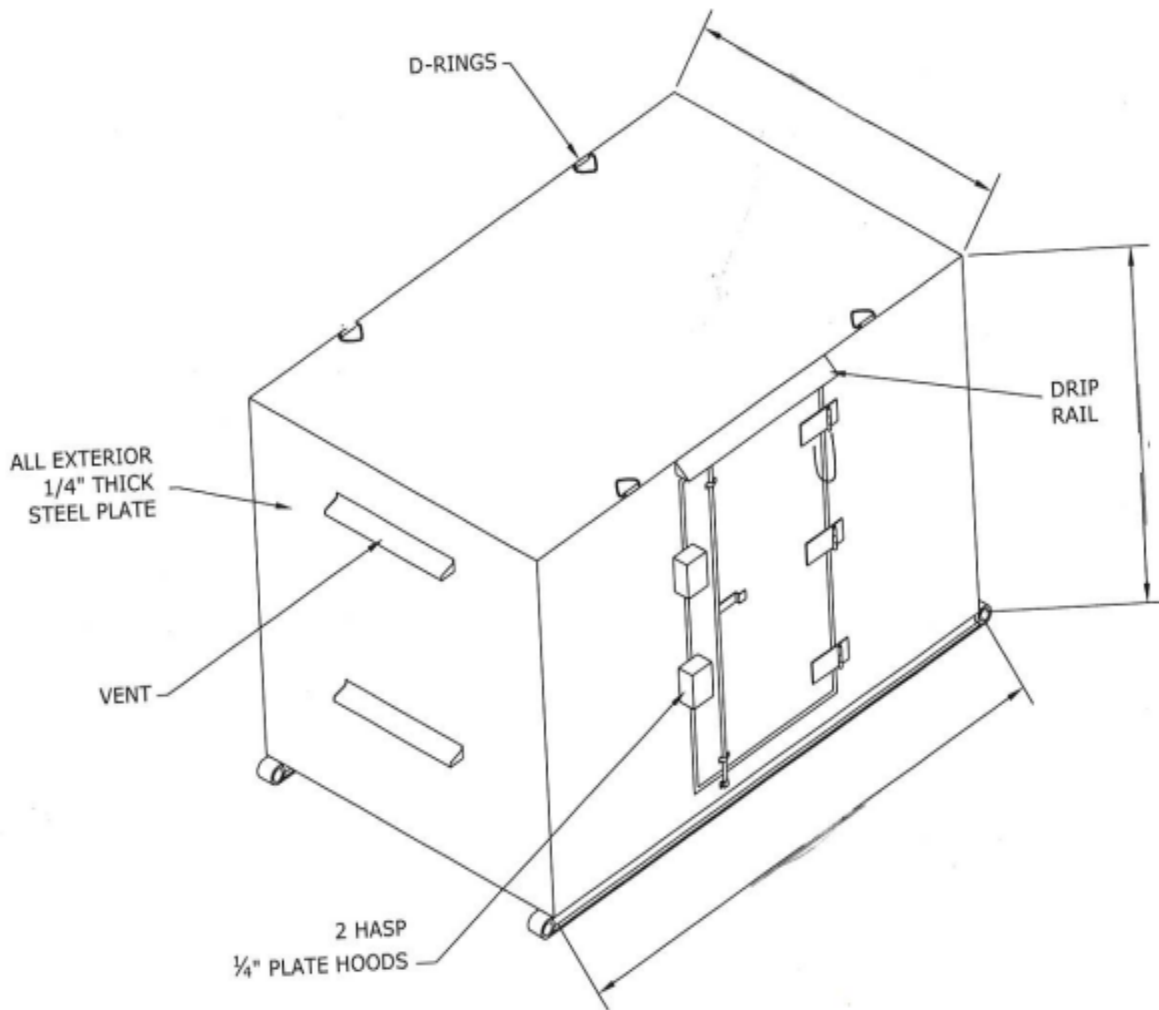



**CITY OF RALEIGH  
NON-DISCRIMINATION ASSURANCES**

To the extent permitted by North Carolina law, the parties hereto for themselves, their agents, officials, employees and servants agree not to discriminate in any manner on the basis of race, color, creed, national origin, sex, age, handicap, or sexual orientation with reference to the subject matter of this Contract. The parties further agree, to the extent permitted by law, to conform with the provisions and intent of City of Raleigh Ordinance 1969-889, as amended. This provision is hereby incorporated into this Contract for the benefit of the City of Raleigh and its residents, and may be enforced by action for specific performance, injunctive relief, or other remedy as provided by law. This provision shall be binding on the successors and assigns of the parties with reference to the subject matter of this Contract.

SIGNATURE: \_\_\_\_\_  
(President/Authorized Officer)

TITLE: \_\_\_\_\_

DATE: \_\_\_\_\_



**CITY OF RALEIGH  
INSTRUCTIONS TO BIDDERS**

**PURPOSE:**

The purpose of this document is to provide general and specific information for the use by vendors in submitting a bid to supply the City of Raleigh with apparatus, supplies, material and equipment, and /or services listed above. Some bids are governed by Section 143-129, of the North Carolina General Statutes.

**BID SCHEDULE:**

Listed below are the dates and times by which stated actions must be taken or completed. The City may determine, in its sole discretion, that it is necessary to change any of these dates and times. All listed times are Eastern standard times.

Action	Time	Date
Bid issued		February 17, 2025
Pre-Bid Conference		N/A
Deadline for Questions	12:00 PM	February 24, 2025
Bids Due	2:00 PM	March 04, 2025
Anticipated Award		

**HOW TO PREPARE INFORMAL BIDS:**

Bidders are encouraged to review carefully all provisions and attachments of this document prior to completion. Each bid constitutes an offer and may not be withdrawn except as provided herein. Also, prices are to remain firm for the period stated herein.

1. All informal bids must be submitted on the document(s) provided herein and signed by the vendor or his authorized representative with all erasures or corrections initialed and dated by the Official authorized representative of the proposal.
2. All informal bids must be signed by an authorized official of the firm. A bid may be rejected if it shows omissions, alterations of form, additions not called for, conditional bid, or any irregularities.
3. **TAXES: Do not include taxes in your bid figures.** The City pays sales tax and you should add this to your bid figures separately when invoices are paid. The City is exempt from Federal Excise Tax and has a Federal Tax number.
4. **NON-DISCRIMINATION:** The **NON-DISCRIMINATION ASSURANCES** form included in the bid package is a condition of the bid and must be completed and signed by the bidder.
5. **MWBE POLICY:** The City of Raleigh prohibits discrimination in any manner on the basis of race, color, creed, national origin, sex, age or handicap or sexual orientation and will pursue an affirmative policy of fostering, promoting and conducting business with women and minority owned business enterprises. The City of Raleigh encourages participation by certified minority and women-owned businesses. If there are any questions, Contact the MWBE Program Manager, PO BOX 590 Raleigh, NC 27602, [mwbe@raleighnc.gov](mailto:mwbe@raleighnc.gov), or 919-996-4330.

6. **SUSTAINABILITY:** The City recognizes that the types of products and services the City buys have inherent social, human health, environmental and economic impacts, and asks that all vendors and bidders providing and proposing products and services to the City, be mindful of the City’s Sustainability Policy and provide and propose products and services that embody the City’s commitment to sustainability whenever possible.
7. **Electronic responses** will be accepted for this solicitation. **You must be registered with NC’s eVP to submit a bid. Register as soon as possible! It may take 3 to 5 days for your account to become active. Please go to this page to register <https://eprocurement.nc.gov/training/vendor-training>.** For additional information, please view the following link: NC BIDS FAQs for Vendors <https://ncadmin.nc.gov/nc-bids-faqs-vendors> or email [vendor@nc.gov](mailto:vendor@nc.gov). Once you have registered and have your login and password set up, to find and respond to a solicitation, follow the instructions: [Viewing and Responding to Solicitations in eVP](#)

**AWARD OF BID**

1. **Standard for Acceptance of Informal Bid for Award Contract:** The City reserves the right to reject any or all bids and to waive any irregularities or technicalities in bids received whenever such rejection or waiver is in the best interest of the City of Raleigh. The award shall be made to the lowest responsible bidder or bidders taking into consideration, quality, performance, and the time specified in the proposal for the performance of the contract.
2. **Delivery:** All items are to be delivered **FOB destination, freight prepaid and allowed** to the location provided when ordered. All items are to be delivered safely, or shipped in a protective carton, fully assembled, and serviced ready for operation.
3. **Payment Terms:** Payment terms of Net 30 days from the date of receipt of invoice will apply to all invoices. Payment term discounts will be allowed for prompt payments, but will not be a consideration for award. All invoices are to be emailed to [accountspayable@raleighnc.gov](mailto:accountspayable@raleighnc.gov) or delivered to **City of Raleigh, Accounts Payable Division, PO Box 590, Raleigh, NC 27602-0590.**
4. **How to Submit Informal Bids:** Informal Bids/Quotes shall be mailed or emailed to the bid agent indicated below.
5. **Contact:** Any and all questions, concerns, or request for additional information shall be directed to the City of Raleigh, Purchasing Division to the attention of the Bid Agent as indicated below:  

Bid Agent: Felicia Moye  
Procurement Analyst  
Email: Felicia.Moye@raleighnc.gov
6. **Terms and Conditions:** Acceptance of the City’s Purchase Order includes acceptance of all applicable Terms and Conditions. The City’s Purchase Order Terms & Conditions are provided below for your information.

REMAINDER OF THIS PAGE LEFT BLANK INTENTIONALLY



Rev. 02/07/19

## CITY OF RALEIGH PURCHASE ORDER TERMS & CONDITIONS

1. **Vendor quotes or proposals are referenced for scope only.** City of Raleigh Purchase Order Terms & Conditions exclusively governs this purchase.
2. All invoices are to be sent by email to: [accountspayable@raleighnc.gov](mailto:accountspayable@raleighnc.gov) . Or, mail or deliver all invoices to the **City of Raleigh, Accounts Payable, PO Box 590, Raleigh NC 27602-0590.**
3. **Important: All invoices must include a unique invoice number and this Purchase Order number.** Invoices submitted without the unique invoice number or without the correct purchase order number will result in delayed payment.
4. Invoices for partial deliveries must be indicated as such.
5. The Vendor must provide separate invoices for each Purchase Order number.
6. **The City of Raleigh is not exempt from North Carolina State Sales Tax, Wake County Sales Tax, and Wake County Prepared Meals and Hotel Room Taxes.** These taxes must be correctly invoiced to the City for payment. Taxes shown on the purchase order are approximate.
7. The City of Raleigh is exempt from Federal Excise Tax. If any form of such tax is billed on the invoice, it must be shown as a separate item. Tax Exemption Certificates will be furnished upon request.
8. Payment term discounts will be deducted as provided for on the front of this Purchase Order or in accordance with the terms of your official quotation or bid. **Net purchases will be paid 30 days from the date of your invoice, or upon acceptance of goods whichever is later.**
9. **Important: All packages must bear the correct Purchase Order number on the outside of each package or shipping container.**
10. The City of Raleigh will not be responsible for any goods delivered without a Purchase Order having been issued.
11. The conditions of this order cannot be modified except by written amendment in the form of a "Corrected Purchase Order" which has been approved by the City of Raleigh's Purchasing Manager.
12. Any rejected materials will be returned to the Vendor at the Vendor's risk and expense.
13. In the event of a Vendor's failure to deliver or perform as specified, the City reserves the right to cancel the order or any part thereof, without prejudice to its other rights. The Vendor agrees that the City may return part or all of any shipment and may charge the vendor with all reasonable losses or expenses sustained as a result of such failure to deliver or perform.
14. In case of default of the contractor, the City may procure the articles or services from other sources and charge the Vendor damages for any excess costs or other damages caused by the default.
15. It is agreed that the goods, materials, equipment or services provided shall comply with all Federal, State or local laws, and that the Vendor shall defend actions or claims brought, and save harmless the City, and/or its officials or employees, from loss, cost or damage by reason of actual or alleged failure to comply with such laws.
16. All prices must be F.O.B. Destination and delivered to the destination indicated on the front of the purchase order. Where specific purchase is quoted or negotiated F.O.B. Shipping Point, the vendor is to prepay the shipping charges and add them to the invoice.
17. The risk of loss and damage to the goods which are the subject of this order shall be the Vendor's until the goods are delivered to the destination set out in the order and accepted by the purchaser or its representative.
18. The Vendor acknowledges that it is the policy of the City of Raleigh to avoid commercial promotion of products used by the City or the vendors of such products. The Vendor accordingly agrees not to solicit, use, or disseminate commercial advertisement founded upon the City's purchase and/or use of the goods which are the subject of this order, and specifically agrees not to seek or use for advertising purposes the endorsement of goods or products by City officers or employees.
19. The City may, at any time, insist upon strict compliance with these terms and conditions, notwithstanding any previous customer, practice or course of dealing to the contrary. **Acceptance of the order includes acceptance of all terms, conditions, prices, delivery instructions and specifications as shown on this order or attached to and made a part of this order.**
20. All matters relating to this Purchase Order shall be governed by the laws of the State of North Carolina, without regard to its choice of law provisions, and venue for any action relating to this Contract shall be Wake County Civil Superior Court or the United States District Court for the Eastern District of North Carolina, Western Division.
21. Notwithstanding any other provisions of this Purchase Order, this Purchase Order and all materials submitted to the City by the Vendor are subject to the public records laws of the State of North Carolina and it is the responsibility of the Vendor to properly designate materials that may be protected from disclosure as trade secrets under North Carolina law as such and in the form required by law prior to the submission of such materials to the City. Vendor understands and agrees that the City may take any and all actions necessary to comply with federal, state, and local laws and/or judicial orders and such actions will not constitute a breach of the terms of this Purchase Order. To the extent that any other provisions of this Purchase Order conflict with this paragraph, the provisions of this section shall control.
22. **Non-discrimination** - To the extent permitted by North Carolina law, the parties hereto for themselves, their agents, officials, employees and servants agree not to discriminate in any manner on the basis of race, color, creed, national origin, sex, age, handicap, or sexual orientation with reference to the subject matter of this Contract. The parties further agree, to the extent permitted by law, to conform with the provisions and intent of City of Raleigh Ordinance 1969-889, as amended. This provision is hereby incorporated into this Contract for the benefit of the City of Raleigh and its residents, and may be enforced by action for specific performance, injunctive relief, or other remedy as provided by law. This provision shall be binding on the successors and assigns of the parties with reference to the subject matter of this Contract.

23. **Insurance** – If performing services under this Purchase Order the Vendor agrees to maintain, on a primary basis and at its sole expense, at all times during the life of this Purchase Order the following coverages and limits. The requirements contained herein, as well as City’s review or acceptance of insurance maintained by Vendor is not intended to and shall not in any manner limit or qualify the liabilities or obligations assumed by Vendor under this Purchase Order:
- a. **Workers’ Compensation Insurance** - Vendor agrees to maintain Worker’s Compensation Insurance in accordance with North Carolina General Statute Chapter 97 and with limits of no less than \$1,000,000 each accident, each employee and policy limit.
  - b. **Commercial General Liability** - Combined single limit of no less than \$1,000,000 each occurrence and \$2,000,000 aggregate. Coverage shall not contain any endorsement(s) excluding nor limiting Product/Completed Operations, Contractual Liability or Cross Liability.
  - c. **Commercial Automobile Liability** - Limits of no less than \$1,000,000 Combined Single Limit. Coverage shall include liability for Owned, Non-Owned and Hired automobiles. In the event Vendor does not own automobiles, Vendor agrees to maintain coverage for Hired and Non-Owned Auto Liability, which may be satisfied by way of endorsement to the Commercial General Liability policy or separate Auto Liability policy. Automobile coverage is only necessary if vehicles are used in the provision of services under this Purchase Order and/or are brought on a COR site.
  - d. **Additional Insured** - Vendor agrees to endorse the City as an Additional Insured on the Commercial General Liability. The Additional Insured shall read ‘City of Raleigh as its interest may appear’.
  - e. **Umbrella or Excess Liability** - Vendor may satisfy the minimum liability limits required above under an Umbrella or Excess Liability policy. There is no minimum Per Occurrence limit of liability under the Umbrella or Excess Liability, however, the Annual Aggregate limits shall not be less than the highest ‘Each Occurrence’ limit for required policies. Vendor agrees to endorse City of Raleigh as an ‘Additional Insured’ on the Umbrella or Excess Liability, unless the Certificate of Insurance states the Umbrella or Excess Liability provides coverage on a ‘Follow-Form’ basis.
  - f. **Professional Liability** - Limits of no less than \$1,000,000 each claim. This coverage is only necessary for professional services such as engineering, architecture or when otherwise required by the City.  
The City reserves the right to require a Certificate of Insurance meeting the minimum coverage and requirements of this section. Certificates of Insurance shall provide a minimum thirty (30) day endeavor to notify, when available, by Vendor’s insurer. If Vendor receives a non-renewal or cancellation notice from an insurance carrier affording coverage required herein, or receives notice that coverage no longer complies with the insurance requirements herein, Vendor agrees to notify the City within five (5) business days with a copy of the non-renewal or cancellation notice, or written specifics as to which coverage is no longer in compliance. The Certificate Holder address should read:  
City of Raleigh  
Post Office Box 590  
Raleigh, NC 27602-0590  
All insurance companies must be authorized to do business in North Carolina and be acceptable to the City of Raleigh’s Risk Manager.
24. **Indemnity** – To the fullest extent permitted by law, except to the extent caused by the sole negligence or willful misconduct of the City, the Vendor shall indemnify and hold and save the City, its officers, agents and employees, harmless from liability of any kind, including all claims, costs (including defense) and losses accruing or resulting to any other person, firm, or corporation furnishing or supplying work, services, materials, or supplies in connection with the performance of this Purchase Order, and from any and all claims, costs (including defense) and losses accruing or resulting to any person, firm, or corporation that may be injured or damaged by the Vendor in the performance of this Purchase Order. This representation and warranty shall survive the termination or expiration of this Purchase Order. The Vendor shall indemnify and hold and save the City, its officers, agents and employees, harmless from liability of any kind, including claims, costs (including defense) and expenses, on account of any copyrighted material, patented or unpatented invention, articles, device or appliance manufactured or used in the performance of this Purchase Order.
25. **Intellectual Property** - All intellectual property, including, but not limited to, patentable inventions, patentable plans, copyrightable works, mask works, trademarks, service marks and trade secrets invented, developed, created or discovered in performance of services under this Purchase Order shall be the property of the City. Copyright in and to any copyrightable work, including, but not limited to, copy, art, negatives, photographs, designs, text, software, or documentation created as part of the Vendor’s performance of services under this Purchase Order shall vest in the City. Works of authorship and contributions to works of authorship created by the Vendor’s performance of services under this Purchase Order are hereby agreed to be ‘works made for hire’ within the meaning of 17 U.S.C. 201.
26. **Force Majeure** - Neither party shall be deemed to be in default of its obligations hereunder if and so long as it is prevented from performing such obligations by an act of war, hostile foreign actions, nuclear explosion, earthquake, hurricane, tornado, or other catastrophic natural event or act of God. Except as otherwise provided in any environmental laws, rules, regulations or ordinances applicable to the parties and the services performed under this Purchase Order, neither party shall be deemed to be in default of its obligations hereunder if and so long as it is prevented from performing such obligations by an act of war, hostile foreign actions, nuclear explosion, earthquake, hurricane, tornado, or other catastrophic natural event or act of God. Either party to the Purchase Order must take reasonable measures and implement reasonable protections when a weather event otherwise defined as a force majeure event is forecast to be eligible to be excused from the performance otherwise required under this Purchase Order by this provision.
27. **Cancellation** - The City may terminate this Purchase Order at any time by providing written notice to the Vendor. Vendor shall cease performance immediately upon receipt of such notice. In the event of early termination, Vendor shall be entitled to receive just and equitable compensation for costs incurred prior to receipt of notice of termination and for the satisfactory work completed as of the date of termination and delivered to the City. Notwithstanding the foregoing, in no event will the total amount due to Vendor under this section exceed the total amount due Vendor under this Purchase Order.
28. **Miscellaneous** - The Vendor shall be responsible for the proper custody and care of any property furnished or purchased by the City for use in connection with the performance of this Purchase Order and will reimburse the City for the replacement value of its loss or damage. The Vendor shall be considered to be an Independent Contractor and as such shall be wholly responsible for the work to be performed and for the supervision of its employees. Nothing herein is intended or will be construed to establish any agency, partnership, or joint venture. Vendor represents that it has, or will secure at its own expense, all personnel required in performing the services under this Purchase Order. Such employees shall not be employees of or have any individual contractual relationship with the City.
29. **E-Verify** - I understand that E-Verify is the federal E-Verify program operated by the United States Department of Homeland Security and other federal agencies, or any successor or equivalent program used to verify the work authorization of newly hired employees pursuant to federal law in accordance with NCGS §64-25 et seq. I am aware of and in compliance with the requirements of E-Verify and Article 2 of Chapter 64 of the

North Carolina General Statutes. To the best of my knowledge, any subcontractors employed by me as a part of this contract are in compliance with the requirements of E-Verify and Article 2 of Chapter 64 of the North Carolina General Statutes.

30. **Iran Divestment Act Certification** – Contractor certifies that, as of the date listed below, it is not on the Final Divestment List as created by the State Treasurer pursuant to N.C.G.S. § 147-86.55, *et seq.* In compliance with the requirements of the Iran Divestment Act and N.C.G.S. § 147-86.59, Contractor shall not utilize in the performance of the contract any subcontractor that is identified on the Final Divestment List.
31. **Companies Boycotting Israel Divestment Act Certification** - Contractor certifies that it has not been designated by the North Carolina State Treasurer as a company engaged in the boycott of Israel pursuant to N.C.G.S. 147-86.81.

REMAINDER OF THIS PAGE LEFT BLANK INTENTIONALLY



## REFERENCES

Provide at least three (3) references, other than the City of Raleigh, for which your company has provided goods and services of substantially the same features and quantity to those solicited herein. References shall be checked during the evaluation period to determine that the goods provided are substantially similar to those bid herein and that the supplier's performance has been satisfactory. Information obtained will be considered in evaluation of the bids. Bidders are cautioned to provide accurate information. Misleading information presented in the references may result in a rejection of the proposal.

1. Agency or Company Name: \_\_\_\_\_

Business Address: \_\_\_\_\_

Contact Person: \_\_\_\_\_

Contact Telephone Number: \_\_\_\_\_

Contact E-Mail Address: \_\_\_\_\_

2. Agency or Company Name: \_\_\_\_\_

Business Address: \_\_\_\_\_

Contact Person: \_\_\_\_\_

Contact Telephone Number: \_\_\_\_\_

Contact E-Mail Address: \_\_\_\_\_

3. Agency or Company Name: \_\_\_\_\_

Business Address: \_\_\_\_\_

Contact Person: \_\_\_\_\_

Contact Telephone Number: \_\_\_\_\_

Contact E-Mail Address: \_\_\_\_\_