

NC STATE UNIVERSITY

Raleigh, North Carolina Request for Quotation (RFQ)

#63-DMP1142625 - Print/mail Services

For internal administrative processing, including tabulation of bids for posting to Bonfire and the State of North Carolina Electronic Vendor Portal (eVP), please provide your company's Federal Employer Identification Number or alternate identification number (e.g. Social Security Number). We HIGHLY recommend you register in order to see bid tabulations and award results. Pursuant to G.S. 132-1.10(b) this identification number shall not be released to the public. This page will be removed and shredded, or otherwise kept confidential, before the procurement file is available for public inspection.

**THIS PAGE IS TO BE COMPLETED AND INCLUDED
WITH YOUR BID. FAILURE TO DO SO MAY SUBJECT
YOUR BID TO REJECTION.**

Federal ID Number or Social Security Number:	
SUPPLIER NAME:	
DATE:	

NC STATE UNIVERSITY**PROCUREMENT & BUSINESS SERVICES**Mailing Address (USPS only): Campus Box 7212 Raleigh,
NC 27695-7212Shipping Address: Admin. I, 2721 Sullivan Drive, Suite 1100,
Raleigh, NC 27607
Phone (919) 515-2171**REQUEST FOR QUOTATION
(This is not an order)**

November 19, 2025

REQUIRED SUPPLIER INFORMATION:**Supplier Name & Address:****Authorized Rep's Name:****Title:****Email:****Phone #:****Quote # DMP1142625****Questions Due Date & Time:**
November 24, 2025, 12:00 noon**Due Date & Time:**
December 1, 2025, 5:00 PM**Authorized Representative Signature/Date:****Buyer Contact Information:**Dianne Coxson
dmpantel@ncsu.edu, (919) 513-4335**Type of Organization:**

- | | |
|--------------------------------------|--------------------------------------|
| <input type="checkbox"/> Individual | <input type="checkbox"/> Partnership |
| <input type="checkbox"/> Corporation | <input type="checkbox"/> Other: |

Requisition #: 0001142625

Using Department:

Undergrad Admissions

Indicate if other than Large Business:

- | | |
|-----------------------------------|--------------------------------------|
| <input type="checkbox"/> Disabled | <input type="checkbox"/> Minority |
| <input type="checkbox"/> Small | <input type="checkbox"/> Women-Owned |

FOB: DESTINATION - FREIGHT PREPAID
(unless otherwise indicated on RFQ)**ATTACHMENTS AND COMMENTS:**

By responding to this RFQ, supplier acknowledges acceptance of specified Terms and Conditions, which are also located:

<https://procurement.ofa.ncsu.edu/supplier-center/doing-business-with-nc-state/>

- | | |
|---|--|
| <input type="checkbox"/> General Terms & Conditions | <input type="checkbox"/> Rental Terms & Conditions |
| <input type="checkbox"/> General Terms & Conditions w/ Software | <input type="checkbox"/> Lease/Purchase Terms & Conditions |
| <input type="checkbox"/> General Terms & Conditions with EO50 | <input type="checkbox"/> Charter Bus Terms & Conditions |
| <input type="checkbox"/> Software Terms & Conditions | <input checked="" type="checkbox"/> Service Terms & Conditions |
| <input type="checkbox"/> Software as a Service Terms & Conditions | <input type="checkbox"/> Other: |

You MUST register and upload this quote as a PDF to the Bonfire Public Portal here:<https://ncsu.bonfirehub.com/opportunities/211222>**QUOTES NOT SUBMITTED ON THIS FORM ARE SUBJECT TO REJECTION.**

NC State University Request for Quotes and their awards are not subject to the North Carolina E-procurement process.

DEBARMENT CERTIFICATION: By signing the execution page, bidder certifies to the best of its knowledge and belief, that it and its principals are not presently debarred, suspended, proposed for debarment, declined ineligible or voluntary excluded from covered transactions by any Federal or State agency.

Deadline for Questions 12:00pm, 11/24/25

All Questions must be submitted in writing, by

Email to dmpantel@ncsu.edu

NO PHONE CALLS ACCEPTED.

Communication with the end user while the bid is in process is strictly prohibited.

PROJECT DESCRIPTION: Print/Mail Services - 2026 Admitted Student Packet					
#	Item Description	Quantity	Unit	Unit Cost	Extended Cost
1	Envelopes - print cost	25,000	EACH		
2	Two-Pocket Folder with Die Cut Pockets - print cost	25,000	EACH		
3	Admissions Acceptance Letter - print cost	25,000	EACH		
4	Sticker Sheet - print cost	25,000	EACH		
5	Handout A - S-Block - print cost	25,000	EACH		
6	Handout B: Belltower Handout - print cost	25,000	EACH		
7	Handout C: Pennant Handout - print cost	25,000	EACH		
8	Handout D: Ticket Handout - print	25,000	EACH		
9	Mailing #1 Early Action, Mail date: 2/6/2026	15,100	EACH		
10	Mailing #2: Transfer 1 Release, Mail date: 3/6/2026	700	EACH		
11	Mailing #3: Regular Decision + Spring Connect, Mail date: 4/3/2026	6,100	EACH		
12	Mailing #4: Transfer 2 Release, Mail date: 4/17/2026	1,900	EACH		
13	Deliver upon printing to CB 7103, 106 Peele Hall	1,200	EACH		
NC State University is exempt from sales and/or use taxes on qualifying purchases. Tax exempt # 400021.					
An ADDENDUM to this RFQ is possible. If required, any subsequent addenda must be submitted prior to the quote closing. It is the vendor's responsibility to verify that all applicable addenda are submitted prior to the quote closing date. Addenda are posted at https://evp.nc.gov/ .					

**NC STATE UNIVERSITY UNDERGRADUATE ADMISSIONS
PRINT SPECIFICATIONS**

Project Name: 2026 Admitted Student Packet

Target Print and Delivery:

Total Quantity: 25,000 copies

Printed packets will be delivered or mailed on scheduled dates below.

- Deliver upon printing: 1,200 copies of the packet (fully assembled, with the folders placed into the envelopes and sealed) to NC State Undergraduate Admissions at:

NC State University
Attn: Caroline Funkhouser
Campus Box 7103
106 Peele Hall
Raleigh, NC 27695

- Mailing #1: Early Action
 - Total quantity: 15,100
 - Mailing Date: February 6, 2026
- Mailing #2: Transfer 1 Release
 - Total quantity: 700
 - Mailing Date: March 6, 2026
- Mailing #3: Regular Decision + Spring Connect
 - Total quantity: 6,100
 - Mailing Date: April 3, 2026
- Mailing #4: Transfer 2 Release
 - Total quantity: 1,900
 - Mailing Date: April 17, 2026

Full count quantity with no shortage. Any overage must be included in the pricing submitted. NC State will only pay for the quantity ordered.

Please add all delivery charges in the quote.

Project Components

1. Envelope

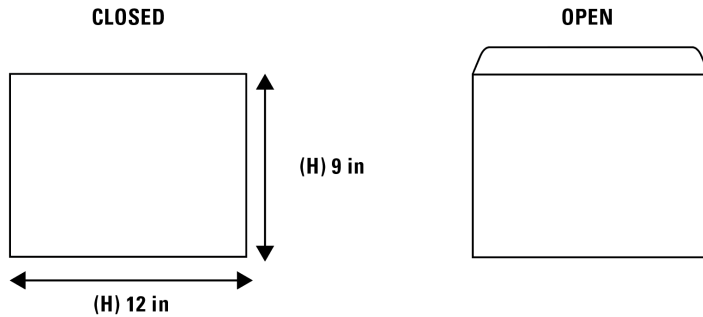

Envelope Specifications

Size and Type: (W) 9 in x (H) 12 in Open Side Booklet Envelope
 Pages: 2 pages (front and back printing)
 Paper: 28# Booklet White Wove Envelope
 Ink: 4 color process /0, no bleeds

2. Two-Pocket Folder with Die Cut Pockets

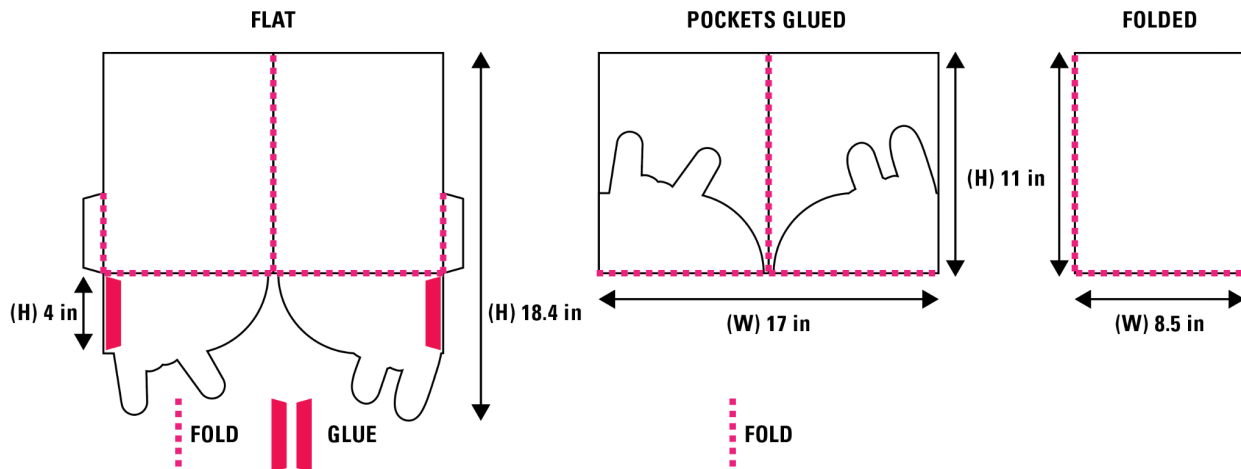

Folder Specifications

Size: (W) 8.5 in x (H) 11 in
 Paper: 100# Cover, Matte, White
 Ink: CMYK
 Registration: Tight
 Coverage: Heavy
 Bleeds: Yes, throughout
 Finishing: Trim, Score, Folds, Glue pockets
 Die Cuts: Yes

3. Admissions Acceptance Letter

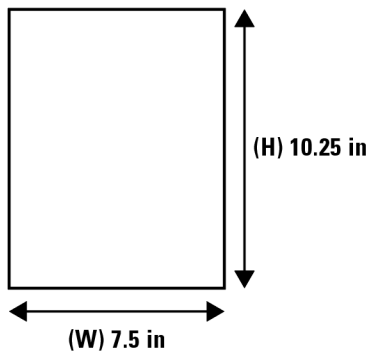

Letter Specifications

Size: (W) 7.5 in x (H) 10.25 in
 Pages: 1 page (front only)
 Paper: 70# Text, Uncoated, White
 Ink: CMYK
 Registration: Tight
 Coverage: Heavy
 Bleeds: Yes, throughout
 Finishing: Trim to size
 Die Cuts: No

4. Sticker Sheet

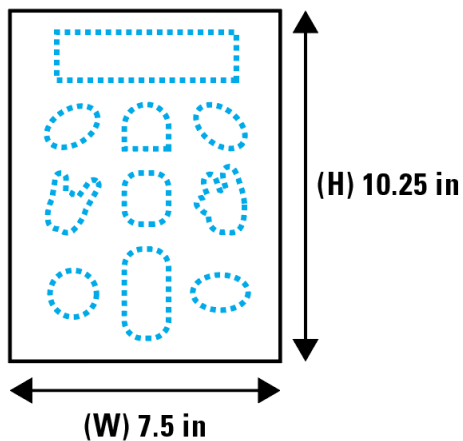

KISS CUTS
 Please note: this is a conceptual visual; final kiss cut sizes and locations will be provided with print files.

Sticker Sheet Specifications

Size: (W) 7.5 in x (H) 10.25 in
 Pages: 1 page (front only)
 Paper: Sticker paper with gloss finish
 Ink: CMYK
 Registration: Tight

Coverage: Heavy
Bleeds: Yes, throughout
Finishing: Trim sheet to size
Kiss Cuts: 10 Various Kiss Cut Stickers within the same (W) 7.5 in x (H) 10.25 in sheet

5. Four Individual Handouts with Die Cuts

Handout A: S-Block

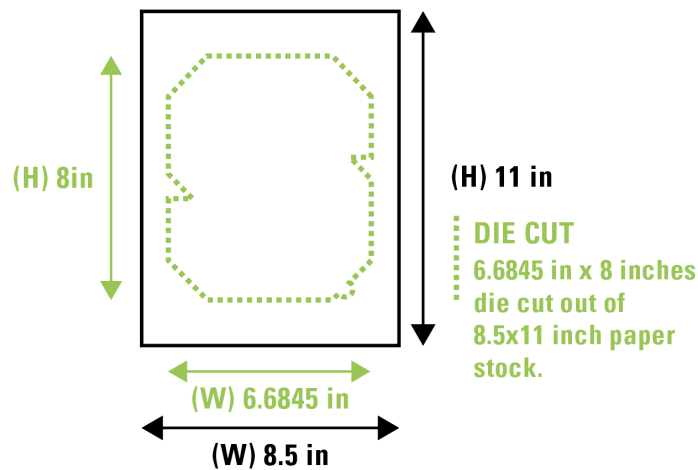

Handout A: S-Block Handout Specifications

Size: (W) 6.6845 in x (H) 8 in
Pages: 2 pages (1 front + 1 back)
Paper: 80# Matte Cover
Ink: CMYK
Registration: Tight
Coverage: Heavy
Bleeds: Yes, throughout
Die Cuts: Die cut out of (w.) 8.5 in x (h.) 11 in paper or any other suggested cost-efficiency setup.

Handout B: Belltower Handout

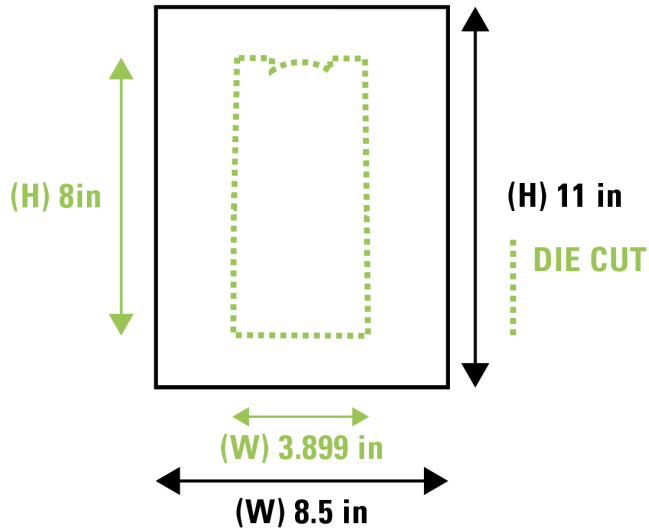

Handout B: Belltower Handout Specifications

- Size: (W) 3.899 in x (H) 8 in
- Pages: 2 pages (1 front + 1 back)
- Paper: 80# Matte Cover
- Ink: CMYK
- Registration: Tight
- Coverage: Heavy
- Bleeds: Yes, throughout
- Die Cuts: Die cut out of (w.) 8.5 in x (h.) 11 in paper or any other suggested cost-efficiency setup.

Handout C: Pennant Handout

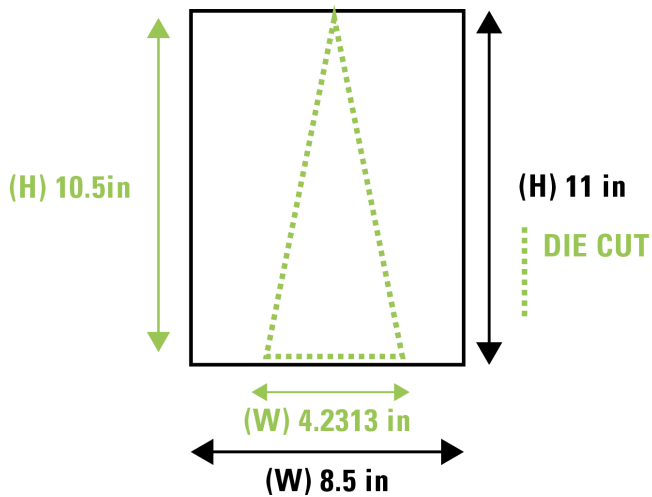

Handout C: Pennant Handout Specifications

Size: (W) 4.2313 in x (H) 10.5 in
Pages: 2 pages (1 front + 1 back)
Paper: 80# Matte Cover
Ink: CMYK
Registration: Tight
Coverage: Heavy
Bleeds: Yes, throughout
Die Cuts: Die cut out of (w.) 8.5 in x (h.) 11 in paper or any other suggested cost-efficiency setup.

Handout D: Ticket Handout

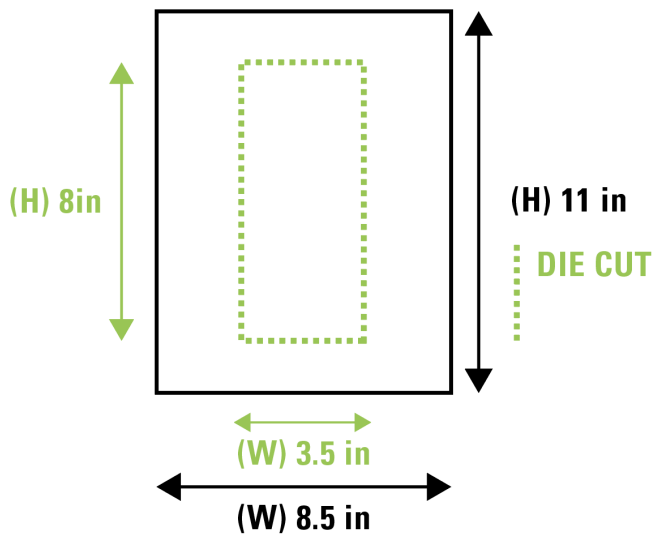

Handout D: Ticket Handout Specifications

Size: (W) 8 in x (H) 3.5 in
Pages: 2 pages (1 front + 1 back)
Paper: 80# Matte Cover
Ink: CMYK
Registration: Tight
Coverage: Heavy
Bleeds: Yes, throughout
Die Cuts: Die cut out of (w.) 8.5 in x (h.) 11 in paper or any other suggested cost-efficiency setup.

6. Kitting

Hold for mailing lists, then inkjet addresses on the envelope and **mail with the NC State University Nonprofit Permit.**

Envelope + Folder + Letter + Sticker Sheet + 4 die-cut handouts

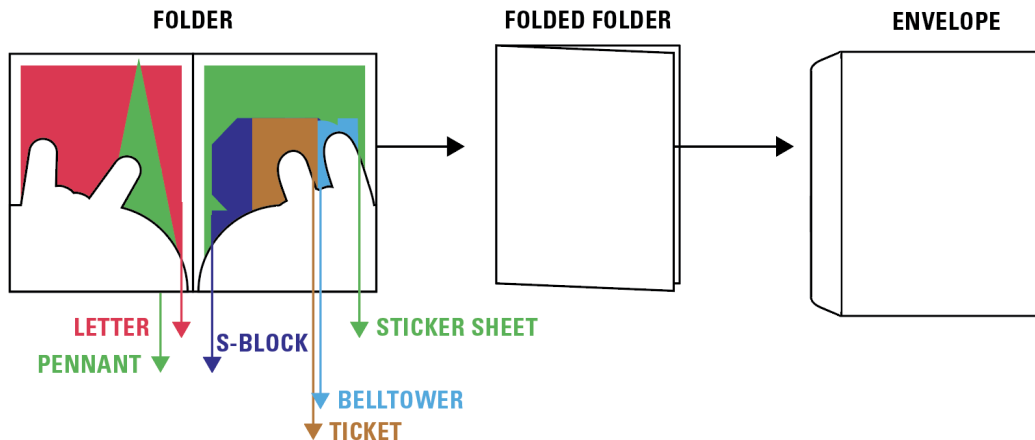

- Insert the Admissions Acceptance Letter (#3) in the left pocket of the folder (#2).
- Insert the Pennant Handout (Opt. 1 - #5) in the left pocket on the top of the letter (#3).
- Insert in the following order the Sticker Sheet (#4), the S-Block, the Ticket and the Belltower handouts (Opt. 1 - #5) in the right pocket of the folder (#2).
- Close the folder (#2) before inserting it in the envelope (#1).

General Information:

- **Press:** This project must be printed on at least a 4-color press.
- **File Format:** Print ready PDF Macintosh/PC or production files as needed (Illustrator or InDesign)
- **Software:** Adobe Creative Suite CC
- **Proofing:** High-resolution hard proof must be provided for final approval. Proof should be printed on requested paper or paper samples should be brought along with the proof. Proof delivery will be coordinated as the project progresses.
- **Delivery:** ALL DELIVERY CHARGES MUST BE INCLUDED IN QUOTE. The printer will be responsible for delivering mailers to a postal distribution center. See mail specifications.

Overages delivered to:

NC State University
Attn: CF
Campus Box 7103
106 Peele Hall
Raleigh, NC 27695

Note on packets delivered upon printing and overages: Packets should be delivered to us fully assembled, with the folder placed inside the sealed envelope.

- **Turnaround:** Printer should provide us with a production timeline based on our desired mailing dates. (See Target Print and Delivery section at the top of this document)

Can vendor meet delivery requirements? Yes _____ No _____

Mail Specifications

- **Inkjet/sort/deliver:** Printer is responsible for addressing/inkjet labeling, zip sorting and timely delivery to USPS for mailing.
 - Printer is to apply names/addresses by ink jetting directly onto the envelope per USPS specifications, using the NC State provided mailing list (Excel file, 10pt, Arial).
- **NCOA check:** Printer will build into the quote the cost of running an NCOA check and will secure this service. If the printer subs out the NCOA check to another vendor, the printer is responsible for using an established NCOA company who can be trusted not to use the addresses for other purposes.
 - The printer must provide name & address of business used for NCOA if being subbed out

- **Shipping:** All shipping costs must be included in the prices quoted herein.
 - If any materials, such as proofs, etc, are sent back to the vendor, the vendor must provide the client with their shipping account number to do so.
- **Delivery:** Split delivery as listed below. The printer will address, zip-sort and deliver to USPS to meet our requested mailing dates.
 - Mailing #1: Early Action
 - Total quantity: 15,100
 - Mailing Date: February 6, 2026
 - Mailing #2: Transfer 1 Release
 - Total quantity: 700
 - Mailing Date: March 6, 2026
 - Mailing #3: Regular Decision + Spring Connect
 - Total quantity: 6,100
 - Mailing Date: April 3, 2026
 - Mailing #4: Transfer 2 Release
 - Total quantity: 1,900
 - Mailing Date: April 17, 2026

The remaining copies should be boxed and delivered to:

NC State University
Attn: CF
Campus Box 7103
106 Peele Hall
Raleigh, NC 27695

Production: Bids from print brokers will not be considered.

References required: Vendor will supply a list of no less than two (2) references from previous print jobs that are similar in size and scope to this project. References must include name, position/title, affiliation, address, email address and telephone number.

Samples required: Vendor will supply a few samples of print products that align and showcase some of the specifications from our project components. Samples will be reviewed for their overall physical quality. See below.

Ownership: All copy, art, electronic files, negatives, photos, etc. that are required for this job remain or become the property of the University. They are to be returned to the client upon job completion, in excellent, reusable condition. Printer will be held liable for any/all damages to materials.

Requirements:

1. A printer representative must contact the customer within 24 hours after the job is awarded.
2. A printer representative must guarantee to meet the customer virtually or in-person as often as deemed necessary by the University during the job production. Such virtual visits shall include but not be limited to picking up and discussion of artwork, material and proofs. In-person meeting with the customer must be a fully qualified representative of the printer awarded the contract.
3. Printer is to supply printed samples of work with similar specifications along with the quote.
4. A blank folding dummy on the exact paper stock must be provided prior to printing.
5. Provide line item breakdown of cost for print for each printed component of the Admit Packet.
6. Provide line item breakdown of cost for mail services for each of the 4 mailings of the Admit Packet.

Vendor understands and agrees to the above requirements: Yes _____ No _____

Print samples required: Vendor must send print samples representative of the job being quoted to show quality of work. All samples must be labeled with the quotation number, Item # and vendor's name. Failure to send the samples **to be received on or before the quote due date** will be cause for rejection of the quotation. All samples are subject to the customer's approval and are considered part of the evaluation criteria for award.

Samples can be mailed or delivered to:

NC STATE UNIVERSITY – Procurement Department

Mailing Address (US Postal only): Campus Box 7212, Raleigh, NC 27695-7212

Physical Address: Admin. I, 2721 Sullivan Drive, Suite 1100, Raleigh, NC 27607

Failure to provide all samples as required will be cause for rejection of your quotation.

Past performance on NC State University printing contracts will be part of the evaluation criteria in the award of the RFQ.

1. **BID SUBMITTAL:** NC State University uses a third-party eProcurement strategic sourcing provider, Bonfire, for accepting and evaluating bids digitally. All bids must be received by the issuing agency not later than the date and time listed on the cover sheet of this bid. Bids shall be uploaded to:

<https://ncsu.bonfirehub.com/opportunities/211222>

Solicitation documents are advertised on the State of North Carolina Electronic Vendor Portal System (eVP) and [Bonfire](#). An addendum to this RFQ may be issued. If required, any subsequent addenda must be signed and submitted with the bid upload. It is the **vendor's responsibility** to verify that all applicable addenda are submitted as required.

For support or technical questions related to your submission, please contact Bonfire at support.bonfire@eunasolutions.com or visit their help forum at <https://vendorsupport.gobonfire.com/hc/en-us>

2. **BONFIRE REQUESTED DOCUMENTATION & INFORMATION:** In an effort to support the sustainability efforts of the State of North Carolina we are receiving proposals via electronic submission. Bidder is to furnish all information requested and in the spaces provided in this document. Further, if required elsewhere in this bid, each bidder must submit with their bid sketches, descriptive literature and/or complete specifications covering the products offered. Reference to literature submitted with a previous bid will not satisfy this provision. Bids which do not comply with these requirements will be subject to rejection.

Please note the type and number of files allowed. The maximum upload file size is 1000 MB. Uploading large documents may take significant time, depending on the size of the file(s) and your Internet connection speed. Please do not embed any documents within your uploaded files, as they will not be accessible or evaluated. Minimum system requirements: Microsoft Edge, Google Chrome, or Mozilla Firefox. Javascript must be enabled. Browser cookies must be enabled.

Name	File Type	# of Files	Requirement
Completed NC State University Solicitation Document	PDF	1	Required

All documents required to complete your submission must be downloaded from the supporting documentation and/or requested information sections of Bonfire. You will receive an email confirmation receipt with a unique confirmation number once you finalize your submission. Each item of Requested Information will only be visible to NC State University after the Closing Time.

INSTRUCTIONS TO BIDDERS

1. **READ, REVIEW AND COMPLY:** It shall be the bidder's responsibility to read this entire document, review all enclosures and attachments, and comply with all requirements specified herein.
2. **NOTICE TO BIDDERS:** All bids are subject to the provisions of the Instructions to Bidders, special terms and conditions specific to this Request for Quotation, the specifications, and the North Carolina State University General Contract Terms and Conditions.
The University objects to and will not evaluate or consider any additional terms and conditions submitted with a bidder response. This applies to any language appearing in or attached to the document as part of the bidder's response. **DO NOT ATTACH ANY ADDITIONAL TERMS AND CONDITIONS.**
By execution and delivery of this document, the bidder agrees that any additional terms and conditions, whether submitted purposely or inadvertently, shall have no force or effect.
3. **DEFINITIONS:**
 - **BIDDER:** Company, firm, corporation, partnership, individual, etc., submitting a response to an Invitation for Bids.
 - **TERM CONTRACT:** A contract generally intended to cover all normal requirements for a commodity for a specified period of time based on estimated quantities only.
 - **STATEWIDE TERM CONTRACT:** A Term Contract for all agencies, unless exempted by statute, rule, or special term and condition specific to this bid.
 - **AGENCY SPECIFIC TERM CONTRACT:** A Term Contract for a specific agency.
 - **OPEN MARKET CONTRACT:** A contract for the purchase of a commodity not covered by a term contract.
4. **EXECUTION:** Failure to sign under EXECUTION section will render bid invalid.
5. **ORDER OF PRECEDENCE:** In cases of conflict between specific provisions in this bid, the order of precedence shall be (1) special terms and conditions specific to this bid, (2) specifications, (3) North Carolina State University General Contract Terms and Conditions, and (4) Instructions to Bidders.
6. **TIME FOR CONSIDERATION:** Unless otherwise indicated on the first page of this document, bidder's offer shall be valid for 45 days from the date of bid opening. Preference may be given to bids allowing not less than 45 days for consideration and acceptance.
7. **PROMPT PAYMENT DISCOUNTS:** Bidders are urged to compute all discounts into the price offered. If a prompt payment discount is offered, it will not be considered in the award of the contract except as a factor to aid in resolving cases of identical prices.
8. **SPECIFICATIONS:** Any deviation from specifications indicated herein must be clearly pointed out; otherwise, it will be considered that items offered are in strict compliance with these specifications, and bidder will be held responsible therefore. Deviations shall be explained in detail. **The bidder shall not construe this paragraph as inviting deviation or implying that any deviation will be acceptable.**
9. **INFORMATION AND DESCRIPTIVE LITERATURE:** Bidder is to furnish all information requested and in the spaces provided in this document. Further, if required elsewhere in this bid, each bidder must submit with their bid sketches, descriptive literature and/or complete specifications covering the products offered. Reference to literature submitted with a previous bid will not satisfy this provision. Bids which do not comply with these requirements will be subject to rejection.
10. **RECYCLING AND SOURCE REDUCTION:** It is the policy of this State to encourage and promote the purchase of products with recycled content to the extent economically practicable, and to purchase items which are reusable, refillable, repairable, more durable, and less toxic to the extent that the purchase or use is practicable and cost-effective. We also encourage and promote using minimal packaging and the use of recycled/recyclable products in the packaging of commodities purchased. However, no sacrifice in quality of packaging will be acceptable. The company remains responsible for providing packaging that will protect the commodity and contain it for its intended use. Companies are strongly urged to bring to the attention of purchasers those products or packaging they offer which have recycled content and that are recyclable.
11. **CLARIFICATIONS/INTERPRETATIONS:** Any and all questions regarding this document must be addressed to the purchaser named on the cover sheet of this document. Do not contact the user directly. Any and all revisions to this document shall be made only by written addendum. The bidder is cautioned that the requirements of this bid can be altered only by written addendum and that verbal communications from whatever source are of no effect.
12. **ACCEPTANCE AND REJECTION:** The University reserves the right to reject any and all bids, to waive any informality in bids and, unless otherwise specified by the bidder, to accept any item in the bid. If either a unit price or extended price is obviously in error and the other is obviously correct, the incorrect price will be disregarded.

13. **REFERENCES:** The University reserves the right to require a list of users of the exact item offered. The quote evaluators may contact these users to determine acceptability of the bid. Such information may be considered in the evaluation of the bid.

14. **TAXES:**

- **FEDERAL:** All agencies participating in this contract are exempt from Federal Taxes, such as excise and transportation. Exemption is claimed under Registry No. 56-70-0047K as provide by Chapter 32 of the Internal Revenue Code.
- **OTHER:** Prices offered are not to include any personal property taxes, nor any sales or use tax (or fees) unless required by the North Carolina Department of Revenue.

15. **AWARD OF CONTRACT:** As directed by statute, qualified bids will be evaluated and acceptance may be made of the lowest and best bid most advantageous to the University as determined upon consideration of such factors as: prices offered; the quality of the articles offered; the general reputation and performance capabilities of the bidders; the substantial conformity with the specifications and other conditions set forth in the bid; the suitability of the articles for the intended use; the related services needed; the date or dates of delivery and performance; and such other factors deemed by the University to be pertinent or peculiar to the purchase in question. Unless otherwise specified by the University or the bidder, the University reserves the right to accept any item or group of items on a multi-item bid.

The University reserves the right to make partial, progressive or multiple awards: where it is advantageous to award separately by items; or where more than one supplier is needed to provide the contemplated requirements as to quantity, quality, delivery, service, geographical areas; other factors deemed by the University to be pertinent or peculiar to the purchase in question.

16. **HISTORICALLY UNDERUTILIZED BUSINESSES:** Pursuant to General Statute 143-48 and Executive Order #150, the University invites and encourages participation in this procurement process by businesses owned by minorities, women, disabled, disabled business enterprises and non-profit work centers for the blind and severely disabled.

17. **CONFIDENTIAL INFORMATION:** Contractors should give specific attention to the identification of those portions of their proposals that they deem to be trade secrets and provide any justification why such materials, upon request, should not be disclosed. However, if the information you deem confidential is NOT a trade secret then the information will be released. The University may only keep information confidential to the extent permitted by NCAC T01:05B.1501 and G.S. 132-1.3.

Contractors shall clearly identify each and every section that is deemed to be confidential, proprietary or a trade secret (it is **NOT** sufficient to preface your proposal with a proprietary statement, or to use a page header or footer that arbitrarily marks all pages as confidential). Any individual section of the proposal that is not labeled as confidential with an accompanying statement concerning the rationale for its claimed confidentiality shall be considered public information.

CONFIDENTIALITY OF BIDS: In submitting its quote, the Bidder agrees not to discuss or otherwise reveal the contents of the quotes to any source outside of the University, until after the award of the contract. All Bidders are advised that they are not to have any communications with the using department during the evaluation of the bids (i.e., after the opening of the bids and before the award of the contract), unless the University's purchaser contacts the Bidder(s) for purposes of seeking clarification. A Bidder shall not: transmit to the using department any information commenting on the ability or qualifications of any other Bidder to provide the advertised good, equipment, commodity; defects, errors and/or omissions in any other Bidder's quote and/or prices at any time during the procurement process; and/or engage in any other communication or conduct attempting to influence the evaluation and/or award of the contract that is the subject of this RFQ. Bidders not in compliance with this provision may be disqualified, at the option of the University, from the contract award. Only those communications authorized by this RFQ are permitted.

18. **SAMPLES:** Sample of items, when required, must be furnished as stipulated herein, free of expense, and if not destroyed will, upon request be returned at the bidder's expense. Request for the return of samples must be made within 10 days following date of bid opening. Otherwise the samples will become the University's property. Each individual sample must be labeled with the bidder's name, bid number, and item number. A sample on which an award is made, will be retained until the contract is completed, and then returned, if requested, as specified above.

19. **PROTEST PROCEDURES:** A party wanting to protest a contract award pursuant to this solicitation must submit a written request to the Director of Purchasing, North Carolina State University, Purchasing Department, Campus Box 7212, Raleigh, NC 27695-7212. This request must be received in the University Purchasing Department within thirty (30) consecutive calendar days from the date of the contract award, and must contain specific sound reasons and any supporting documentation for the protest. NOTE: Contract award notices are sent **only** to those actually awarded contracts, and not to every person or firm responding to this solicitation. Offerors may call the purchaser listed on the first page of this document to obtain a verbal status of contract award. All protests will be handled pursuant to the North Carolina Administrative Code, Title 1, Department of Administration, Chapter 5, Purchase and Contract, Section 5B.1519.

20. **MISCELLANEOUS:** Masculine pronouns shall be read to include feminine pronouns, and the singular of any word or phrase shall be read to include the plural and vice versa.

21. **RECIPROCAL PREFERENCE:** G.S. 143-59 establishes a reciprocal preference law to discourage other states from applying in-state preferences against North Carolina’s resident bidders. The “Principal Place of Business” is defined as the principal place from which the trade or business of the bidder is directed or managed.
22. **ENTERPRISE-LEVEL IT SYSTEMS OR TECHNOLOGIES:** The University is committed to promote and integrate universal IT accessibility in the delivery of its resources and to develop innovative solutions to accessibility challenges for students, faculty and staff. Vendors must:
- a. Assure all features, components and sub-systems of the software or IT System contained on this RFQ **fully comply** with Section 508 of the Rehabilitation Act of 1973, as amended (29 U.S.C. 794d), (<http://www.section508.gov>);
OR
Detail why any feature, component or sub-system contained in this RFQ does not **fully comply** with Section 508, and the way in which the proposed product is out of compliance;
 - b. If the Voluntary Product Accessibility Templates (VPAT) (<http://www.access-star.org/ITI-VPAT-v1.2.html>) are used, they must include compliance checklists for:
 - 1. Technical Standards,
 - 2. Function and Performance Criteria
 - 3. Documentation and Support
 - c. The product offered in response to this RFQ is subject to an accessibility evaluation by the University.

NORTH CAROLINA STATE UNIVERSITY
GENERAL CONTRACT TERMS AND CONDITIONS
(Contractual and Consultant Services)

1. **GOVERNING LAW:** This contract is made under and shall be governed and construed in accordance with the laws of the State of North Carolina.
2. **SITUS:** The place of this contract, its situs and forum, shall be Wake County, North Carolina, where all matters, whether sounding in contract or tort, relating to its validity, construction, interpretation and enforcement shall be determined.
3. **INDEPENDENT CONTRACTOR:** The Contractor shall be considered to be an independent contractor and as such shall be wholly responsible for the work to be performed and for the supervision of its employees. The Contractor represents that it has, or will secure at its own expense, all personnel required in performing the services under this agreement. Such employees shall not be employees of, or have any individual contractual relationship with the Agency.
4. **KEY PERSONNEL:** The Contractor shall not substitute key personnel assigned to the performance of this contract without prior written approval by the University's Contract Administrator. The individuals designated as key personnel for purposes of this contract are those specified in the Contractor's proposal.
5. **BACKGROUND CHECKS:** The Supplier shall, at no additional cost to the University, secure appropriate background checks for all employees to be assigned to any resulting contract. These background checks shall include criminal conviction and sex offender checks at a minimum. These background checks shall be maintained by the supplier and are subject to audit by appropriate University or state officials at any time during and for five (5) years after the contract end date. NC State may withhold consent for any of Supplier's employees to be placed on a University assignment at its sole discretion. The Supplier shall immediately (same day as notification) remove any employee from NC State property that the University deems unfit for any reason.
6. **SUBCONTRACTING:** Work proposed to be performed under this contract by the Contractor or its employees shall not be subcontracted without prior written approval of the University's Contract Administrator. Acceptance of an offeror's proposal shall include any subcontractor(s) specified therein.
7. **PERFORMANCE AND DEFAULT:** If, through any cause, the Contractor shall fail to fulfill in timely and proper manner the obligations under this agreement, the University shall thereupon have the right to terminate this contract by giving written notice to the Contractor and specifying the effective date thereof. In that event, all finished or unfinished deliverable items under this contract prepared by the Contractor shall, at the option of the University, become its property, and the Contractor shall be entitled to receive just and equitable compensation for any satisfactory work completed on such materials. Notwithstanding, the Contractor shall not be relieved of liability to the University for damages sustained by the University by virtue of any breach of this agreement, and the University may withhold any payment due the Contractor for the purpose of setoff until such time as the exact amount of damages due the University from such breach can be determined.

In case of default by the Contractor, the University may procure the services from other sources and hold the Contractor responsible for any excess cost occasioned thereby. The University reserves the right to require performance bond or other acceptable alternative guarantees from successful offeror without expense to the University.

In addition, in the event of default by the Contractor under this contract, the State may immediately cease doing business with the Contractor, immediately terminate for cause all existing contracts the State has with the Contractor, and de-bar the Contractor from doing future business with the State.

Upon the Contractor filing a petition for bankruptcy or the entering of a judgment of bankruptcy by or against the Contractor, the University may immediately terminate, for cause, this contract and all other existing contracts the Contractor has with the University.

Neither party shall be deemed to be in default of its obligations hereunder if and so long as it is prevented from performing such obligations by any act of war, hostile foreign action, nuclear explosion, riot, strikes, civil insurrection, earthquake, hurricane, tornado, or other catastrophic natural event or act of God.

8. **FORCE MAJEURE:** Neither party shall be deemed to be in default of its obligations hereunder if and so long as it is prevented from performing such obligations by an act of war, hostile foreign action, nuclear explosion, earthquake, hurricane, tornado, or other catastrophic natural event or act of God.

9. **TERMINATION:** The University may terminate this agreement at any time by providing written notice to the contractor at least thirty (30) days before the effective date of the termination. In that event, all finished or unfinished deliverable items prepared by the Contractor under this contract shall, at the option of the University, become its property. If the contract is terminated by the University as provided herein, the Contractor shall be paid for services satisfactorily completed, less payment or compensation previously made. All promises, requirements, terms, conditions, provisions, representations, guarantees, and warranties contained herein shall survive the contract expiration or termination date unless specifically provided otherwise herein, or unless superseded by applicable Federal or State statutes of limitations.
10. **PAYMENT TERMS:** Payment terms are Net not later than 30 days after receipt of correct invoice or acceptance of goods, whichever is later. The University is responsible for all payments to the contractor under the contract. Payment may be made by procurement card and it shall be accepted by the contractor for payment if the contractor accepts that card (Visa, Mastercard, etc.) from other customers. If payment is made by procurement card, then payment may be processed immediately by the contractor.
11. **AVAILABILITY OF FUNDS:** Any and all payments to the Contractor are dependent upon and subject to the availability of funds to the University for the purpose set forth in this agreement.
12. **CONFIDENTIALITY:** Any information, data, instruments, documents, studies or reports given to or prepared or assembled by the Contractor under this agreement shall be kept as confidential and not divulged or made available to any individual or organization without the prior written approval of the Agency.
13. **CARE OF PROPERTY:** The Contractor agrees that it shall be responsible for the proper custody and care of any property furnished it for use in connection with the performance of this contract or purchased by it for this contract and will reimburse the State for loss of damage of such property.
14. **COPYRIGHT:** No deliverable items produced in whole or in part under this agreement shall be the subject of an application for copyright by or on behalf of the Contractor.

Copyright in and to any copyrightable work, including, but not limited to, copy, art, negatives, photographs, designs, text, software, or documentation created as part of Contractor's provision of Services shall vest in NC State. Works of authorship and contributions to works of authorship created by Contractor in connection with its provision of Services are hereby agreed to be "works made for hire" within the meaning of 17 U.S.C. 201. However, if NC State is not able to obtain copyright ownership under the statutory provisions for "works made for hire," then Contractor hereby assigns to NC State all right, title, and interest in such works and contributions.

Contractor agrees to provide NC State with any and all reasonable assistance which NC State may require to file patent applications, to obtain copyright registrations, or to perfect its title in any such inventions or works, including the execution of any documents submitted by NC State.

Contractor warrants that its Services do not infringe the copyright of others and agrees to release, discharge and hold harmless NC State, its employees and agents, all persons acting under its authority, and those for whom it is acting, from all claims, causes of action and liability of any kind, in law or equity, based upon or arising out of the Services or this Agreement including, without limitation, claims of libel, slander, invasion of privacy, right of publicity, defamation, trademark infringement, and copyright infringement.

No deliverable items produced in whole or in part under this agreement shall be the subject of an application for copyright by or on behalf of the Contractor.

15. **ACCESS TO PERSONS AND RECORDS:** The State or NC State auditor, or the Joint Commission on Governmental Operations and legislative employees whose primary responsibility is to provide professional or administrative services to the Commission, may audit the records of contractor during and after the term of this Agreement to verify accounts and data affecting fees or performance in accordance with North Carolina General Statutes §143-49(9) and §147-64.7 and Session Law 2023-134.
16. **ASSIGNMENT:** No assignment of the Contractor's obligations nor the Contractor's right to receive payment hereunder shall be permitted. However, upon written request approved by the issuing purchasing authority, the University may:
 - a. Forward the contractor's payment check(s) directly to any person or entity designated by the Contractor, or
 - b. Include any person or entity designated by Contractor as a joint payee on the Contractor's payment check(s).In no event shall such approval and action obligate the University to anyone other than the Contractor and the Contractor shall remain responsible for fulfillment of all contract obligations.

17. **COMPLIANCE WITH LAWS:** The Contractor shall comply with all laws, ordinances, codes, rules, regulations, and licensing requirements that are applicable to the conduct of its business, including those of federal, state, and local agencies having jurisdiction and/or authority.
18. **AFFIRMATIVE ACTION:** The Contractor shall take affirmative action in complying with all Federal and State requirements concerning fair employment and employment of people with disabilities, and concerning the treatment of all employees without regard to discrimination by reason of race, color, religion, sex, national origin, or disability.
19. **INSURANCE:** During the term of the contract, the contractor at its sole cost and expense shall provide commercial insurance of such type and with such terms and limits as may be reasonably associated with the contract. As a minimum, the contractor shall provide and maintain the following coverage and limits:
 - a. Worker's Compensation - The contractor shall provide and maintain Worker's Compensation Insurance, as required by the laws of North Carolina, as well as employer's liability coverage with minimum limits of \$500,000.00, covering all of Contractor's employees who are engaged in any work under the contract. If any work is subcontracted, the contractor shall require the subcontractor to provide the same coverage for any of its employees engaged in any work under the contract.
 - b. Commercial General Liability - General Liability Coverage on a Comprehensive Broad Form on an occurrence basis in the minimum amount of \$1,000,000.00 Combined Single Limit. (Defense cost shall be in excess of the limit of liability.)
 - c. Automobile - Automobile Liability Insurance, to include liability coverage, covering all owned, hired and non-owned vehicles, used in connection with the contract. The minimum combined single limit, on a per occurrence basis shall be \$1,000,000.00 bodily injury and property damage; \$1,000,000.00 uninsured/under insured motorist; and \$1,000.00 medical payment.

Providing and maintaining adequate insurance coverage is a material obligation of the contractor and is of the essence of this contract. All such insurance shall meet all laws of the State of North Carolina. Such insurance coverage shall be obtained from companies that are authorized to provide such coverage and that are authorized by the Commissioner of Insurance to do business in North Carolina. The contractor shall at all times comply with the terms of such insurance policies, and all requirements of the insurer under any such insurance policies, except as they may conflict with existing North Carolina laws or this contract. The limits of coverage under each insurance policy maintained by the contractor shall not be interpreted as limiting the contractor's liability and obligations under the contract.

20. **ADVERTISING:** Contractor shall not use the existence of this contract or the name of the State of North Carolina or North Carolina State University as part of any advertising.
21. **ENTIRE AGREEMENT:** This contract and any documents incorporated specifically by reference represent the entire agreement between the parties and supersede all prior oral or written statements or agreements. This Request for Quote, any addenda thereto, and the offeror's response are incorporated herein by reference as though set forth verbatim.

All promises, requirements, terms, conditions, provisions, representations, guarantees, and warranties contained herein shall survive the contract expiration or termination date unless specifically provided otherwise herein, or unless superseded by applicable Federal or State statutes of limitation.
22. **AMENDMENTS:** This contract may be amended only by written amendments duly executed by the University and the Contractor.
23. **TAXES:** G.S. 143-59.1 bars the Secretary of Administration from entering into contracts with vendors if the vendor or its affiliates meet one of the conditions of G. S. 105-164.8(b) and refuse to collect use tax on sales of tangible personal property to purchasers in North Carolina. Conditions under G. S. 105-164.8(b) include: (1) Maintenance of a retail establishment or office, (2) Presence of representatives in the State that solicit sales or transact business on behalf of the vendor and (3) Systematic exploitation of the market by media-assisted, media-facilitated, or media-solicited means. By execution of the bid document the vendor certifies that it and all of its affiliates, (if it has affiliates), collect(s) the appropriate taxes.
24. **GENERAL INDEMNITY:** The contractor shall hold and save the University, its officers, agents, and employees, harmless from liability of any kind, including all claims and losses accruing or resulting to any other person, firm, or corporation furnishing or supplying work, services, materials, or supplies in connection with the performance of this contract, and from any and all claims and losses accruing or resulting to any person, firm, or corporation that may be injured or damaged by the contractor in the performance of this contract and that are attributable to the negligence or intentionally tortious acts of the contractor provided that the contractor is notified in writing within 30 days that the State has knowledge of such claims. The contractor represents and warrants that it shall make no claim of any kind or nature against the University's agents who are

involved in the delivery or processing of contractor goods to the University. The representation and warranty in the preceding sentence shall survive the termination or expiration of this contract.

25. **OUTSOURCING:** Any vendor or subcontractor providing call or contact center services to the University or State of North Carolina shall disclose to inbound callers the location from which the call or contact center services are being provided.

If, after award of a contract, the contractor wishes to outsource any portion of the work to a location outside the United States, prior written approval must be obtained from the University agent responsible for the contract.

Vendor must give notice to the University of any relocation of the vendor, employees of the vendor, subcontractors of the vendor, or other persons performing services under a state contract outside of the United States.

26. **DEBARMENT CERTIFICATION:** Offeror certifies to the best of its knowledge and belief, that it nor any of its principals a) are not presently debarred, suspended, proposed for debarment, or declared ineligible for the award of contract by any Federal agency; b) have not within a three year period preceding this award been convicted of or had a civil judgment rendered against them for: commission of a fraud or a criminal offense in connection with obtaining, attempting to obtain, or performing a public (Federal, state or local) contract or subcontract; violation of Federal or state antitrust statutes relating to this submission of offers; or commission of embezzlement, theft, forgery, bribery, falsifications or destruction of records, making false statements, or receiving stolen property; and c) are not presently indicted for, or otherwise criminally or civilly charged by a government entity with, commission of any of these offenses enumerated herein. The offer certifies that they have not, within a three year period preceding this offer, had one or more contracts terminated for default by any federal agency.

“Principals” for the purpose of this certification, means officers; directors; owners; partners; and persons having primary management or supervisory responsibilities within a business entity (e.g., general manager; plant manager; head of a subsidiary, division, or business segments, and similar positions.)

This certification concerns a matter within the jurisdiction of an agency of the United States and the making of a false, fictitious, or fraudulent certification may render the maker subject to prosecution. Certification of this provision is a material representation of fact upon which reliance was placed when making an award. If it is later determined that the Offeror knowingly rendered an erroneous certification, in addition to other remedies available to the University, the University may terminate this agreement for default.

Offeror hereby certifies these conditions and does so by signing the execution page of this quote document.

27. **PERSONAL IDENTIFIERS:** If the University provides the Contractor with personal identifiers as listed in North Carolina General Statute 131-1.10 or any other legally confidential information, Contractor hereby certifies that, pursuant to NCGS 132-1.10, collection of social security number information or other legally confidential information from University is necessary for the performance of Contractor duties and responsibilities on behalf of the University. Contractor further certifies that it shall maintain the confidential and exempt status of any such social security number information, as required by subsection (c)(1) of the statute.

28. **IRAN DIVESTMENT ACT -CERTIFICATION AND ONGOING OBLIGATIONS:** The NC General Assembly recently enacted the Iran Divestment Act (S.L. 2015-118). This requirement applies to all units of State government and to all political subdivisions of the State. The Iran Divestment Act List is a list published by the North Carolina Department of State Treasurer pursuant to the requirements of this Act that identifies persons engaged in investment activities in Iran. Currently, the list is available at the following URL: <https://www.nctreasurer.com/inside-the-department/OpenGovernment/Pages/Iran-Divestment-Act-Resources.aspx> .

By accepting an order from the University, the Contractor certifies that, as of the date of acceptance, it is not on the then-current version of the Iran Divestment Act List. Contractor agrees to not contract with any person to perform a part of the contractual work, if, at the time the Contractor enters into a subcontract, that person is on the then-current version of the Iran Divestment Act List. Contractor further agrees to notify the Procurement Specialist if, at any time during the contract term, including any renewal terms, it is added to the Iran Divestment Act List.

REFERENCES

OFFERORS MUST PROVIDE THREE (3) REFERENCES FOR WHOM THEY HAVE PERFORMED SIMILAR WORK IN THE PAST THREE (3) YEARS.

#1	Company Name:	
	Contact Name:	
	Email Address:	
	Telephone Number:	

#2	Company Name:	
	Contact Name:	
	Email Address:	
	Telephone Number:	

#3	Company Name:	
	Contact Name:	
	Email Address:	
	Telephone Number:	

THIS PAGE MUST BE COMPLETED AND SUBMITTED AS A PART OF YOUR QUOTATION.

