



Request for Proposals No. 2026-044 **Aeration Tank Cleaning**

Due Date: March 17, 2026
Time: 11:00 AM EST
Receipt Location: Electronic Submission (Refer to Section 2)
Union County Procurement and Contract
Management Department
(Note: Follow the submittal instructions in Section 2.2
to electronically upload a proposal package.)

Non-Mandatory Pre-Proposal Conference and Site Visit. February 18, 2026. For the
time and location, Refer to page 3 for details.

Procurement Contact:

Juan Rodriguez-Cruz
Procurement Specialist
704.283.3519
Juan.Rodriguez-Cruz@unioncountync.gov

1	NOTICE OF ADVERTISEMENT	3
2	SUBMITTAL DETAILS	5
2.1	PROPOSAL SUBMISSION DEADLINE AND DELIVERY ADDRESS.....	5
2.2	PROPOSAL SUBMISSION REQUIREMENTS	5
2.3	PRE-PROPOSAL CONFERENCE AND SITE VISIT	5
2.4	PROPOSAL QUESTIONS.....	5
2.5	PROPOSAL ADDENDUM	6
2.6	COMMUNICATION	6
3	PURPOSE.....	6
3.1	COUNTY.....	6
3.2	INTRODUCTION	6
4	SCOPE OF SERVICES	6
4.1	SCOPE OF WORK SUMMARY	6
4.2	SAFETY	8
4.3	SPECIAL REQUIREMENTS	8
5	DETAILED SUBMITTAL REQUIREMENTS AND INSTRUCTIONS	9
5.1	TERMS OF SUBMISSION	9
5.2	DUPLICATE PROPOSALS	9
5.3	PROPOSAL FORMAT	10
5.3.1	<i>SECTION A – COVER LETTER</i>	<i>11</i>
5.3.2	<i>SECTION B – COMPANY BACKGROUND AND EXPERIENCE</i>	<i>11</i>
5.3.3	<i>SECTION C – PROJECT TEAM.....</i>	<i>11</i>
5.3.4	<i>SECTION D - METHODOLOGY AND IMPEMETATION PLAN</i>	<i>12</i>
5.3.5	<i>SECTION F – REFERENCES.....</i>	<i>12</i>
5.3.6	<i>SECTION G – PRICE FORM.....</i>	<i>12</i>
5.3.7	<i>SECTION H – REQUIRED FORMS</i>	<i>12</i>
6	EVALUATION CRITERIA AND SELECTION PROCESS	13
6.1	SELECTION PARTICIPANTS	13
6.2	FINANCIAL INFORMATION.....	13
6.3	EVALUATION SELECTION PROCESS	13
6.4	AWARD PROCEDURE	14
6.5	CONFLICT CERTIFICATION	15
7	GENERAL CONDITIONS AND REQUIREMENTS.....	15
7.1	TERMS AND CONDITIONS	15
7.2	CONTRACTUAL OBLIGATIONS	16
7.3	SUB-CONTRACTOR/PARTNER DISCLOSURE	16
7.4	EXCEPTION TO THE PROPOSAL.....	16
7.5	MODIFICATION OR WITHDRAWAL OF PROPOSAL.....	16
7.6	EQUAL EMPLOYMENT OPPORTUNITY	16
7.7	MINORITY BUSINESSES OR DISADVANTAGED BUSINESSES	16
7.8	LICENSES	17
7.9	E-VERIFY.....	17

7.10	DRUG-FREE WORKPLACE	17
7.11	INSURANCE.....	17
7.12	INDEMNIFICATION	20
8	APPENDIX A – PRICE FORM.....	21
9	APPENDIX B – PROPOSAL SUBMISSION	22
10	APPENDIX C – ADDENDUM AND ANTI-COLLUSION.....	23
11	APPENDIX D – AERATION TANK DRAWINGS	24
12	APPENDIX E – SAMPLE VENDOR PAYMENT NOTIFICATION.....	25
13	APPENDIX F – TEMPLATE CONTRACT.....	26
14	APPENDIX G – STORMWATER MAP	27

1 NOTICE OF ADVERTISEMENT

Union County, North Carolina Request for Proposals No. 2026-044 Aeration Tank Cleaning

Electronic proposals will be received by the Union County's Procurement Department via electronic portal only, until **11:00 AM EST on March 17, 2026**. Late submittals will not be accepted.

Union County, North Carolina, through Union County Water, is soliciting proposals from experienced and qualified firms to provide Aeration Tank Cleaning Services.

Copies of the solicitation may be obtained from the locations listed below:

1. Download the Proposal Documents from the Union County website:
<https://www.unioncountync.gov/departments/bids-procurement/current-bids>
2. Download the Solicitation Documents from the State of North Carolina Electronic Vendor Portal: <https://evp.nc.gov> (Search County of Union – Filter Solicitation Status Open).

A Non-Mandatory Pre-proposal and Site Visit Meeting: This is a non-mandatory meeting that will take place on **February 18, 2026 at 10:00 AM** at the Twelve Mile Creek WRF, 8299 Kensington Dr. Waxhaw NC 28173. Representatives from Union County Water will be on-hand to give a brief overview of the project and to answer questions. Attendance at this meeting is strongly encouraged.

All questions about the meaning or intent of the Proposal Documents are to be submitted in writing to the Procurement contact person listed on the cover page (Juan.Rodriguez-Cruz@unioncountync.gov). The deadline for questions is on **February 25, at 5:00 PM EST**.

Union County reserves the right to reject any or all proposals, to waive technicalities and to make such selection deemed in its best interest.

Union County reserves the right to award to multiple vendors.

Offerors are required to comply with the non-collusion requirements set forth in the Solicitation Documents.

Union County encourages good faith effort outreach to Minority Businesses (HUB Certified) and Small Businesses.

2 SUBMITTAL DETAILS

2.1 PROPOSAL SUBMISSION DEADLINE AND DELIVERY ADDRESS

All Proposal Submittals are to be received by the Union County Procurement Department no later than **11:00 AM EST on March 17, 2026**, per the instructions below. Any submittals received after this date and time shall be rejected without exception.

2.2 PROPOSAL SUBMISSION REQUIREMENTS

The proposal must be submitted electronically using the following link: <https://lfportal.unioncountync.gov/Forms/procurementsubmit>. Select the Solicitation drop down arrow and choose this RFP from the list. Complete the form, upload your proposal, and select submit. An email will be sent to the address listed on the form as your confirmation of receipt.

The proposal package **must be signed** by a person who is authorized to bind the proposing Company. Instructions for preparing the proposal are provided herein.

Paper submissions will not be accepted.

Submissions e-mailed directly to the Procurement Contact will not be accepted.

There is no expressed or implied obligation for Union County to reimburse Offerors for any expenses incurred in preparing proposals in response to this request.

Union County reserves the right to:

- Reject any or all proposals, to waive technicalities and to make such selection deemed in its best interest;
- Cancel this solicitation; and
- Award to multiple vendors.

2.3 PRE-PROPOSAL CONFERENCE AND SITE VISIT

A Non-Mandatory Pre-Proposal Conference will be held on **February 18, at 10:00 AM** at the Twelve Mile Creek WRF, 8299 Kensington Dr. Waxhaw NC 28173. Union County Water staff and a Union County Procurement representative will be present to give a brief overview of the project and give access to the facility.

2.4 PROPOSAL QUESTIONS

Proposal questions will be due on or before **February 25, 2026 at 5:00 PM EST**. The primary purpose is to provide participating Offerors with the opportunity to ask questions, in writing, related to the RFP.

Submit questions in a Word Document or in the body of an email and send to Juan Rodriguez-Cruz Juan.Rodriguez-Cruz@unioncountync.gov by the deadline shown above. **The email subject line should identify the proposal number and project title.** All questions and answers may be posted as addenda on www.unioncountync.gov and/or <https://evp.nc.gov>

2.5 PROPOSAL ADDENDUM

Union County may modify the RFP prior to the date fixed for submission of proposals by the issuance of an addendum.

Should an Offeror find discrepancies or omissions in this RFP or any other documents provided by Union County, the Offeror should immediately notify the County of such potential discrepancy in writing via email as noted above.

Any addenda to these documents shall be issued in writing. No oral statements, explanations, or commitments by anyone shall be of effect unless incorporated in the written addenda. Receipt of Addenda shall be acknowledged by the Offeror on Appendix C – Addendum and Anti-Collusion form.

2.6 COMMUNICATION

All communications, any modifications, clarifications, amendments, questions, responses or any other matters related to this Request for Proposals must be made only through the Procurement Contact noted on the cover of this RFP. A violation of this provision is cause for the County to reject a Company's proposal. No contact regarding this document with other County employees is permitted and may be grounds for disqualification.

3 PURPOSE

3.1 COUNTY

The County (estimated population 239,859) is located in the central, southern piedmont. The County provides its citizens with a full array of services that include public safety, water/wastewater utilities and sanitation, human services, cultural and recreational activities, and general government administration.

3.2 INTRODUCTION

Union County (hereafter the "County"), through Union County Water, is soliciting proposals from qualified contractors for aeration tank cleaning services.

4 SCOPE OF SERVICES

4.1 SCOPE OF WORK SUMMARY

Union County Water desires to have all rags, grit, sludge and debris removed and disposed of from one aeration basin at its Twelve Mile Creek WRF located at 8299 Kensington Dr Waxhaw NC 28173. Contractor shall furnish all permits, labor, materials and equipment required to remove, transport, and dispose of materials removed from the aeration tank. Contractor shall perform all services in strict accordance with all Applicable Law. Within twenty-four (24) hours of occurrence, Contractor shall provide UCPW with written notice of violation or noncompliance with respect to Contractor's permit(s), UCPW's permit(s), or of any action commenced in any court of competent jurisdiction involving the operations conducted by Contractor during the duration of this contract.

Contractor shall coordinate scheduling with plant operations staff. The Twelve Mile Creek WRF is currently under construction. Contractor activities shall be coordinated so as not to interfere with ongoing construction operations. Union County will coordinate work in construction areas to satisfy the operational needs of both contractors and the County. All work must be scheduled in advance, and Contractor shall provide daily status updates to Union County regarding work performed, planned activities, and any issues encountered.

If a dewatering or decanting operation will be part of the process, coordinate these activities with the Union County Water and Wastewater point of contact to determine where the water will be disposed of and if at the plant, sampling may be conducted. Metering of the water back into the plant to prevent a plant upset will be required.

Dewatering Performance Requirements:

Dewatering operations shall meet the following minimum performance criteria:

- Cake solids shall be greater than 15 percent (15%).
- Filtrate or centrate solids shall be less than 200 mg/L.
- Ammonia shall be less than 75 mg/L.
- Total phosphorus shall be less than 15 mg/L.

Sampling will be performed randomly by Union County Water Plant Operations staff. All samples will be analyzed on-site by Union County. Results shall be used to verify compliance with performance requirements.

Utilities and Power: Union County will provide water for mobile press units as required. Contractor shall be responsible for supplying and operating a generator to provide power for all mobile press units and associated equipment.

Union County Water Plant Operations reserve the right to halt, suspend, or modify any cleaning, dewatering, or related activities at any time and for any reason, including but not limited to operational needs, safety concerns, regulatory requirements, enforcement of blackout periods, or coordination with other on-site activities. The Contractor shall immediately comply with any such direction from Union County Water staff.

Work to be completed Monday through Friday 7am-5pm.

Blackout Periods:

No work shall be performed during the following blackout periods:

- January 26, 2026 through February 6, 2026
- April 27, 2026 through May 8, 2026
- July 27, 2026 through August 7, 2026
- October 26, 2026 through November 6, 2026

If the project duration extends beyond these dates, additional blackout periods may be identified by Union County and incorporated as needed. No work shall be performed on weekends or on Union County–recognized holidays.

Approximate area of debris 240'L X 58'W X 1' H

4.2 SAFETY

The Offeror shall provide all employees with necessary personal protective equipment such as industry specific clothing, head, respiratory, eye, hand and foot protection.

4.3 SPECIAL REQUIREMENTS

- Ongoing Regulatory Compliance: Contractor must possess and maintain all appropriate permits, plans, equipment, facilities, and personnel necessary to safely accept, transport and deliver County bio-solids in a manner consistent with all applicable state federal and local requirements. Contractor must appropriately document bio-solids transport as required by law and must produce such records as requested by the County.
- Operations in good standing: Contractor shall have in effect no current enforcement actions against their operations pertaining to bio-solids transport. Contractor shall maintain a satisfactory safety record for the duration of this contract. This includes but is not limited to notices of violation, orders, penalties, or other enforcement actions restricting relevant activities.
- Adequate hauling equipment: All equipment supplied and/or utilized under this contract must be of adequate design and condition to safely, satisfactorily, and legally accept, transport, and transfer bio-solids as required. A minimum 3,000-gallon tanker equipped to load and discharge by on-board pump shall be required. Tanker shall be free of contaminants that could cause harm to the receiving WRF.
- Spill response capabilities: Contractor must operate all equipment utilized under this contract in such manner as to prevent spillage during transport. However, in case of unavoidable spills, Contractor must promptly and adequately respond to spills in such a manner as to maintain regulatory compliance and minimize harm to the affected environment, people and equipment. Contractor must immediately report any spill incidents to the County and other appropriate parties, per spill response plans.
- Stormwater Protection and Spill Prevention: Contractor shall install and maintain stormwater pollution prevention measures sufficient to prevent, contain, and control spills or releases associated with the work. Contractor shall maintain an appropriate spill kit on site at all times. A stormwater map is provided as an attachment to this RFP for informational purposes.
- Chemical Use and Safety Data Sheets: Contractor shall submit Safety Data Sheets (SDS) for all chemicals proposed for use to the Plant Supervisor and obtain written approval from the Plant Supervisor prior to bringing or using any chemicals on site.

5 DETAILED SUBMITTAL REQUIREMENTS AND INSTRUCTIONS

5.1 TERMS OF SUBMISSION

All material received from a person or company (“Offeror”) in response to this solicitation shall become the property of Union County and will not be returned to the Offeror. Any and all costs incurred by an Offeror in preparing, submitting, or presenting submissions are the Offeror’s sole responsibility and Union County shall not reimburse the Offeror. All responses to this solicitation will be considered a public record and subject to disclosure under applicable public records law.

Any material in a response which the Offeror considers a trade secret and exempt from disclosure as a public record under applicable law, including N.C.G.S. §§ 132-1.2 and 66-152, must be properly designated as a trade secret. In order to properly designate such material, the Offeror must: (i) submit any trade secret materials in a separate envelope, or file, from all other submitted material, being clearly marked as “Trade Secret – Confidential and Proprietary Information,” and (ii) stamp the same trade secret/confidentiality designation on each page of the materials therein which contain trade secrets.

To the extent consistent with public records law, Union County will make reasonable efforts to maintain the confidential nature of trade secrets, as determined by Union County and subject to the conditions set forth herein. Offeror understands and agrees by submitting a response to this solicitation, that if a request is made to review or produce a copy of any information in the Offeror materials which was properly labeled by the Offeror as a trade secret, Union County will notify the Offeror of the request and the date that such materials will be released to the requestor unless the Offeror obtains a court order enjoining that disclosure. If the Offeror fails to obtain the court order enjoining disclosure prior to that date, Offeror understands and agrees that Union County will release the requested information to the requestor on that date.

Furthermore, the Offeror also agrees to indemnify and hold harmless Union County and each of its officers, employees, and agents from all costs, damages, and expenses incurred in connection with refusing to disclose any material that has been designated as a trade secret by Offeror.

5.2 DUPLICATE PROPOSALS

No more than one (1) proposal from any Offeror will be considered by the County. In the event multiple proposals are submitted in violation of this provision, the County will have the right to determine which proposal will be considered, or at its sole option, reject all such multiple proposals.

5.3 PROPOSAL FORMAT

The County desires all responses to be identical in format in order to facilitate comparison. While the County's format may represent a departure from the vendor's preference, the County requests adherence to the format. All responses are to be in the format described below.

Offerors should prepare their proposals in accordance with the instructions outlined in this section. Each Offeror is required to submit the proposal electronically – Refer to page 4, item 2.2. Each section should be identified as described below. Proposals should be prepared as simply as possible and provide a straightforward, concise description of the proposer's capabilities to satisfy the requirements of the RFP.

The County may award a contract based on initial offers received without discussion of such offers. A proposer's initial offer should, therefore, be based on the most favorable terms available. The County reserves the right to contact proposers regarding cost and scope clarification at any time throughout the selection process.

The successful Offeror's proposal must include all responses to the requirements contained within this RFP and all appendices (if applicable) must be completed in their entirety.

By submitting a proposal, the successful Offeror's Offeror agrees to all applicable provisions, terms and conditions associated with this RFP. This solicitation, the successful Offeror's submitted proposal, all appendices and attachments (if applicable), and stated terms and conditions may become part of the resulting contract.

Utmost attention should be given to accuracy, completeness, and clarity of content. All parts, pages, figures, or tables should be numbered and clearly labeled. Response information should be limited to pertinent information only. Marketing and sales type information is not to be included.

Omissions and incomplete answers may be deemed unresponsive. Please initial any corrections.

The proposal should be organized and identified by section as follows:

- **Section A** – Cover Letter
- **Section B** – Company Background and Experience
- **Section C** – Project Team
- **Section D** – Methodology and Implementation Plan
- **Section E** - References
- **Section F** – Proposed Pricing
 - Appendix A – Price Form (completed); submit with proposal
- **Section G** – Required Forms
 - Appendix B – Proposal Submission (signed)
 - Appendix C - Addenda Receipt and Anti-Collusion (signed)

5.3.1 SECTION A – COVER LETTER

Provide the following information about your company. Respond to each item and provide supporting documentation and/or exhibits as requested or desired.

1. Legal Company Name and DBA (if applicable)
Address
Telephone Number
Website Address
Name of Single Point of Contact
Title
Telephone Number
Email Address
2. Name of Person with Binding Authority
Title
Address
Telephone Number
Email Address
3. Stipulate that the proposal price will be valid for a period of 180 days.
4. Make the following representations and warranty in the cover letter, the falsity of which might result in rejection of its proposal: “The information contained in this proposal or any part thereof, including any exhibits, schedules, and other documents and instruments delivered or to be delivered to the County, is true, accurate, and complete. This proposal includes all information necessary to ensure that the statements therein do not in whole or in part mislead the County as to any material facts.”

5.3.2 SECTION B – COMPANY BACKGROUND AND EXPERIENCE

This section provides each vendor with the opportunity of demonstrating how its history, organization, and partnerships differentiate it from other entities. Careful attention should be paid to providing information relevant to Union County needs.

Provide a concise profile of the Proposer’s organization to include the following:

- Corporate history, and number of years in business under the current organizational name, structure and services offered.
- Assets available to meet County service requirements.
- Is the Offeror’s organization involved in any pending litigation that may affect its ability to provide its products and services?

5.3.3 SECTION C – PROJECT TEAM

Describe the professional staff to be associated with this project. Upon award and during the contract period, if the contractor chooses to assign different personnel to the project, the Contractor must submit their names and qualifications including information listed above to the County for approval before they begin work. At a

minimum, this section should include the following information for each key person identified by the company:

- Name and title
- Project responsibilities and roles
- Involvement levels & durations
- Years of relevant experience
- Length of service with the company

5.3.4 SECTION D - METHODOLOGY AND IMPLEMENTATION PLAN

Provide a description of the approach and methodology to be used to accomplish the Scope of Work of this RFP. The Methodology Section should include:

- An implementation plan that describes the methods, including controls, by which your firm manages projects of the type.
- Project management, implementation strategies or techniques that the Offeror intends to use in carrying out the work.
- Brief description of efforts your firm will undertake to achieve client satisfaction and to satisfy the requirements of this solicitation.
- Brief description of specific tasks you will require from County staff. Explain what the respective roles of County staff and your staff would be to complete the tasks specified.

5.3.5 SECTION F – REFERENCES

- Provide, at a minimum, three (3) comparable clients with whom your firm has an established relationship similar to the Scope of Work outlined in this RFP and include the following:
 - Company Name
 - Contact Name and Title
 - Address
 - Phone Number
 - Email Address
 - Project name
 - Length of Relationship

5.3.6 SECTION G – PRICE FORM

Complete Appendix A – Price Form and submit with proposal.

5.3.7 SECTION H – REQUIRED FORMS

Offerors must include signed copies of the following documents:

- Appendix B – Proposal Submission (signed)
- Appendix C – Addenda Receipt and Anti-Collusion (signed)

6 EVALUATION CRITERIA AND SELECTION PROCESS

6.1 SELECTION PARTICIPANTS

1. Maintaining the integrity of the RFP process is of paramount importance for the County. To this end, please do not contact any members of Union County or its staff regarding the subject matter of this RFP until a selection has been made, other than the County's designated contact person identified in the introduction to this RFP.
2. Representatives of Union County will read, review, and evaluate the RFP independently based on the evaluation criteria. Failure to abide by this requirement shall be grounds for disqualification from this selection process.
3. The County will establish an RFP Evaluation Team to review and evaluate the RFPs. The RFP Evaluation Team will assess the RFPs independently in accordance with the published evaluation criteria. Union County reserves the right to conduct interviews with a shortlist of selected Offerors.
4. At its sole discretion, the Owner may ask written questions of Offerors, seek written clarification, and conduct discussions with Offerors on the RFPs.

The County reserves the right to determine the suitability of proposals on the basis of a proposal meeting scope and submittal criteria listed in the RFP. Evaluation criteria and other relevant RFP information will be used to assist in determining the finalist Vendor.

6.2 FINANCIAL INFORMATION

Offeror may be asked to provide the following financial information. If the following financial information is requested, it shall be readily available and provided to the County within forty-eight (48) hours upon request during the bid certification process:

1. Annual audited financial reports for the past five (5) fiscal years;
2. Credit reports, credit bulletins, bank and vendor references, and any other published statements by agencies that have been issued or published about the entity within the past five (5) years;
3. Indicate whether the Company (and/or predecessor, guarantor, or subcontractor) has declared bankruptcy within the last five (5) years;
4. Provide a description of the financial impact of any past or pending legal proceedings and judgments that could materially affect the Offeror's financial position or ability to provide service to the County.

6.3 EVALUATION SELECTION PROCESS

A weighted analysis of the evaluation criteria will be utilized to determine the Vendor that represents the best value solution for the County.

In the evaluation and scoring/ranking of Offerors, the County will consider the information submitted in the RFP as well as the meetings (if applicable) with respect to the evaluation criteria set forth in the RFP.

The initial evaluation criteria/factors and relative weights listed below will be used to recommend selection of the Proposed Offeror or for the purpose of selecting Short-Listed Offerors. The County may choose to award without engaging in interview discussions.

RFP Criteria	Weights
Company Background and Experience	40%
Project Team, Methodology & Implementation Plan	35%
Price	15%
Compliance with Submittal Requirements	10%

Vendors may be invited to give a demonstration of the capabilities of the proposed solution to the Union County evaluation team. The successful bidder’s demonstration (if requested), along with questions and answers, will be a critical component of the overall vendor evaluation.

After identification of Short-Listed Offerors, the County may or may not decide to invite Short-Listed Offerors to vendor demonstration/interviews. If interviews are scheduled with the Short-Listed Offerors, previous evaluation and rankings are not carried forward. For the purpose of selecting a Preferred Offeror, the evaluation criteria will be given the following relative weights:

Interview Criteria	Weights
Proposed Approach & Staff	60%
Price, Quality and Relevance of Interview as it Relates to the Scope of the RFP	40%

Additional meetings may be held to clarify issues or to address comments, as deemed appropriate. Proposers will be notified in advance of the time and format of such meetings.

6.4 AWARD PROCEDURE

Union County has the right to reject any or all proposals, to engage in further negotiations with any Company submitting a proposal, and/or to request additional information or clarification. The County is not obligated to accept the lowest cost proposal. The County may accept the proposal that best serves its needs, as determined by County officials in their sole discretion.

The County reserves the right to make an award without further discussion of the proposals received. Therefore, it is important that the proposal be submitted initially on the most favorable terms.

A proposal may be rejected if it is incomplete. Union County may reject any or all proposals and may waive any immaterial deviation in a proposal.

More than one proposal from an individual, Offeror, partnership, corporation or association under the same or different names, will not be considered.

The County reserves the right to enter into negotiations with the top ranked Offeror. However, negotiations with the top ranked Offeror does not signify a commitment by Union County to execute a contract or to continue discussions.

The County reserves the right to terminate negotiations at any time and for any reason. The County may select and enter into negotiations with the next most advantageous Proposer if negotiations with the initially chosen Proposer are not successful.

The award shall be made in the best interest of the County. This Request for Proposal is not subject to any competitive bidding requirements of North Carolina law. The County reserves the right to accept other than the most financially advantageous proposal.

The award document will be a Contract incorporating, by reference, all the requirements, terms and conditions of the solicitation and the Offeror's proposal as negotiated.

6.5 CONFLICT CERTIFICATION

The Offeror must certify that it does not have any actual or potential conflicts of interest with, or adversarial litigation against the County or any of its officers or employees. During the course of the contractual relationship formed pursuant to this solicitation, any such conflict of interest, whether newly arising or newly discovered, must be disclosed to the County in writing.

7 GENERAL CONDITIONS AND REQUIREMENTS

7.1 TERMS AND CONDITIONS

Union County has the right to reject any or all proposals, to engage in further negotiations with any Company submitting a proposal, and/or to request additional information or clarification. The County is not obligated to accept the lowest cost proposal. The County may accept that proposal that best serves its needs, as determined by County officials in their sole discretion.

All payroll taxes, liability and worker's compensation are the sole responsibility of the Offeror. The Offeror understands that an employer/employee relationship does not exist under this contract.

All proposals submitted in response to this request shall become the property of Union County and as such, may be subject to public review.

7.2 CONTRACTUAL OBLIGATIONS

The contents of this Proposal and the commitments set forth in the selected Proposal(s) shall be considered contractual obligations, if a contract ensues. Failure to accept these obligations may result in cancellation of the award. All legally required terms and conditions shall be incorporated into final contract agreements with the selected Service Provider(s).

7.3 SUB-CONTRACTOR/PARTNER DISCLOSURE

If the proposal by any Company requires the use of sub-contractors, partners, and/or third-party products or services, this must be clearly stated in the proposal. The Company submitting the proposal shall remain solely responsible for the performance of all work, including work that is done by sub-contractors.

7.4 EXCEPTION TO THE PROPOSAL

An “exception” is defined as the Service Provider’s inability or unwillingness to meet a term, condition, specification, or requirement in the manner specified in the Proposal. All exceptions taken must be identified and explained in writing in the proposal and must specifically reference the relevant section(s) of this Proposal. Other than exceptions that are stated in compliance with this Section, each proposal shall be deemed to agree to comply with all terms, conditions, specifications, and requirements of this Proposal. If the Service Provider provides an alternate solution when taking an exception to a requirement, the benefits of this alternate solution and impact, if any, on any part of the remainder of the Service Provider’s solution, must be described in detail.

7.5 MODIFICATION OR WITHDRAWAL OF PROPOSAL

Prior to the scheduled closing time for receiving proposals, any Vendor may withdraw their proposal. After the scheduled closing time for receiving proposals, no proposal may be withdrawn for 180 days. Only written requests for the modification or correction of a previously submitted proposal that are addressed in the same manner as proposals and are received by the County prior to the closing time for receiving proposals will be accepted. The proposal will be corrected in accordance with such written requests, provided that any such written request is in a sealed envelope that is plainly marked “Modification of Proposal” – with solicitation number and name on the front of the envelope. Oral, telephone, or fax modifications or corrections will not be recognized or considered.

7.6 EQUAL EMPLOYMENT OPPORTUNITY

All Offerors will be required to follow Federal Equal Employment Opportunity (EEO) policies. Union County will affirmatively assure that on any project constructed pursuant to this advertisement, equal employment opportunity will be offered to all persons without regard to race, color, creed, religion, national origin, sex, and marital status, status with regard to public assistance, membership or activity in a local commission, disability, sexual orientation, or age.

7.7 MINORITY BUSINESSES OR DISADVANTAGED BUSINESSES

It is the policy of Union County that Minority Businesses (MBEs), Disadvantaged Business Enterprises (DBEs) and other small businesses shall have the opportunity to compete fairly in contracts financed in whole or in part with public funds. Consistent with this policy, Union County will not allow any person or business to be excluded from participation in, denied the benefits of, or otherwise be discriminated against in connection with the award and performance of any contract because of sex, race, religion, or national origin.

7.8 LICENSES

The successful Offeror(s) shall have and maintain a valid and appropriate business license (if applicable), meet all local, state, and federal codes, and have current all required local, state, and federal licenses.

7.9 E-VERIFY

E-Verify is the federal program operated by the United States Department of Homeland Security and other federal agencies, or any successor or equivalent program, used to verify the work authorization of newly hired employees pursuant to federal law. Vendor/Offeror shall ensure that Offeror and any Sub-Contractor performing work under this contract: (i) uses E-Verify if required to do so; and (ii) otherwise complies with applicable law.

7.10 DRUG-FREE WORKPLACE

During the performance of this Request, the Offeror agrees to provide a drug-free workplace for their employees; post in conspicuous places, available to employees and applicants for employment, a statement notifying employees that the unlawful manufacture, sale, distribution, dispensation, possession, or use of a controlled substance or marijuana is prohibited in the workplace and specify the actions that will be taken against employees for violations of such prohibition; and state in all solicitations or advertisements for employees placed by or on behalf of the Offeror that the Offeror maintains a drug-free workplace.

For the purposes of this section, “drug-free workplace” means a site for the performance of work done in connection with a specific contract awarded to a Offeror/Offerors in accordance with this chapter, the employees of whom are prohibited from engaging in the unlawful manufacture, sale, distribution, dispensation, possession or use of any controlled substance or marijuana during the performance of the Request.

7.11 INSURANCE

One or more of the following insurance limits may be required if it is applicable to the project. The County reserves the right to require additional insurance depending on the nature of the agreement.

At Contractor’s sole expense, Contractor shall procure and maintain the following minimum insurances with insurers authorized to do business in North Carolina and rated A-VII or better by A.M. Best, or as otherwise authorized by the Union County Risk Manager.

- A. **WORKERS' COMPENSATION**
 Statutory (coverage for three or more employees) limits covering all employees, including Employer's Liability with limits of:
 \$500,000 Each Accident
 \$500,000 Disease - Each Employee
 \$500,000 Disease - Policy Limit
- B. **COMMERCIAL GENERAL LIABILITY**
 (for any agreement unless otherwise waived by the Risk Manager)
 Covering Ongoing and Completed Operations involved in this Agreement.
- \$2,000,000 General Aggregate
 \$2,000,000 Products/Completed Operations Aggregate
 \$1,000,000 Each Occurrence
 \$1,000,000 Personal and Advertising Injury Limit
- C. **COMMERCIAL AUTOMOBILE LIABILITY**
 (for any agreement involving the use of a contractor vehicle while conducting services associated with the agreement)
- \$1,000,000 Combined Single Limit - Any Auto
- D. **PROFESSIONAL LIABILITY**
 (only for any agreement providing professional service such as engineering, architecture, surveying, consulting services, etc.)
- \$1,000,000 Claims Made
- E. **NETWORK SECURITY & PRIVACY LIABILITY (CYBER)**
 (for any agreement involving software applications)
- \$1,000,000 Claims Made
- Contractor shall provide evidence of continuation or renewal of Professional Liability Insurance for a period of two (2) years following termination of the Agreement.

ADDITIONAL INSURANCE REQUIREMENTS

- A. The Contractor's General Liability policy shall be endorsed, specifically or generally, to include the following as Additional Insured:
- UNION COUNTY, ITS OFFICERS, AGENTS AND EMPLOYEES ARE INCLUDED AS ADDITIONAL INSURED WITH RESPECTS TO THE GENERAL LIABILITY INSURANCE POLICY.**
- Additional Insured status for Completed Operations shall extend for a period of not less than three (3) years from the date of final payment.

- B. Before commencement of any work or event, Contractor shall provide a Certificate of Insurance in satisfactory form as evidence of the insurances required above.
- C. Contractor shall have no right of recovery or subrogation against Union County (including its officers, agents and employees).
- D. It is the intention of the parties that the insurance policies afforded by contractor shall protect both parties and be primary and non-contributory coverage for any and all losses covered by the above-described insurance.
- E. Union County shall have no liability with respect to Contractor's personal property whether insured or not insured. Any deductible or self-insured retention is the sole responsibility of Contractor.
- F. Notwithstanding the notification requirements of the Insurer, Contractor hereby agrees to notify County's Risk Manager at 500 N. Main Street # 130, Monroe, NC 28112, within two (2) days of the cancellation or substantive change of any insurance policy set out herein. Union, in its sole discretion, may deem failure to provide such notice as a breach of this Agreement.
- G. The Certificate of Insurance should note in the Description of Operations the following:

Department: _____
Contract #: _____

- H. Insurance procured by Contractor shall not reduce nor limit Contractor's contractual obligation to indemnify, save harmless and defend Union County for claims made or suits brought which result from or are in connection with the performance of this Agreement.
- I. Certificate Holder shall be listed as follows:

Union County
Attention: Union County Risk Manager
500 N. Main Street, Suite #130
Monroe, NC 28112
- J. If Contractor is authorized to assign or subcontract any of its rights or duties hereunder and in fact does so, Contractor shall ensure that the assignee or subcontractor satisfies all requirements of this Agreement, including, but not limited to, maintenance of the required insurances coverage and provision of certificate(s) of insurance and additional insured endorsement(s), in proper form prior to commencement of services.

7.12 INDEMNIFICATION

Contractor agrees to protect, defend, indemnify and hold Union County, its officers, employees and agents free and harmless from and against any and all losses, penalties, damages, settlements, costs, charges, professional fees or other expenses or liabilities of every kind and character arising out of or relating to any and all claims, liens, demands, obligations, actions, proceedings, or causes of action of every kind in connection with or arising out of this agreement and/or the performance hereof that are due, in whole or in part, to the negligence of the Contractor, its officers, employees, subcontractors or agents. Contractor further agrees to investigate, handle, respond to, provide defense for, and defend the same at its sole expense and agrees to bear all other costs and expenses related thereto.

8 APPENDIX A – PRICE FORM

RFP 2026-044 Aeration Tank Cleaning
Submit with Proposal

Company Name _____

DESCRIPTION	MOBILIZATION	DEMobilIZATION	PRICE PER WET TON	ESTIMATED VOLUME TO BE REMOVED (WET TONS)	ESTIMATED TOTAL PRICE
Refer to section 4. Scope of Services					\$

Note: The estimated volume to be removed and the estimated total price are provided for budgeting and comparison purposes only. Actual quantities will be determined during performance of the work. Evaluation of pricing will be based primarily on mobilization costs, demobilization costs, and the price per wet ton.

9 APPENDIX B – PROPOSAL SUBMISSION

RFP 2026-044 Aeration Tank Cleaning

Submit with Proposal

This Proposal is submitted by:

Company Legal Name: _____

Representative Name: _____

Representative Signature: _____

Representative Title: _____

Address: _____

County/State/Zip: _____

Email Address: _____

Phone Number: _____

Website Address: _____

It is understood that Union County reserves the right to reject any and all proposals, to make awards according to the best interest of the County, to waive formalities, technicalities, to recover and re-advertise this project. Proposal is valid for 180 days. Proposal is submitted by an executive of the company that has authority to contract with Union County, NC.

Name: _____

Title: _____

Required Signature: _____

Date: _____

10 APPENDIX C – ADDENDUM AND ANTI-COLLUSION

RFP 2026-044 Aeration Tank Cleaning

Submit with Proposal

Please acknowledge receipt of all addenda by including this form with your Proposal. Any questions or changes received will be posted as an addendum on unioncountync.gov and/or <https://evp.nc.gov>. It is your responsibility to check for this information.

Addendum No.	Date Downloaded
_____	_____
_____	_____
_____	_____
_____	_____

I certify that this proposal is made in good faith and without collusion with any other offeror or officer or employee of Union County.

Company Name: _____

Name: _____

Title: _____

Email Address: _____

Signature: _____

Date: _____

11 APPENDIX D – AERATION TANK DRAWINGS

RFP 2026-044 Aeration Tank Cleaning

Informational Purposes Only - Do not submit with proposal.



Request for Proposals No. 2026-044 **Aeration Tank Cleaning**

Due Date: March 10, 2026
Time: 11:00 AM EST
Receipt Location: Electronic Submission (Refer to Section 2)
Union County Procurement and Contract
Management Department
(Note: Follow the submittal instructions in Section 2.2
to electronically upload a proposal package.)

Non-Mandatory Pre-Proposal Conference and Site Visit. February 11, 2026. For the
time and location, Refer to page 3 for details.

Procurement Contact:

Juan Rodriguez-Cruz
Procurement Specialist
704.283.3519
Juan.Rodriguez-Cruz@unioncountync.gov

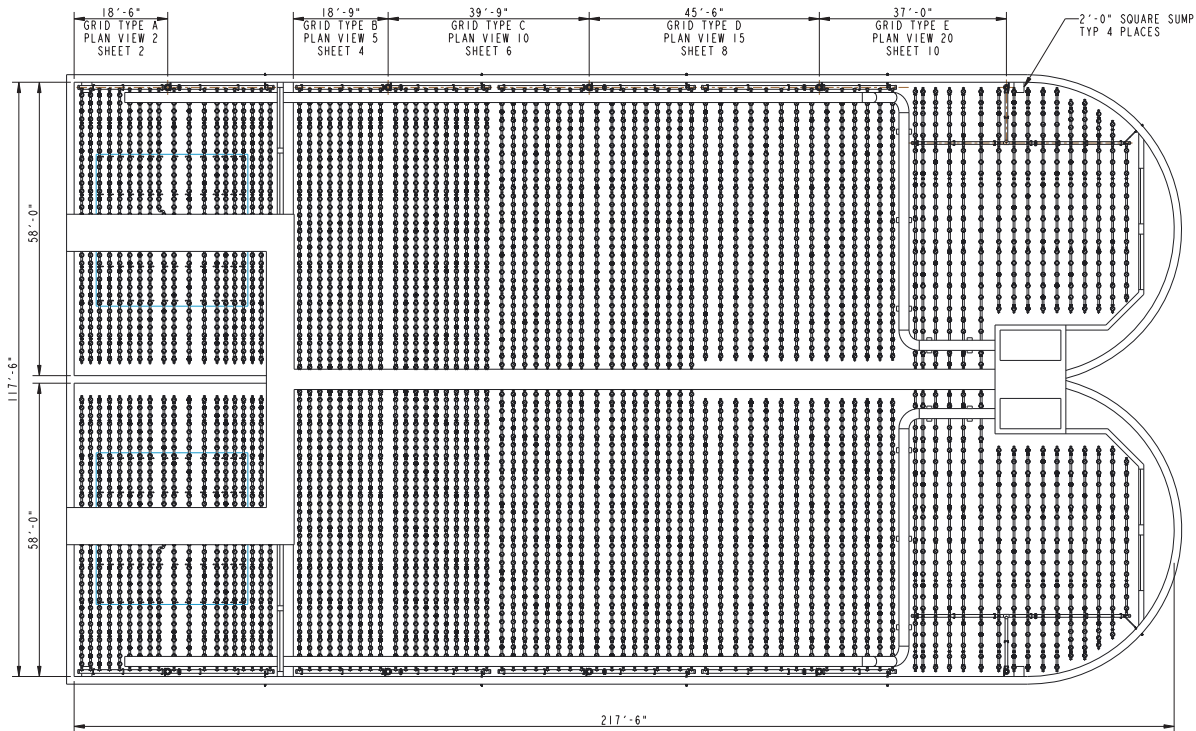

KEY PLAN ①

TANKS 1 AND 2 AS SHOWN
TANKS 5 AND 6 IDENTICAL

NOTE:
PLEASE VERIFY ALL DIMENSIONS AND ELEVATIONS, INCLUDING: INSIDE TANK DIMENSIONS, DROPLEG LOCATIONS, ELEVATIONS OF DROPLEGS CONNECTIONS, FACE OF FLANGES, DIFFUSER ELEVATIONS, FLAT FLOOR AND HIGHPOINT/LOWPOINT ELEVATIONS OF SLOPED FLOOR.

MEMORANDUM BASIC AERATION SYSTEM MATERIAL AND MANUFACTURING SPECIFICATIONS (304L - PVC)			
ITEM	MATERIAL SPECIFICATION	MANUFACTURING SPECIFICATION	NOTES
DROPLEG	304L STAINLESS STEEL ASTM A240	FITTINGS: ASTM A774 TUBULAM PRODUCTS: ASTM A774 DIMENSIONS: ASTM A554	120# DRILLING FOR TERMINATION FLANGE CONNECTION, 30 DEGREE 35 OR 1/8 WALL THICKNESS ON DROPLEG. *SEE BELOW
SUPPORTS	304L STAINLESS STEEL SHEET & PLATE PER ASTM A240 THICKNESS 300 PER ASTM A276		1/4" GRADE NOT REQUIRED FOR NON-WELDED PARTS
BOLTS, NUTS, BRUSHES	18-8 STAINLESS STEEL		
FIXED JOINT O-RING	NATURAL RUBBER/SSR		45#S DORNIETTER SHORE A COMPRESSION 211.50 MAX
MANIFOLD & LOWER DROPLEG	PVC - ASTM D1784 COMPOUND: 12454-B	PIPE: ASTM D1785 FITTINGS: ASTM D2466	
MANIFOLD & AIR DISTRIBUTORS	PVC - ASTM D3015 COMPOUND: 12452-B	PIPE: ASTM D3034 FITTINGS: ASTM D3034	MINIMUM 2% TITANIUM DIOXIDE
DIFFUSER HOLDER SUPPORT	PVC - ASTM D3015 COMPOUND: 12452-A		MINIMUM 2% TITANIUM DIOXIDE
DIFFUSER RING			
DIFFUSER ELEMENT	EPON		
PVC SOLVENT WELDING	ASTM D2564	ASTM D2555	

*STAINLESS STEEL DROPLEG FABRICATION
FACTORY BESS ONLY WITH MIG, TIG, OR PLASMA-ARC WELDING INERT GAS PROCESSES, FULL PENETRATION BUTT WELDS, OR 1/8" FILLER METAL AFTER FABRICATION FINISH CLEAN ALL WELDED STAINLESS STEEL ASSEMBLIES BY FULL IMMERSION CLEANING TECHNIQUES IN ACCORDANCE TO 6.2.11 OF ASTM A380-08. THE ACID FOR USE SET FORTH BY TABLE A2.1 OF PART 12 OF ASTM A380. FINAL RINSE AND DRY IN ACCORDANCE TO SECTION 8.3 OF ASTM A380. ALL WELDED SURFACES TO CONFORM TO A151 NO. 20 FINISH.

AERATION TANK No. 1

AERATION TANK No. 2

VIEW, SECTION, OR
DETAIL NUMBER
XX
X
SHEET NUMBER ON
WHICH VIEW, SECTION,
OR DETAIL IS FOUND

REV	DATE	REVISION	BY
2	03/21/17	CHANGES PER JOB 5, REV SHEET DATED 03/14/17	TJC
1	02/23/17	CHANGES PER JOB 5, REV SHEET DATED 02/28/17	TJC

UNION COUNTY
NORTH CAROLINA
TWELVE MILE CREEK
WASTEWATER TREATMENT PLANT

KEY PLAN



FOR RECORD ONLY.
EQUIPMENT SHOWN
HAS BEEN RELEASED
FOR FABRICATION
xylem
03/21/17

WARNING
xylem DOES NOT ACCEPT RESPONSIBILITY FOR UNDOCUMENTED CUSTOMER INITIATED CHANGES TO ELECTRONICALLY TRANSMITTED DRAWINGS

THIS DRAWING IS THE PROPERTY OF XYLEM AND IS SUBMITTED IN CONFIDENCE. IT IS NOT TO BE DISCLOSED, USED OR DUPLICATED WITHOUT PERMISSION OF XYLEM.

DESIGN BY: TJC	DATE: 01/06/17	SCALE:	PROJECT NO: 16-89905	SHEET NO: 1
CHECK BY: JS	DATE: 02/01/17	SCALE:	PROJECT NO: 16-89905	SHEET NO: 1
APPROV BY: JS	DATE: 02/01/17	SCALE: E-1	PROJECT NO: 16-89905	SHEET NO: 1

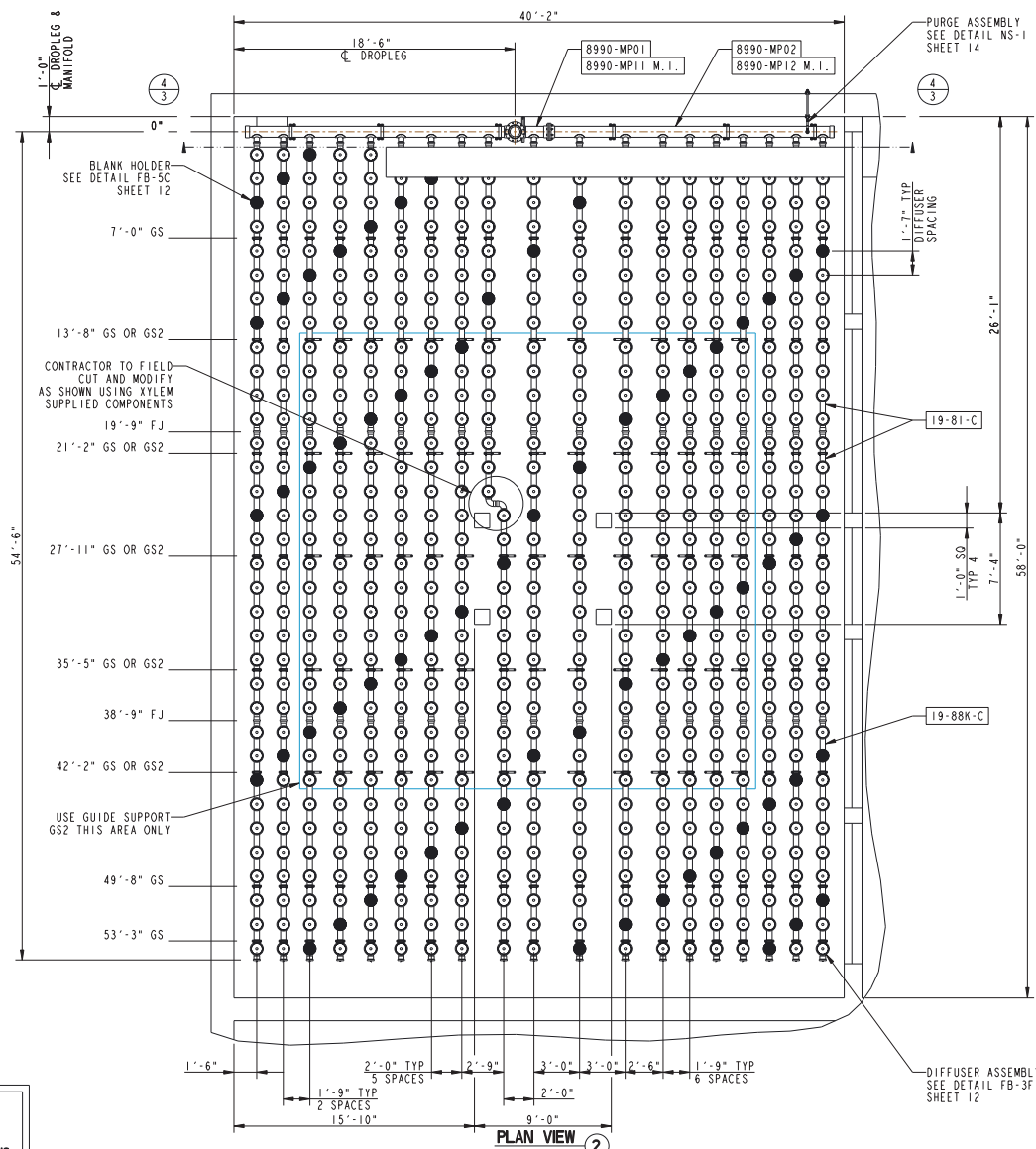

NOTE:
PLEASE VERIFY ALL DIMENSIONS AND ELEVATIONS, INCLUDING: INSIDE TANK DIMENSIONS, DROPLEG LOCATIONS, ELEVATIONS OF DROPLEGS CONNECTIONS, FACE OF FLANGES, DIFFUSER ELEVATIONS, FLAT FLOOR AND HIGHPOINT/LOWPOINT ELEVATIONS OF SLOPED FLOOR.

GRID TYPE A
2 REQ'D AS SHOWN (TANK 1 AND 5)
2 REQ'D MIRROR IMAGE (TANK 2 AND 6)

NOTE: SUPPORT SPACING

Every attempt has been made to insure locational dimensions of the supports are correct. However, after one line of air distributor anchors for any grid type have been installed, the locations must be checked for proper clearances by installing the supplied air headers. Spacing between lines must be checked for fit with the cross manifold and drain line. Any discrepancies or interferences must be brought to the attention of XYLEM prior to further installation.

The actual support anchor locations must be indexed from the centerline of the manifold. The actual accumulative dimensional error from the manifold to the anchor bolt must not exceed $\pm 3/4"$.

GRID TYPE A
4-TANK(S)
1-GRID(S) PER TANK
19-AIR DISTRIBUTORS PER GRID
34-DIFFUSER HOLDERS PER DISTRIBUTOR
VARIES-DIFFUSER ELEMENTS PER DISTRIBUTOR
646-DIFFUSER HOLDERS PER GRID
575-DIFFUSER ELEMENTS INSTALLED PER GRID
2300-TOTAL DIFFUSER ELEMENTS INSTALLED
FOR THIS GRID TYPE
71-BLANKS PER GRID

LEGEND

- FJ - FIXED JOINT
SEE DETAIL FB-10A
SHEET-12
- GS - GUIDE SUPPORT
SEE DETAIL SUP-2
SHEET-13
- GS2 - GUIDE SUPPORT
SEE DETAIL SUP-2A
SHEET-13
- FOR TYPICAL AIR DISTRIBUTOR SECTION
SEE DETAIL FB-22K
SHEET-12

FOR GS & GS2		
TANK	SUPPORT	STRUT
1 & 2	2354-3SP	1878-48
5 & 6	2354-2SP	1878-46

REV	DATE	REVISION	BY

UNION COUNTY
NORTH CAROLINA
TWELVE MILE CREEK
WASTEWATER TREATMENT PLANT

THIS DRAWING IS THE PROPERTY OF XYLEM AND IS SUBMITTED IN CONFIDENCE. IT IS NOT TO BE DISCLOSED, USED OR REPLICATED WITHOUT PERMISSION OF XYLEM.

PLAN VIEW
GRID TYPE A



WARNING
XYLEM DOES NOT ACCEPT RESPONSIBILITY FOR UNDOCUMENTED CUSTOMER INITIATED CHANGES TO ELECTRONICALLY TRANSMITTED DRAWINGS

DESIGNED BY: J.C. DANK 01/06/17	CHECKED BY: J.S. DANK 02/01/17	DATE: 02/01/17	SCALE: E-2	SHEET NO: 2	TOTAL SHEETS: 4
---------------------------------	--------------------------------	----------------	------------	-------------	-----------------

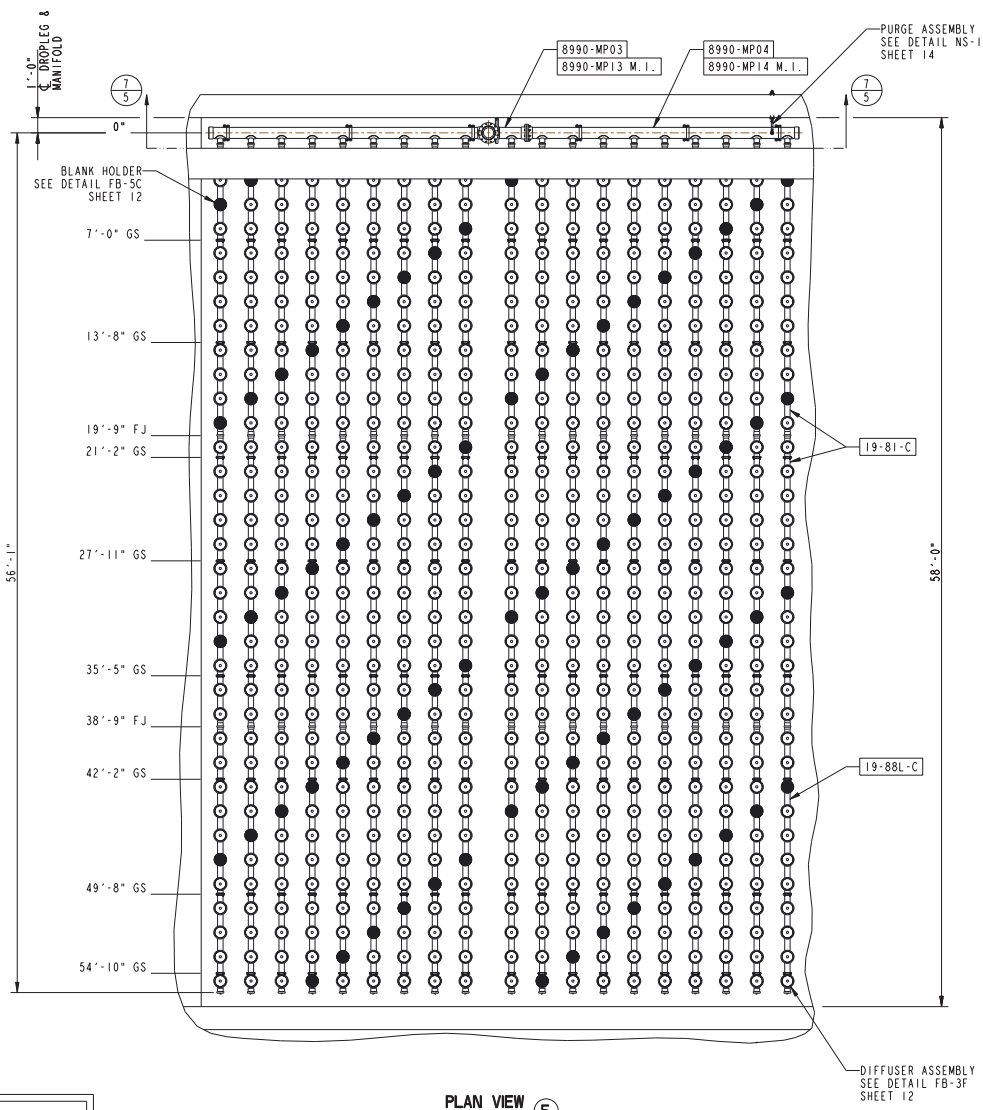

NOTE: SUPPORT SPACING

Every attempt has been made to insure locational dimensions of the supports are correct. However, after one line of air distributor anchors for any grid type have been installed, the locations must be checked for proper clearances by installing the supplied air headers. Spacing between lines must be checked for fit with the cross manifold and drain line. Any discrepancies or interferences must be brought to the attention of XYLEM prior to further installation.

The actual support anchor locations must be indexed from the centerline of the manifold. The actual accumulative dimensional error from the manifold to the anchor bolt must not exceed $\pm 3/4"$.

GRID TYPE B

4-TANK(S)
 1-GRID(S) PER TANK
 19-AIR DISTRIBUTORS PER GRID
 35-DIFFUSER HOLDERS PER DISTRIBUTOR
 VARIES-DIFFUSER ELEMENTS PER DISTRIBUTOR
 665-DIFFUSER HOLDERS PER GRID
 588-DIFFUSER ELEMENTS INSTALLED PER GRID
 2352-TOTAL DIFFUSER ELEMENTS INSTALLED
 FOR THIS GRID TYPE
 77-BLANKS PER GRID

LEGEND

FJ - FIXED JOINT
 SEE DETAIL FB-10A
 SHEET-12

GS - GUIDE SUPPORT
 SEE DETAIL SUP-1
 SHEET-13

FOR GS	
TANK	SUPPORT
1 & 2	2346-3SP
5 & 6	2346-2SP

- FOR TYPICAL AIR DISTRIBUTOR SECTION
 SEE DETAIL FB-22K
 SHEET-12

NOTE:
 PLEASE VERIFY ALL DIMENSIONS AND ELEVATIONS, INCLUDING: INSIDE TANK DIMENSIONS, DROPLEG LOCATIONS, ELEVATIONS OF DROPLEGS CONNECTIONS, FACE OF FLANGES, DIFFUSER CONNECTIONS, FLAT FLOOR AND HIGHPOINT/LOWPOINT ELEVATIONS OF SLOPED FLOOR.

PLAN VIEW 5

GRID TYPE B
 2 REQ'D AS SHOWN (TANK 1 AND 5)
 2 REQ'D MIRROR IMAGE (TANK 2 AND 6)

FOR APPROVAL ONLY.
 NOT FOR CONSTRUCTION.
 xylem
 03/21/17

WARNING
 xylem DOES NOT ACCEPT RESPONSIBILITY FOR UNDOCUMENTED CUSTOMER INITIATED CHANGES TO ELECTRONICALLY TRANSMITTED DRAWINGS

REV	DATE	REVISION	BY

UNION COUNTY
 NORTH CAROLINA
 TWELVE MILE CREEK
 WASTEWATER TREATMENT PLANT

THIS DRAWING IS THE PROPERTY OF XYLEM AND IS SUBMITTED IN CONFIDENCE. IT IS NOT TO BE DISCLOSED, USED OR DUPLICATED WITHOUT PERMISSION OF XYLEM.

PLAN VIEW
 GRID TYPE B

SANITAIRE
 a xylem brand

16-89905
 4 OF 4

DATE BY: J.C. DANE 01/06/17
 CHECK BY: J.S. DANE 02/01/17
 APPROV BY: J.S. DANE 02/01/17

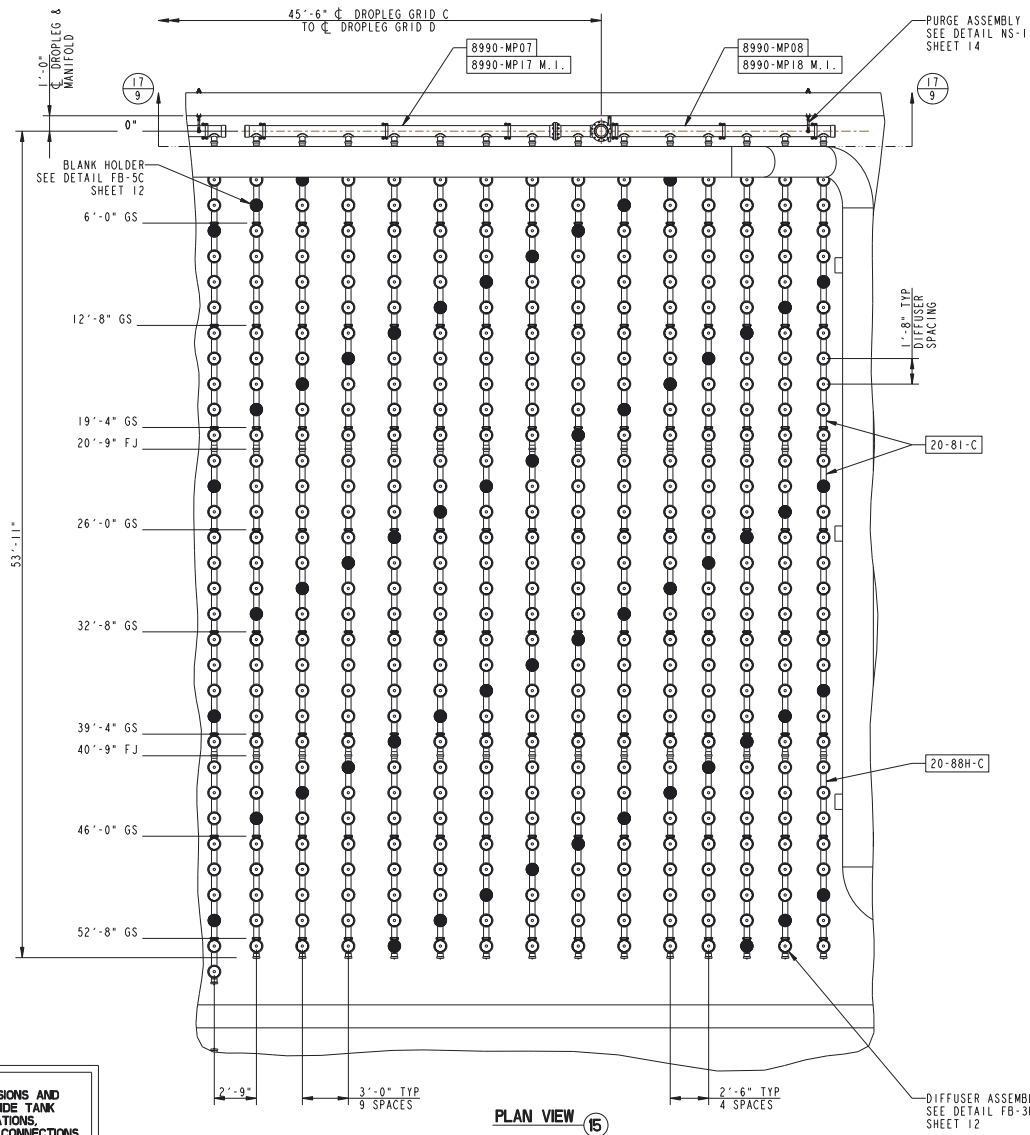

NOTE: SUPPORT SPACING

Every attempt has been made to insure locational dimensions of the supports are correct. However, after one line of air distributor anchors for any grid type have been installed, the locations must be checked for proper clearances by installing the supplied air headers. Spacing between lines must be checked for fit with the cross manifold and drain line. Any discrepancies or interferences must be brought to the attention of XYLEM prior to further installation.

The actual support anchor locations must be indexed from the centerline of the manifold. The actual accumulative dimensional error from the manifold to the anchor bolt must not exceed $\pm 3/4"$.

GRID TYPE D

- 4-TANK(S)
- 1-GRID(S) PER TANK
- 14-AIR DISTRIBUTORS PER GRID
- 32-DIFFUSER HOLDERS PER DISTRIBUTOR
- VARIES-DIFFUSER ELEMENTS PER DISTRIBUTOR
- 448-DIFFUSER HOLDERS PER GRID
- 392-DIFFUSER ELEMENTS INSTALLED PER GRID
- 1568-TOTAL DIFFUSER ELEMENTS INSTALLED
- FOR THIS GRID TYPE
- 56-BLANKS PER GRID

LEGEND

FJ - FIXED JOINT
SEE DETAIL FB-10A
SHEET-12

GS - GUIDE SUPPORT
SEE DETAIL SUP-1
SHEET-13

FOR GS	
TANK	SUPPORT
1 & 2	2346-3SP
5 & 6	2346-2SP

FOR TYPICAL AIR DISTRIBUTOR SECTION
SEE DETAIL FB-22K
SHEET-12

NOTE:
PLEASE VERIFY ALL DIMENSIONS AND ELEVATIONS, INCLUDING: INSIDE TANK DIMENSIONS, DROPLEG LOCATIONS, ELEVATIONS OF DROPLEGS CONNECTIONS, FACE OF FLANGES, DIFFUSER ELEVATIONS, FLAT FLOOR AND HIGHPOINT/LOWPOINT ELEVATIONS OF SLOPED FLOOR.

PLAN VIEW 15

GRID TYPE D
2 REQ'D AS SHOWN (TANK 1 AND 5)
2 REQ'D MIRROR IMAGE (TANK 2 AND 6)

WARNING
XYLEM DOES NOT ACCEPT RESPONSIBILITY FOR UNDOCUMENTED CUSTOMER INITIATED CHANGES TO ELECTRONICALLY TRANSMITTED DRAWINGS

REV	DATE	REVISION	BY

UNION COUNTY
NORTH CAROLINA
TWELVE MILE CREEK
WASTEWATER TREATMENT PLANT

THIS DRAWING IS THE PROPERTY OF XYLEM AND IS SUBMITTED IN CONFIDENCE.
IT IS NOT TO BE DISCLOSED, USED OR DUPLICATED WITHOUT PERMISSION OF XYLEM.

PLAN VIEW
GRID TYPE D

SANITAIRE
a xylem brand

16-8990S 8 OF 14
E-8

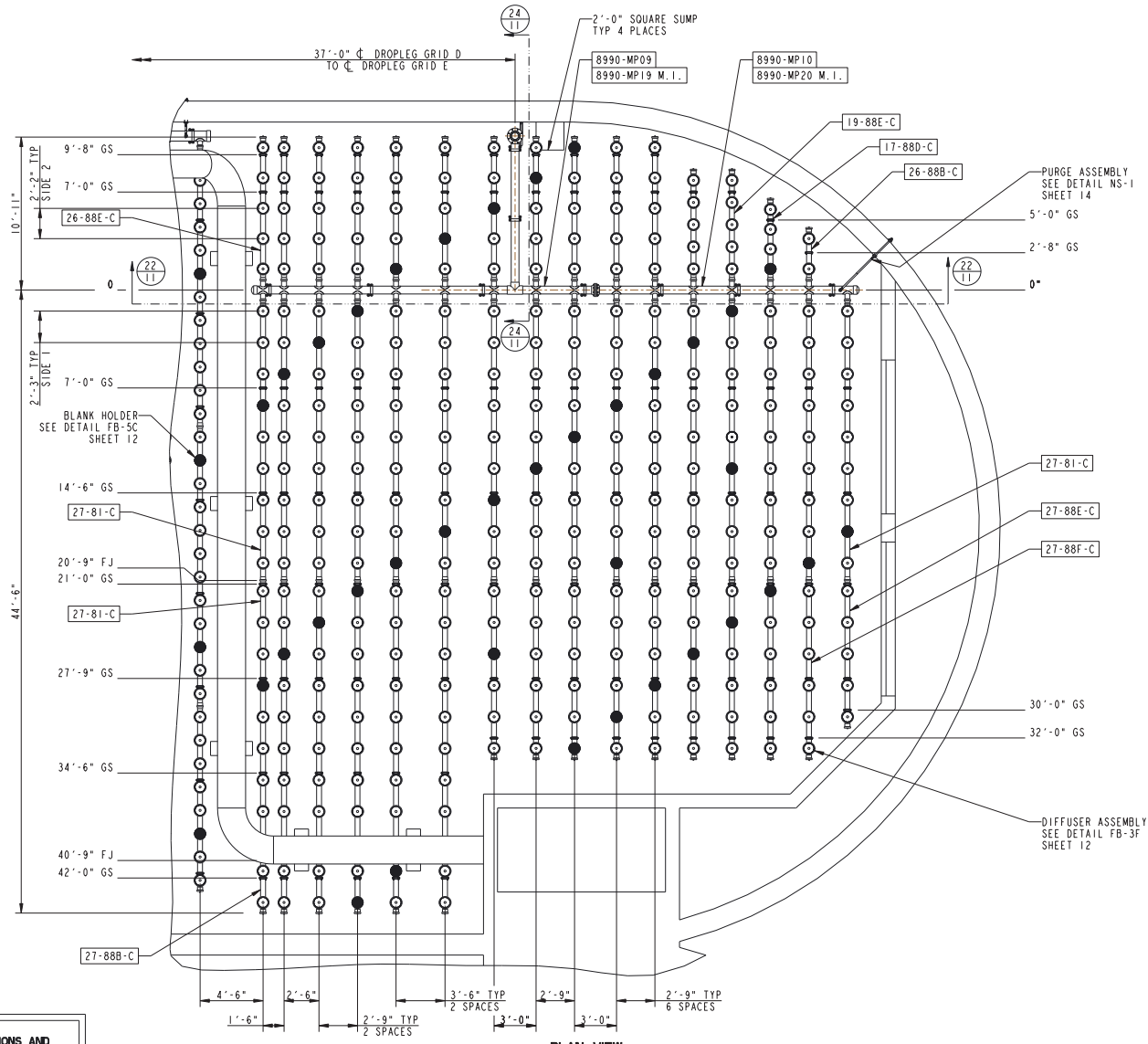

NOTE: SUPPORT SPACING

Every attempt has been made to insure locational dimensions of the supports are correct. However, after one line of air distributor anchors for any grid type have been installed, the locations must be checked for proper clearances by installing the supplied air headers. Spacing between lines must be checked for fit with the cross manifold and drain line. Any discrepancies or interferences must be brought to the attention of XYLEM prior to further installation.

The actual support anchor locations must be inferred from the centerline of the manifold. The actual accumulative dimensional error from the manifold to the anchor bolt must not exceed $\pm 3/4"$.

GRID TYPE E

4-TANK(S)
 1-GRIDS(S) PER TANK
 16-AIR DISTRIBUTORS PER GRID
 VARIES-DIFFUSER HOLDERS PER DISTRIBUTOR
 VARIES-DIFFUSER ELEMENTS PER DISTRIBUTOR
 340-DIFFUSER HOLDERS PER GRID
 303-DIFFUSER ELEMENTS INSTALLED PER GRID
 1212-TOTAL DIFFUSER ELEMENTS INSTALLED
 FOR THIS GRID TYPE
 37-BLANKS PER GRID

LEGEND

FJ - FIXED JOINT
 SEE DETAIL FB-10A
 SHEET-12

GS - GUIDE SUPPORT SEE DETAIL SUP-1 SHEET-13	FOR GS	
	TANK	SUPPORT
	1 & 2	2346-3SP
	5 & 6	2346-2SP

FOR TYPICAL AIR DISTRIBUTOR SECTION
 SEE DETAIL FB-22K
 SHEET-12

NOTE:
 PLEASE VERIFY ALL DIMENSIONS AND ELEVATIONS, INCLUDING INSIDE TANK DIMENSIONS, DROPLEG LOCATIONS, ELEVATIONS OF DROPLEG CONNECTIONS, FACE OF FLANGES, DIFFUSER CONNECTIONS, FLAT FLOOR AND HIGHPOINT/LOWPOINT ELEVATIONS OF SLOPED FLOOR.

PLAN VIEW 20

GRID TYPE E
 2 REQ'D AS SHOWN (TANK 1 AND 5)
 2 REQ'D MIRROR IMAGE (TANK 2 AND 6)

WARNING
 XYLEM DOES NOT ACCEPT RESPONSIBILITY FOR UNDOCUMENTED CUSTOMER INITIATED CHANGES TO ELECTRONICALLY TRANSMITTED DRAWINGS

REV	DATE	REVISION	BY

UNION COUNTY
 NORTH CAROLINA
 TWELVE MILE CREEK
 WASTEWATER TREATMENT PLANT

THIS DRAWING IS THE PROPERTY OF XYLEM AND IS SUBMITTED IN CONFIDENCE. IT IS NOT TO BE DISCLOSED, USED OR REPRODUCED WITHOUT PERMISSION OF XYLEM.

PLAN VIEW
 GRID TYPE E

SANITAIRE
 a xylem brand

16-8990S
 10 OF 14
 E-10

LEGEND

- ▲ DENOTES FIXED PIPE SUPPORT
- △ DENOTES SLIDING PIPE SUPPORT

NOTES:

1. AERATION TANK NO. 1: TYPICAL THREE (3) LOCATIONS: REMOVE MAX 8'-0" LENGTH OF EXIST 8" DRAIN PIPING INCLUDING EXIST PLUG VALVE. INSTALL NEW 8" PD AND 8" PV AND CONNECT TO EXISTING PIPING WITH MEGALUG COUPLINGS.
2. AERATION TANK NO. 2: TYPICAL THREE (3) LOCATIONS: REMOVE EXIST 8" DRAIN PIPING INCLUDING EXIST PLUG VALVE FROM EDGE OF TANK STRUCTURE TO WYE ON DRAIN HEADER. INSTALL MJ PLUG ON WYE. INSTALL NEW 8" PD AND 8" PV AND CONNECT TO EXISTING PIPING WITH MEGALUG COUPLINGS PER DETAIL 1/M303.

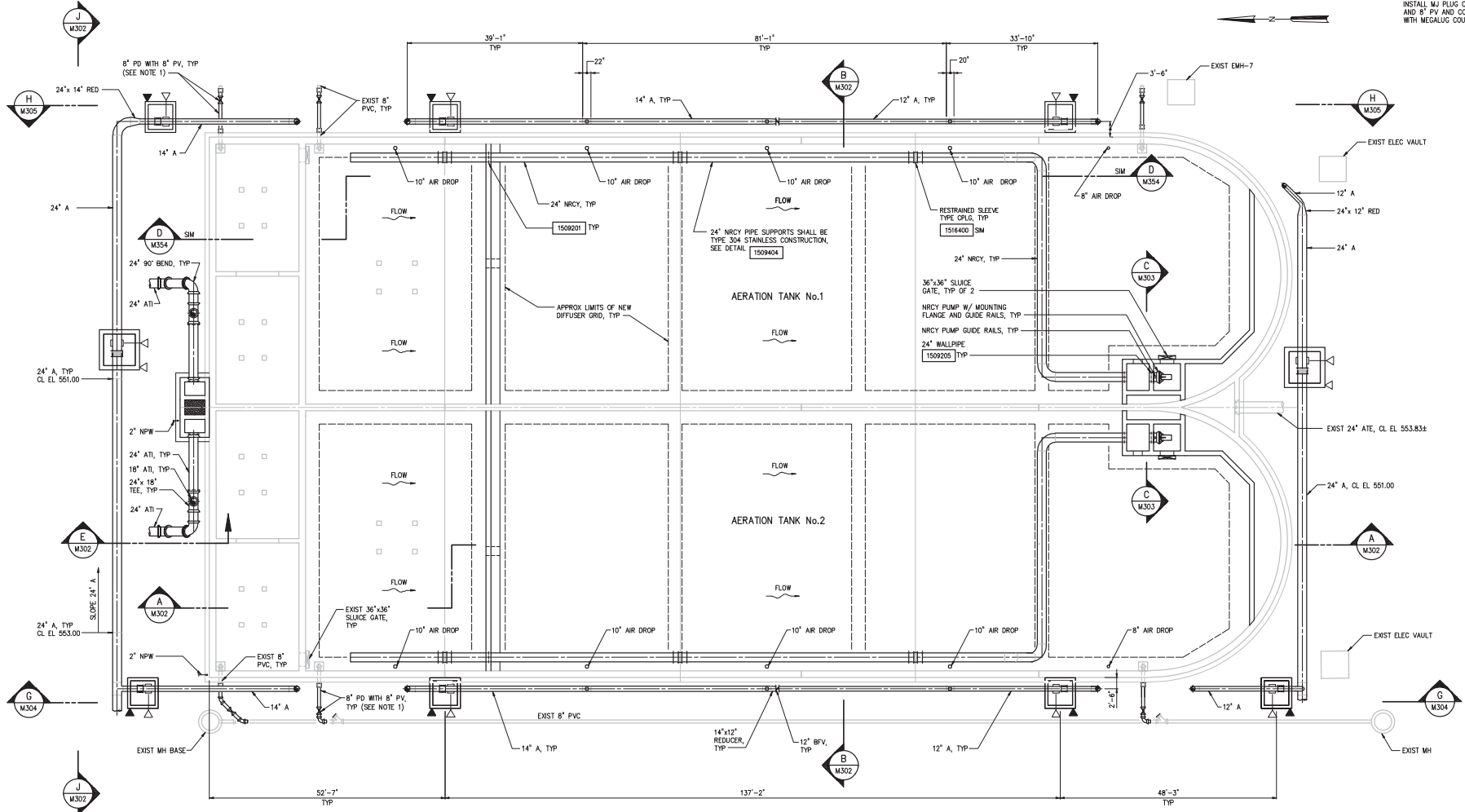

BOTTOM PLAN
3/32" = 1'-0"

NO.	ISSUED FOR	DATE	BY	APPROVED
3	CONSTRUCTION	4/7/16	H.S.	JNS
2	BUILDING CODE ENFORCEMENT	4/7/16	H.S.	JNS
1	REGULATORY APPROVAL	1/7/16	H.S.	JNS

DESIGNED: MDP
 DRAWN: HLF
 CHECKED: MDP
 PROJ. ENGR: JNS

HAZEN AND SAWYER
 4944 PARKWAY PLAZA BLVD., SUITE 375
 CHARLOTTE, NORTH CAROLINA 28217
 LICENSE NO. : C-0381

UNION COUNTY
NORTH CAROLINA

 TWELVE MILE CREEK WWTP
 7.5 mgd EXPANSION

AERATION TANKS NO.1 AND NO.2
 MECHANICAL
 BOTTOM PLAN

THE SCALE BAR SHOWN BELOW MEASURES ONE INCH LONG ON THE ORIGINAL DRAWING.	DATE: APRIL 2016
H & S JOB NUMBER: 30831-045	CONTRACT NUMBER: 1
DRAWING NUMBER: M300	ISSUED FOR CONSTRUCTION

20160403 12:39 P 1509210301 045.dwg (PROJECT) PLOT300.dwg By: JNS Date Saved By: jns Date: 4/7/16 10:56:16 AM 1509210301

ISSUED FOR CONSTRUCTION

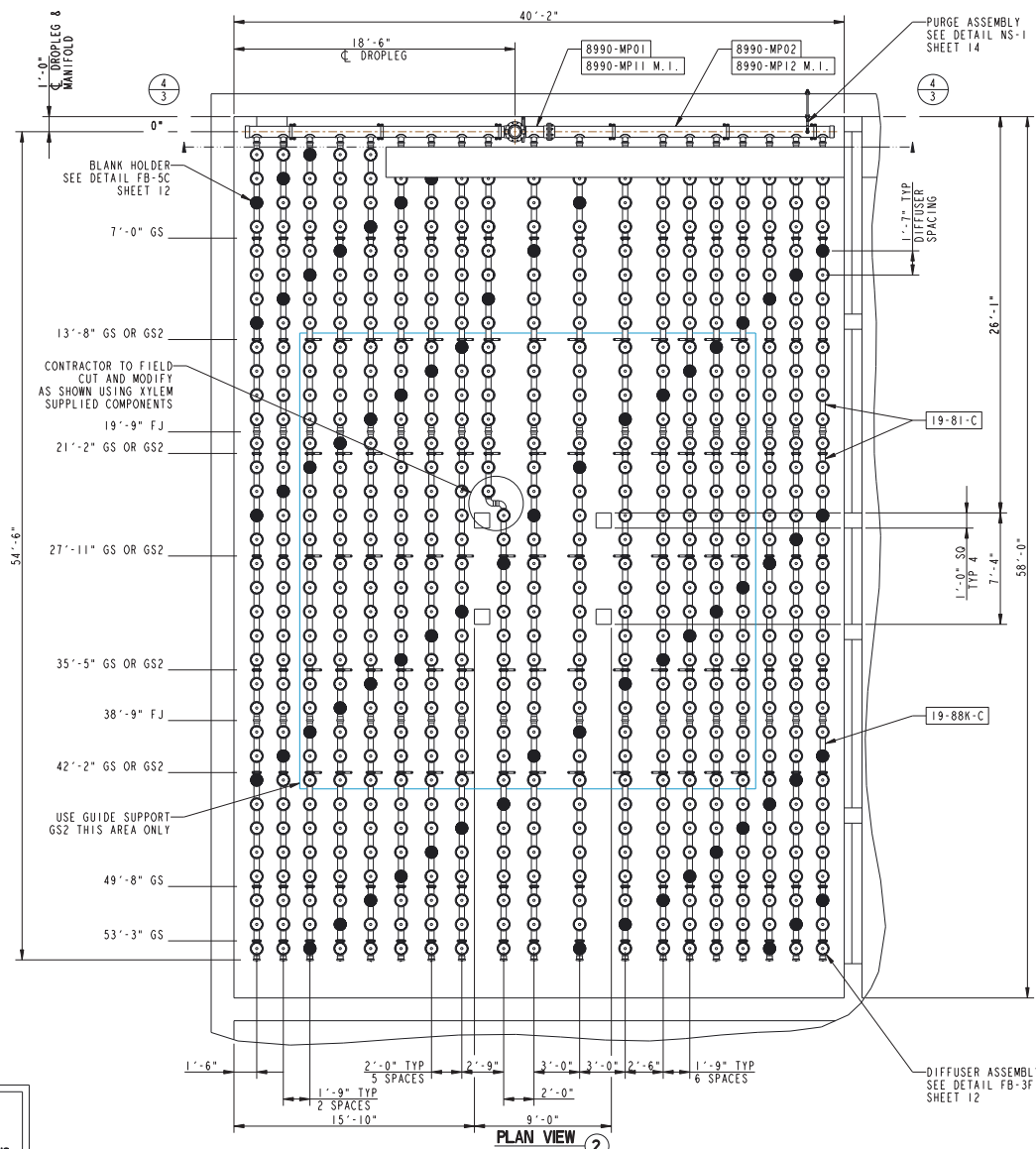

NOTE: SUPPORT SPACING

Every attempt has been made to insure locational dimensions of the supports are correct. However, after one line of air distributor anchors for any grid type have been installed, the locations must be checked for proper clearances by installing the supplied air headers. Spacing between lines must be checked for fit with the cross manifold and drain line. Any discrepancies or interferences must be brought to the attention of XYLEM prior to further installation.

The actual support anchor locations must be indexed from the centerline of the manifold. The actual accumulative dimensional error from the manifold to the anchor bolt must not exceed $\pm 3/4"$.

GRID TYPE A

4-TANK(S)
 1-GRID(S) PER TANK
 19-AIR DISTRIBUTORS PER GRID
 34-DIFFUSER HOLDERS PER DISTRIBUTOR
 VARIES-DIFFUSER ELEMENTS PER DISTRIBUTOR
 646-DIFFUSER HOLDERS PER GRID
 575-DIFFUSER ELEMENTS INSTALLED PER GRID
 2300-TOTAL DIFFUSER ELEMENTS INSTALLED
 FOR THIS GRID TYPE
 71-BLANKS PER GRID

LEGEND

- FJ - FIXED JOINT
SEE DETAIL FB-10A SHEET-12
 - GS - GUIDE SUPPORT
SEE DETAIL SUP-2 SHEET-13
 - GS2 - GUIDE SUPPORT
SEE DETAIL SUP-2A SHEET-13
- | FOR GS & GS2 | | |
|--------------|----------|---------|
| TANK | SUPPORT | STRUT |
| 1 & 2 | 2354-3SP | 1878-48 |
| 5 & 6 | 2354-2SP | 1878-46 |
- FOR TYPICAL AIR DISTRIBUTOR SECTION
SEE DETAIL FB-22K SHEET-12

NOTE:
 PLEASE VERIFY ALL DIMENSIONS AND ELEVATIONS, INCLUDING: INSIDE TANK DIMENSIONS, DROPLEG LOCATIONS, ELEVATIONS OF DROPLEG CONNECTIONS, FACE OF FLANGES, DIFFUSER ELEVATIONS, FLAT FLOOR AND HIGHPOINT/LOWPOINT ELEVATIONS OF SLOPED FLOOR.

GRID TYPE A
 2 REQ'D AS SHOWN (TANK 1 AND 5)
 2 REQ'D MIRROR IMAGE (TANK 2 AND 6)

WARNING
 XYLEM DOES NOT ACCEPT RESPONSIBILITY FOR UNDOCUMENTED CUSTOMER INITIATED CHANGES TO ELECTRONICALLY TRANSMITTED DRAWINGS

REV	DATE	REVISION	BY

UNION COUNTY
 NORTH CAROLINA
 TWELVE MILE CREEK
 WASTEWATER TREATMENT PLANT

THIS DRAWING IS THE PROPERTY OF XYLEM AND IS SUBMITTED IN CONFIDENCE. IT IS NOT TO BE DISCLOSED, USED OR REPLICATED WITHOUT PERMISSION OF XYLEM.

PLAN VIEW
 GRID TYPE A

SANITAIRE
 a xylem brand

Xylem, Inc. 16-89905

DATE BY: J.C. DATE 01/06/17	DATE BY: J.S. DATE 02/01/17	DATE BY: J.S. DATE 02/01/17	DATE BY: J.S. DATE 02/01/17
APP'D BY: J.S. DATE 02/01/17	APP'D BY: J.S. DATE 02/01/17	APP'D BY: J.S. DATE 02/01/17	APP'D BY: J.S. DATE 02/01/17

SHEET 2 OF 4

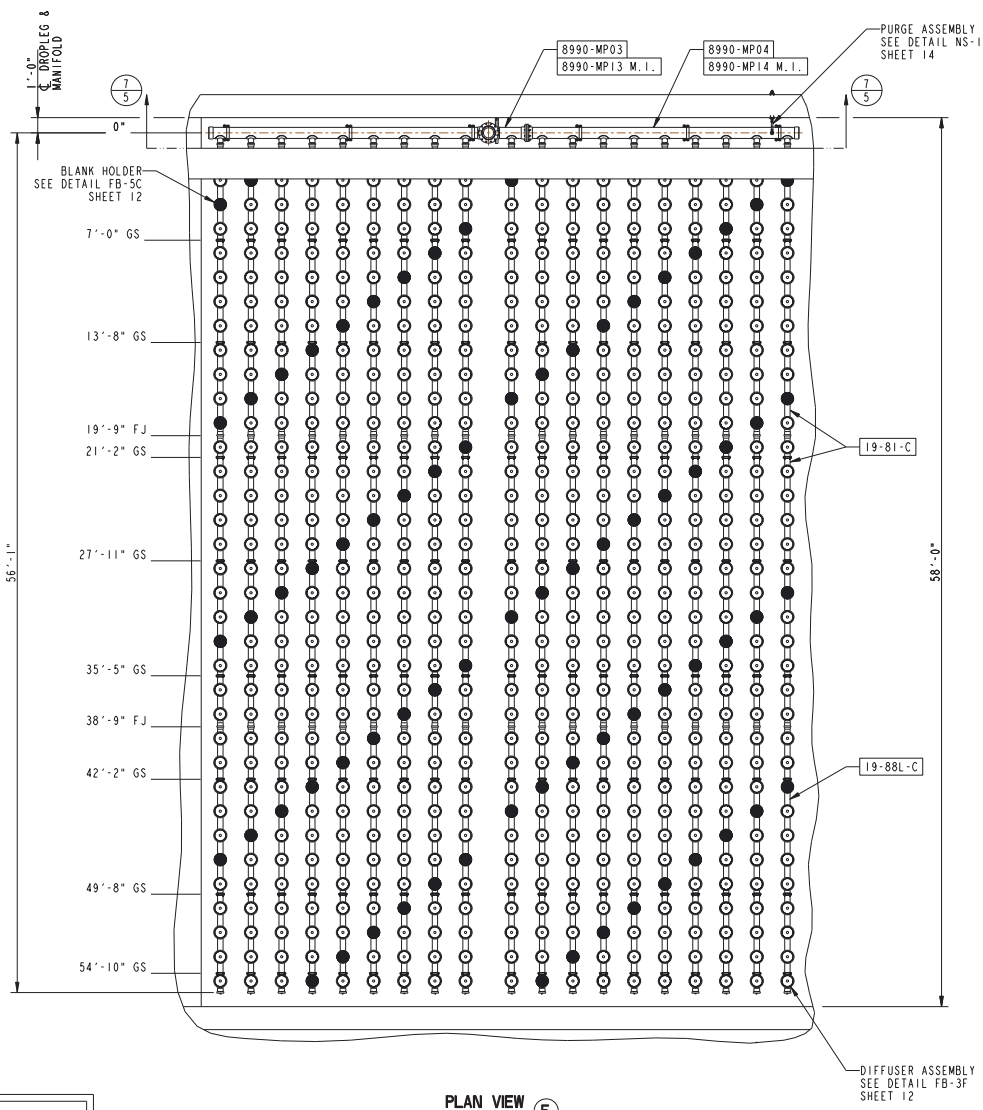

NOTE: SUPPORT SPACING

Every attempt has been made to insure locational dimensions of the supports are correct. However, after one line of air distributor anchors for any grid type have been installed, the locations must be checked for proper clearances by installing the supplied air headers. Spacing between lines must be checked for fit with the cross manifold and drain line. Any discrepancies or interferences must be brought to the attention of XYLEM prior to further installation.

The actual support anchor locations must be indexed from the centerline of the manifold. The actual accumulative dimensional error from the manifold to the anchor bolt must not exceed $\pm 3/4"$.

GRID TYPE B

4-TANK(S)
 1-GRID(S) PER TANK
 19-AIR DISTRIBUTORS PER GRID
 35-DIFFUSER HOLDERS PER DISTRIBUTOR
 VARIES-DIFFUSER ELEMENTS PER DISTRIBUTOR
 665-DIFFUSER HOLDERS PER GRID
 588-DIFFUSER ELEMENTS INSTALLED PER GRID
 2352-TOTAL DIFFUSER ELEMENTS INSTALLED
 FOR THIS GRID TYPE
 77-BLANKS PER GRID

LEGEND

FJ - FIXED JOINT
 SEE DETAIL FB-10A
 SHEET-12

GS - GUIDE SUPPORT
 SEE DETAIL SUP-1
 SHEET-13

FOR GS	
TANK	SUPPORT
1 & 2	2346-3SP
5 & 6	2346-2SP

- FOR TYPICAL AIR DISTRIBUTOR SECTION
 SEE DETAIL FB-22K
 SHEET-12

NOTE:
 PLEASE VERIFY ALL DIMENSIONS AND ELEVATIONS, INCLUDING: INSIDE TANK DIMENSIONS, DROPLEG LOCATIONS, ELEVATIONS OF DROPLEGS CONNECTIONS, FACE OF FLANGES, DIFFUSER CONNECTIONS, FLAT FLOOR AND HIGHPOINT/LOWPOINT ELEVATIONS OF SLOPED FLOOR.

PLAN VIEW 5

GRID TYPE B
 2 REQ'D AS SHOWN (TANK 1 AND 5)
 2 REQ'D MIRROR IMAGE (TANK 2 AND 6)

FOR APPROVAL ONLY.
 NOT FOR CONSTRUCTION.
 xylem
 03/21/17

WARNING
 xylem DOES NOT ACCEPT RESPONSIBILITY FOR UNDOCUMENTED CUSTOMER INITIATED CHANGES TO ELECTRONICALLY TRANSMITTED DRAWINGS

REV	DATE	REVISION	BY

UNION COUNTY
 NORTH CAROLINA
 TWELVE MILE CREEK
 WASTEWATER TREATMENT PLANT

THIS DRAWING IS THE PROPERTY OF XYLEM AND IS SUBMITTED IN CONFIDENCE. IT IS NOT TO BE DISCLOSED, USED OR DUPLICATED WITHOUT PERMISSION OF XYLEM.

PLAN VIEW
 GRID TYPE B

SANITAIRE
 a xylem brand

16-8990S
 4 OF 4

DATE BY: J.C. DANE 01/06/17
 CHECK BY: J.S. DANE 02/01/17
 APPROV BY: J.S. DANE 02/01/17

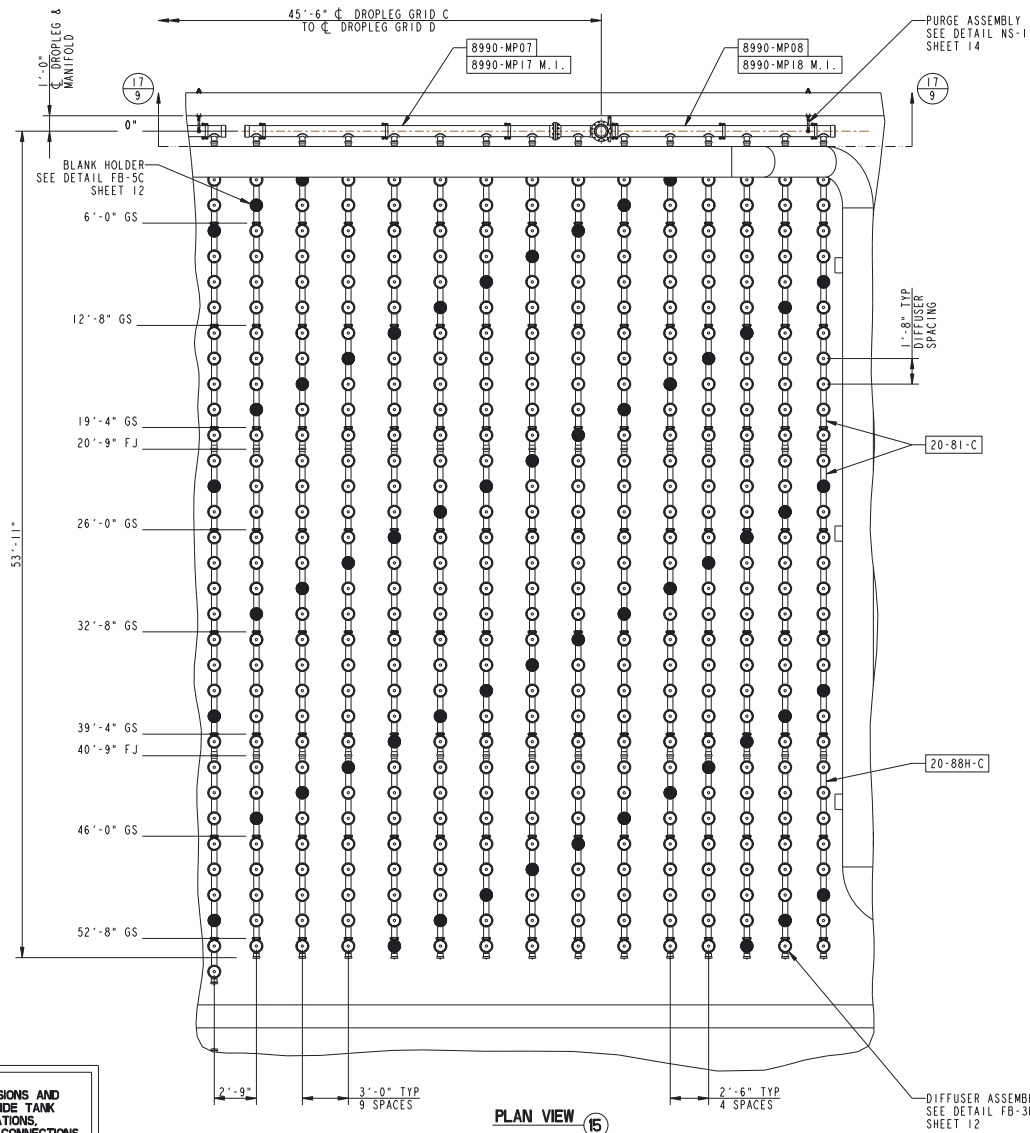

NOTE: SUPPORT SPACING

Every attempt has been made to insure locational dimensions of the supports are correct. However, after one line of air distributor anchors for any grid type have been installed, the locations must be checked for proper clearances by installing the supplied air headers. Spacing between lines must be checked for fit with the cross manifold and drain line. Any discrepancies or interferences must be brought to the attention of XYLEM prior to further installation.

The actual support anchor locations must be indexed from the centerline of the manifold. The actual accumulative dimensional error from the manifold to the anchor bolt must not exceed $\pm 3/4"$.

GRID TYPE D

- 4-TANK(S)
- 1-GRID(S) PER TANK
- 14-AIR DISTRIBUTORS PER GRID
- 32-DIFFUSER HOLDERS PER DISTRIBUTOR
- VARIES-DIFFUSER ELEMENTS PER DISTRIBUTOR
- 448-DIFFUSER HOLDERS PER GRID
- 392-DIFFUSER ELEMENTS INSTALLED PER GRID
- 1568-TOTAL DIFFUSER ELEMENTS INSTALLED
- FOR THIS GRID TYPE
- 56-BLANKS PER GRID

LEGEND

FJ - FIXED JOINT
SEE DETAIL FB-10A
SHEET-12

GS - GUIDE SUPPORT
SEE DETAIL SUP-1
SHEET-13

FOR GS	
TANK	SUPPORT
1 & 2	2346-3SP
5 & 6	2346-2SP

FOR TYPICAL AIR DISTRIBUTOR SECTION
SEE DETAIL FB-22K
SHEET-12

NOTE:
PLEASE VERIFY ALL DIMENSIONS AND ELEVATIONS, INCLUDING INSIDE TANK DIMENSIONS, DROPLEG LOCATIONS, ELEVATIONS OF DROPLEGS CONNECTIONS, FACE OF FLANGES, DIFFUSER ELEVATIONS, FLAT FLOOR AND HIGHPOINT/LOWPOINT ELEVATIONS OF SLOPED FLOOR.

PLAN VIEW 15

GRID TYPE D
2 REQ'D AS SHOWN (TANK 1 AND 5)
2 REQ'D MIRROR IMAGE (TANK 2 AND 6)

DIFFUSER ASSEMBLY
SEE DETAIL FB-3F
SHEET 12

WARNING
XYLEM DOES NOT ACCEPT RESPONSIBILITY FOR UNDOCUMENTED CUSTOMER INITIATED CHANGES TO ELECTRONICALLY TRANSMITTED DRAWINGS

REV	DATE	REVISION	BY

UNION COUNTY
NORTH CAROLINA
TWELVE MILE CREEK
WASTEWATER TREATMENT PLANT

THIS DRAWING IS THE PROPERTY OF XYLEM AND IS SUBMITTED IN CONFIDENCE. IT IS NOT TO BE DISCLOSED, USED OR DUPLICATED WITHOUT PERMISSION OF XYLEM.

PLAN VIEW
GRID TYPE D

SANITAIRE
a xylem brand

DATE BY: J.C. DANE 01/06/17	DATE: 01/06/17	NO: 16-8990S	SHEET: 8
DATE BY: J.S. DANE 02/01/17	DATE: 02/01/17	NO: E-8	OF: 14
DATE BY: J.S. DANE 02/01/17	DATE: 02/01/17	NO: E-8	OF: 14

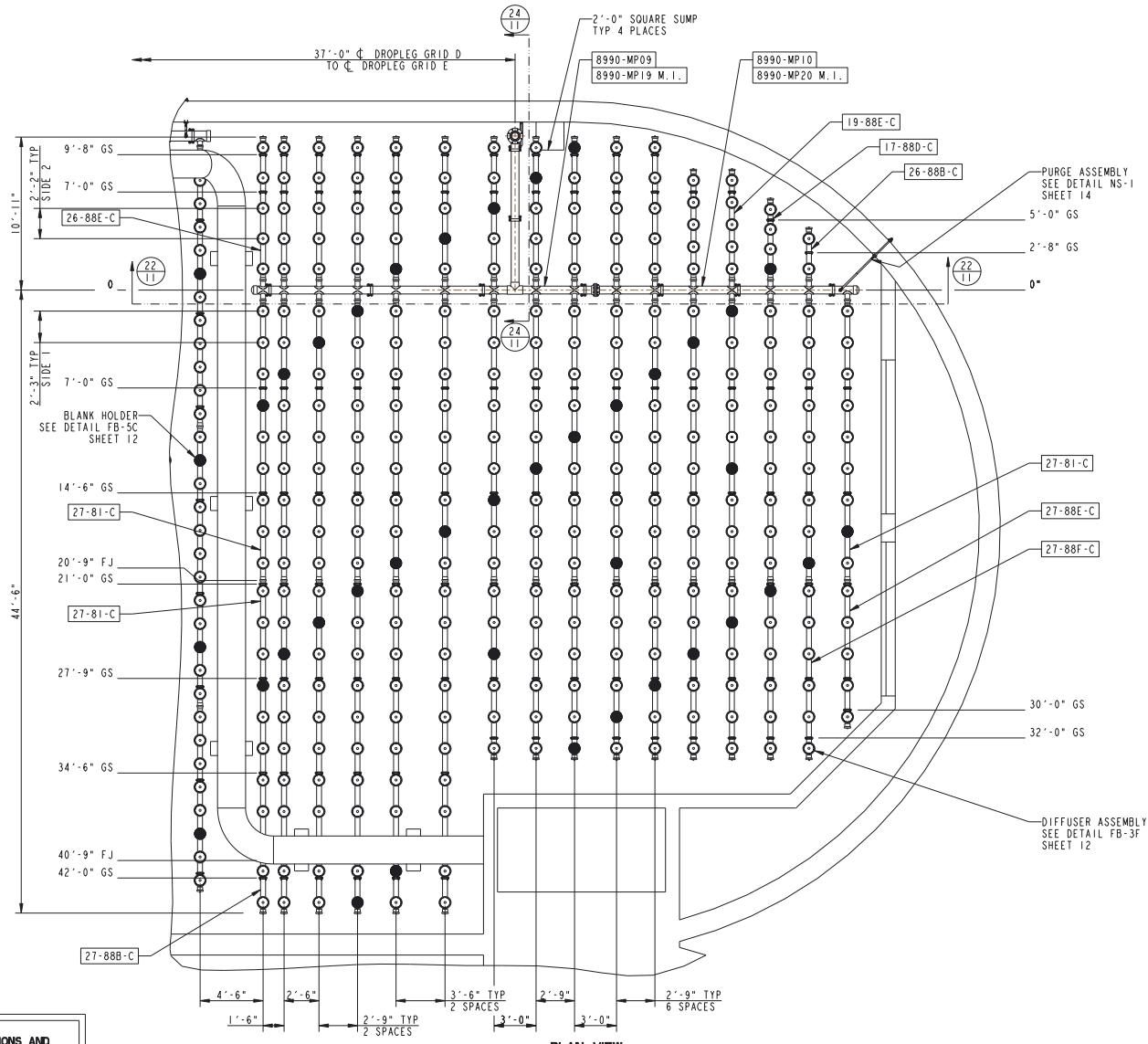

NOTE: SUPPORT SPACING

Every attempt has been made to insure locational dimensions of the supports are correct. However, after one line of air distributor anchors for any grid type have been installed, the locations must be checked for proper clearances by installing the supplied air headers. Spacing between lines must be checked for fit with the cross manifold and drain line. Any discrepancies or interferences must be brought to the attention of XYLEM prior to further installation.

The actual support anchor locations must be inferred from the centerline of the manifold. The actual accumulative dimensional error from the manifold to the anchor bolt must not exceed $\pm 3/4"$.

GRID TYPE E

4-TANK(S)
 1-GRIDS(S) PER TANK
 16-AIR DISTRIBUTORS PER GRID
 VARIES-DIFFUSER HOLDERS PER DISTRIBUTOR
 VARIES-DIFFUSER ELEMENTS PER DISTRIBUTOR
 340-DIFFUSER HOLDERS PER GRID
 303-DIFFUSER ELEMENTS INSTALLED PER GRID
 1212-TOTAL DIFFUSER ELEMENTS INSTALLED
 FOR THIS GRID TYPE
 37-BLANKS PER GRID

LEGEND

FJ - FIXED JOINT
 SEE DETAIL FB-10A
 SHEET-12

GS - GUIDE SUPPORT SEE DETAIL SUP-1 SHEET-13	FOR GS	
	TANK	SUPPORT
	1 & 2	2346-3SP
	5 & 6	2346-2SP

FOR TYPICAL AIR DISTRIBUTOR SECTION
 SEE DETAIL FB-22K
 SHEET-12

NOTE:
 PLEASE VERIFY ALL DIMENSIONS AND ELEVATIONS, INCLUDING INSIDE TANK DIMENSIONS, DROPLEG LOCATIONS, ELEVATIONS OF DROPLEG CONNECTIONS, FACE OF FLANGES, DIFFUSER CONNECTIONS, FLAT FLOOR AND HIGHPOINT/LOWPOINT ELEVATIONS OF SLOPED FLOOR.

PLAN VIEW 20

GRID TYPE E
 2 REQ'D AS SHOWN (TANK 1 AND 5)
 2 REQ'D MIRROR IMAGE (TANK 2 AND 6)

WARNING
 XYLEM DOES NOT ACCEPT RESPONSIBILITY FOR UNDOCUMENTED CUSTOMER INITIATED CHANGES TO ELECTRONICALLY TRANSMITTED DRAWINGS

REV	DATE	REVISION	BY

UNION COUNTY
 NORTH CAROLINA
 TWELVE MILE CREEK
 WASTEWATER TREATMENT PLANT

THIS DRAWING IS THE PROPERTY OF XYLEM AND IS SUBMITTED IN CONFIDENCE. IT IS NOT TO BE DISCLOSED, USED OR REPRODUCED WITHOUT PERMISSION OF XYLEM.

PLAN VIEW
 GRID TYPE E

SANITAIRE
 a xylem brand

XYLEM BRAND, WASTEWATER DIVISION

DATE BY: J.C. DANE 01/06/17	SCALE: 1/8" = 1'-0"	PROJECT: 16-8990S	SHEET: 10
DATE BY: J.S. DANE 02/01/17	SCALE: 1/8" = 1'-0"	PROJECT: 16-8990S	SHEET: 10
DATE BY: J.S. DANE 02/01/17	SCALE: 1/8" = 1'-0"	PROJECT: 16-8990S	SHEET: 10

LEGEND

- ▲ DENOTES FIXED PIPE SUPPORT
- △ DENOTES SLIDING PIPE SUPPORT

NOTES:

1. AERATION TANK NO. 1: TYPICAL THREE (3) LOCATIONS: REMOVE MAX 8'-0" LENGTH OF EXIST 8" DRAIN PIPING INCLUDING EXIST PLUG VALVE. INSTALL NEW 8" PD AND 8" PV AND CONNECT TO EXISTING PIPING WITH MEGALUG COUPLINGS.
2. AERATION TANK NO. 2: TYPICAL THREE (3) LOCATIONS: REMOVE EXIST 8" DRAIN PIPING INCLUDING EXIST PLUG VALVE FROM EDGE OF TANK STRUCTURE TO WYE ON DRAIN HEADER. INSTALL NJ PLUG ON WYE. INSTALL NEW 8" PD AND 8" PV AND CONNECT TO EXISTING PIPING WITH MEGALUG COUPLINGS PER DETAIL 1/M303.

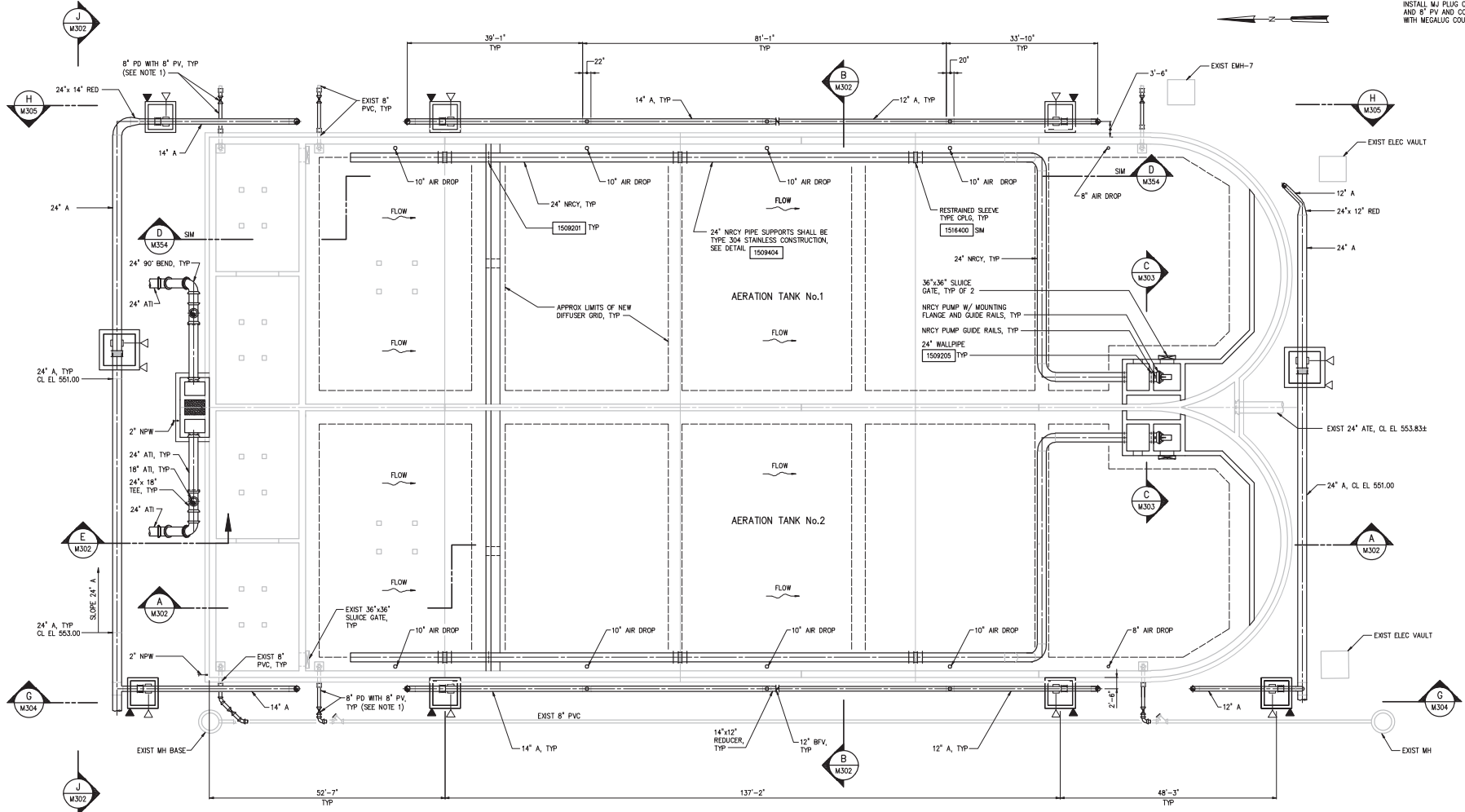

BOTTOM PLAN
3/32" = 1'-0"

NO.	ISSUED FOR	DATE	BY	APPROVED
3	CONSTRUCTION	4/7/16	H.S.	JNS
2	BUILDING CODE ENFORCEMENT	4/7/16	H.S.	JNS
1	REGULATORY APPROVAL	1/7/16	H.S.	JNS

DESIGNED: MDP
 DRAWN: HLF
 CHECKED: MDP
 PROJ. ENGR: JNS

HAZEN AND SAWYER
 4944 PARKWAY PLAZA BLVD., SUITE 375
 CHARLOTTE, NORTH CAROLINA 28217
 LICENSE NO. : C-0381

UNION COUNTY
NORTH CAROLINA

 TWELVE MILE CREEK WWTP
 7.5 mgd EXPANSION

AERATION TANKS NO.1 AND NO.2
 MECHANICAL
 BOTTOM PLAN

THE SCALE BAR SHOWN BELOW MEASURES ONE INCH LONG ON THE ORIGINAL DRAWING.	DATE: APRIL 2016
H & S JOB NUMBER: 30831-045	CONTRACT NUMBER: 1
DRAWING NUMBER: M300	ISSUED FOR CONSTRUCTION

2016/04/03 10:29 AM C:\Users\jns\OneDrive\Projects\30831-045\121716.dwg by JNS:121716.dwg saved by: jns:121716.dwg

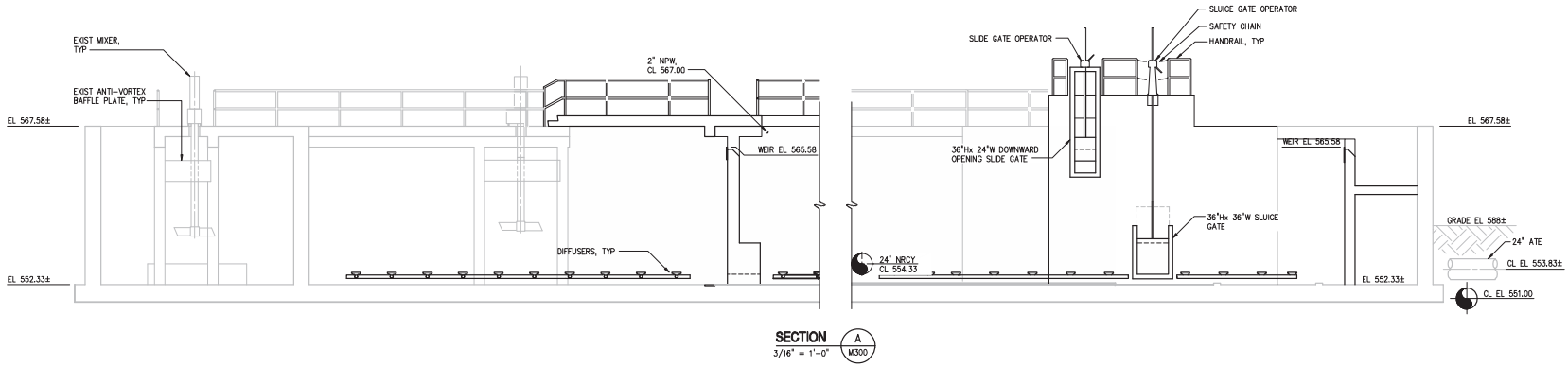

- NOTES:**
1. PIPING SUPPORTS AND EQUIPMENT DOWNSTREAM OF THE BUTTERFLY VALVE SHALL BE SUPPLIED BY THE DIFFUSER MANUFACTURER UNDER SECTION 11439, TYP.
 2. TEMPORARY PIPING TO BE PLACED IN SERVICE TO DEMOLISH EXISTING INFLUENT STRUCTURE AND BUILD NEW INFLUENT STRUCTURE. INSTALL 12" BLIND FLANGE AND RJ PLUG AT TERMINATIONS WHEN TEMPORARY PIPING IS REMOVED.
 3. PROVIDE TEMPORARY PLUG W/ DRAIN TAP SIMILAR TO STD. DETAIL 1511501, REFER TO SECTION 0320 FOR CONSTRUCTION CONSTRAINTS.

SECTION A
3/16" = 1'-0"
M300

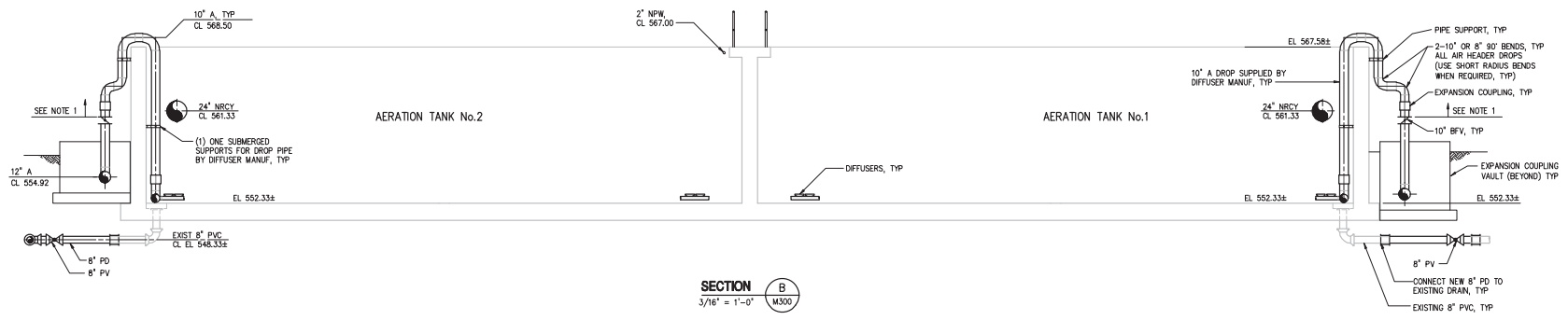

SECTION B
3/16" = 1'-0"
M300

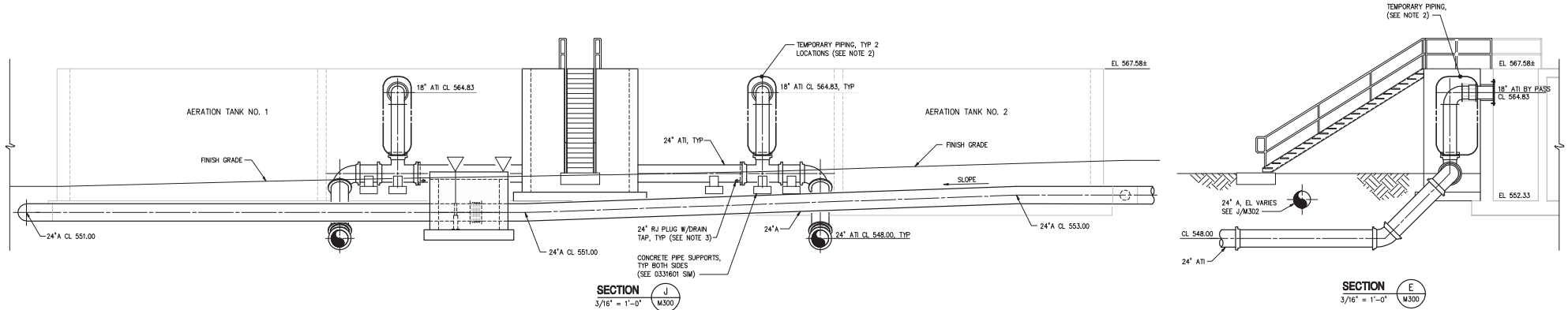

SECTION J
3/16" = 1'-0"
M300

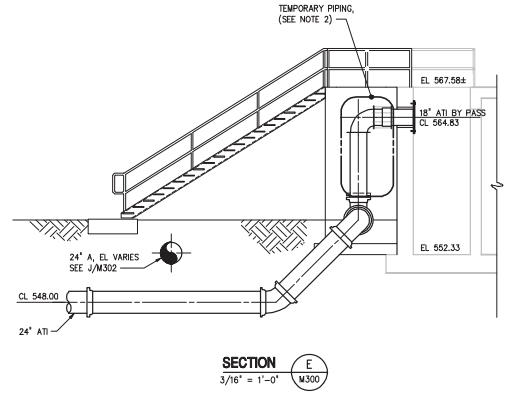

SECTION E
3/16" = 1'-0"
M300

NO.	ISSUED FOR	DATE	BY	APPROVED
3	CONSTRUCTION	4/7/16	H&S	JNS
2	BUILDING CODE ENFORCEMENT	4/7/16	H&S	
1	REGULATORY APPROVAL	1/7/16	H&S	

DESIGNED: MDP
 DRAWN: HLF
 CHECKED: MDP
 PROJ. ENGR: JNS

NORTH CAROLINA
 PROFESSIONAL ENGINEER
 MICHAEL D. PARKER
 LICENSE NO. 28833

Hazen
 HAZEN AND SAWYER
 4944 PARKWAY PLAZA BLVD., SUITE 375
 CHARLOTTE, NORTH CAROLINA 28217
 LICENSE NO. : C-0381

UNION COUNTY
NORTH CAROLINA
 TWELVE MILE CREEK WWTP
 7.5 mgd EXPANSION

AERATION TANKS NO.1 AND NO.2
 MECHANICAL
 SECTIONS

THE SCALE BAR SHOWN BELOW MEASURES ONE INCH LONG ON THE ORIGINAL DRAWING.	DATE: APRIL 2016	H & S JOB NUMBER: 30831-045
	CONTRACT NUMBER: 1	DRAWING NUMBER: M302

2016/04/03 10:29 AM C:\Users\jns\OneDrive\Projects\120212.dwg by JNS/TFM Last Saved by: jns/mcd 12/16/16 10:29 AM 12/16/16 10:29 AM 12/16/16 10:29 AM 12/16/16 10:29 AM 12/16/16 10:29 AM

ISSUED FOR CONSTRUCTION

12 APPENDIX E – SAMPLE VENDOR PAYMENT NOTIFICATION

RFP 2026-044 Aeration Tank Cleaning

Informational Purposes Only - Do not submit with proposal.



Finance Department

500 North Main Street Suite #714
Monroe, NC 28112 T. 704-283-3813
www.unioncountync.gov

ATTENTION: ACCOUNTS PAYABLE VENDORS

As part of our Fraud Prevention Program, Union County now prefers two methods for payments to vendor accounts. These methods allow for faster and easier payments to vendors.

The first and preferred method available is to accept a VISA card payment from the County. If you accept payment via VISA, payment is made at the time of the transaction or upon receipt and approval of the invoice.

The second method is an Electronic Funds Transfer. (EFT) This means that you will receive payment of invoices due directly into your bank account. With this method, you will get an email confirmation giving you the date, invoice numbers, and total amount paid. Your payment will be available to you on Monday (or the first banking day if Monday is a bank holiday) following receipt of an approved invoice from the County department invoiced.

An EFT Enrollment Form to enroll in the program is attached for your convenience. You can also visit the Union County website at www.unioncountync.gov at any time to get a new form if your banking information changes. If the banking information changes and you do not notify us, it will delay receipt of payment for invoices.

If you wish to receive payment via the County's VISA card, please contact Heather Howey at 704-283-3539, or send an email to ap@unioncountync.gov and you will be added to the list of vendors accepting the VISA card method of payment.

Union County prefers all vendors participate in one of the two methods described above.

Thank you in advance for your participation.

13 APPENDIX F – TEMPLATE CONTRACT

RFP 2026-044 Aeration Tank Cleaning

Informational Purposes Only - Do not submit with proposal.

STATE OF NORTH CAROLINA

AGREEMENT

COUNTY OF UNION

THIS AGREEMENT is made and entered into as of _____, by and between UNION COUNTY, a political subdivision of the State of North Carolina, whose address is 500 North Main Street, Monroe, NC 28112, hereinafter “Union,” and [Contractor’s full legal name], a [type of business (corporation, limited liability company, etc.) and state where incorporated], whose address is _____, hereinafter “Contractor.”

W I T N E S S E T H

WHEREAS, Union desires that Contractor perform certain [briefly describe services here] services; and

WHEREAS, Contractor is willing to perform such services as described in this Agreement.

NOW, THEREFORE, in consideration of the mutual covenants and agreements hereinafter set forth, the parties hereto do each contract and agree with the other as follows:

1. **SERVICES PERFORMED.** Contractor agrees to perform the services as set forth in the attached Scope of Work [or, if the full RFP is to be attached as the scope of work, state the RFP number and full RFP title], which is incorporated herein by reference (hereinafter the “Services”), in accordance with the terms of this Agreement.
2. **FEE AND PAYMENT SCHEDULE.** Union shall pay Contractor [insert payment amount or rate] for performance of the Services. Contractor shall invoice Union on a monthly basis for Services performed, or upon such other schedule as may be agreed upon by the parties. Payment is due within thirty (30) days of receipt of an accurate invoice by Union’s Finance Division. All payments shall be conditioned upon appropriation by the Union County Board of Commissioners of sufficient funds for each request for services.
3. **TERM AND TERMINATION.** The Effective Date is the date of mutual execution of this Agreement. This Agreement shall have a term of [insert agreement time length] (the “Initial Term”). [The following sentence to be used only if renewals might be needed or desired, and then only if the RFP lists the possible number of renewals. If the contract is just for a single term, this sentence may be deleted.] Upon completion of the Initial Term, Union may, in its sole discretion, elect to renew this Agreement for up to ___[number of possible additional terms, as stated in the RFP] additional ___[number of years in each renewal term]-year terms, each a “Renewal Term,” upon written notice to the Contractor. Union may terminate this Agreement at any time, without cause, upon provision of ten (10) days’ written notice to Contractor. In the event of termination without cause, Contractor shall be paid for services performed to the date of notification of termination by Union.
4. **OWNERSHIP OF DOCUMENTS.** All deliverables and any other contract documents prepared by Contractor, or any subcontractors or subconsultants under the terms of this Agreement (“the Documents”), shall be the property of Union. Contractor further acknowledges that Union is subject to Chapter 132 of the North Carolina General Statutes, the Public Records Act (the

“Act”), and that this Agreement, as well as any of the Documents as defined herein, shall be a public record as defined in such Act, and as such, will be open to public disclosure and copying.

5. INSURANCE. The attached Exhibit A, Insurance Requirements, is incorporated herein by reference.

6. INDEMNIFICATION. Contractor agrees to protect, defend, indemnify and hold Union, its officers, employees and agents free and harmless from and against any and all losses, penalties, damages, settlements, costs, charges, professional fees or other expenses or liabilities of every kind and character arising out of or relating to any and all claims, liens, demands, obligations, actions, proceedings, or causes of action of every kind in connection with or arising out of this Agreement and/or the performance hereof that are due, in whole or in part, to the negligence of Contractor, its officers, employees, subcontractors or agents. Contractor further agrees to investigate, handle, respond to, provide defense for, and defend the same at its sole expense and agrees to bear all other costs and expenses related thereto.

7. DECLARATION BY CONTRACTOR. Contractor declares that Contractor has complied with all federal, state and local laws regarding business permits, certificates, and licenses that may be required to carry out the work to be performed under this Agreement.

8. FEDERAL, STATE, AND LOCAL TAXES. Neither federal, nor state, nor local income tax nor payroll tax of any kind shall be withheld or paid by Union on behalf of Contractor or the employees of Contractor. Contractor shall not be treated as an employee with respect to the services performed hereunder for federal or state tax purposes.

9. NOTICE TO CONTRACTOR REGARDING ITS TAX DUTIES AND LIABILITIES. Contractor understands that Contractor is responsible to pay, according to law, Contractor’s income tax. If Contractor is not a corporation, Contractor further understands that Contractor may be liable for self-employment (social security) tax, to be paid by Contractor according to law.

10. FRINGE BENEFITS. Because Contractor is engaged in Contractor’s own independently established business, Contractor is not eligible for, and shall not participate in, any employee pension, health or other fringe benefit plan of Union.

11. UNION NOT RESPONSIBLE FOR WORKERS’ COMPENSATION. No workers’ compensation insurance shall be obtained by Union concerning Contractor or the employees of Contractor. Contractor shall comply with the workers’ compensation law concerning Contractor and the employees of Contractor.

12. NO AUTHORITY TO BIND UNION. Contractor has no authority to enter into contracts or agreements on behalf of Union. This Agreement does not create a partnership or any form of agency between the parties.

13. ASSIGNMENT. Neither Union nor Contractor shall assign, sublet or transfer any rights under or interest in this Agreement (including, but without limitation, monies that may become due or monies that are due) without the written consent of the other, except to the extent that any assignment, subletting or transfer is mandated by law or the effect of this limitation may be restricted by law. Unless specifically stated to the contrary in any written consent to assignment, no

assignment shall release or discharge the assignor from any duty or responsibility under this Agreement.

14. NON-WAIVER. The failure of either party to exercise any of its rights under this agreement for a breach thereof shall not be deemed to be a waiver of such rights or a waiver of any subsequent breach.

15. HOW NOTICES SHALL BE GIVEN. Any notice given in connection with this agreement shall be given in writing and shall be delivered either by hand to the party or by certified mail, return receipt requested, to the party at the party's address stated herein. Any party may change its address stated herein by giving notice of the change in accordance with this paragraph.

16. APPLICABLE LAW AND JURISDICTION. This Agreement shall be construed and enforced in accordance with the laws of the State of North Carolina. The parties to this Agreement confer exclusive jurisdiction of all disputes arising hereunder upon the General Courts of Justice of Union County, North Carolina.

17. COMPLETE AGREEMENT. This Agreement contains the complete agreement of the parties regarding the terms and conditions of the Agreement, and there are no oral or written conditions, terms, warranties, understandings or other agreements pertaining thereto which have not been incorporated herein. This Agreement may be modified only by written instrument duly executed by both parties, or their respective successors in interest.

18. SEVERABILITY. The provisions hereof are severable, and should any provision be determined to be invalid, unlawful or otherwise null and void by any court of competent jurisdiction, the other provisions shall remain in full force and effect and shall not thereby be affected unless such ruling shall make further performance hereunder impossible or impose an unconscionable burden upon one of the parties.

19. AUTHORITY. Each party warrants that it has the corporate or other organizational power and authority to execute, deliver and perform this Agreement. Each party further warrants that the execution, delivery and performance by it of the Agreement has been duly authorized and approved by all requisite action of the party's management and appropriate governing body.

20. E-VERIFY. E-Verify is the federal program operated by the United States Department of Homeland Security and other federal agencies, or any successor or equivalent program, used to verify the work authorization of newly hired employees pursuant to federal law. Contractor shall ensure that Contractor and any subcontractor performing work under this Agreement: (i) uses E-Verify if required to do so by North Carolina law; and (ii) otherwise complies with the requirements of Article 2 of Chapter 64 of the North Carolina General Statutes. A breach of this provision by Contractor will be considered a breach of this Agreement, which entitles Union to terminate this Agreement, without penalty, upon notice to Contractor.

[Signatures follow on the next page.]

IN WITNESS WHEREOF, the parties hereto, acting under authority of their respective governing bodies, have hereunto set their hands and seals, and have caused this Agreement to be duly executed, this the day and year first above written.

UNION COUNTY

By: _____ (SEAL)
Brian W. Matthews, County Manager

[CONTRACTOR'S FULL LEGAL NAME]

By: _____ (SEAL)

Approved as to Legal Form _____

This instrument has been preaudited in the manner required by The Local Government Budget and Fiscal Control Act.

Deputy Finance Officer

Exhibit A
Insurance Requirements

I. BASIC INSURANCE REQUIREMENTS. At Contractor's sole expense, Contractor shall procure and maintain the following minimum insurances with insurers authorized to do business in North Carolina and rated A-VII or better by A.M. Best, or as otherwise authorized by the Union County Risk Manager.

A. **WORKERS' COMPENSATION**
Statutory (coverage for three or more employees) limits covering all employees, including Employer's Liability with limits of:

\$500,000	Each Accident
\$500,000	Disease - Each Employee
\$500,000	Disease - Policy Limit

B. **COMMERCIAL GENERAL LIABILITY**
Covering all operations involved in this Agreement.

\$2,000,000	General Aggregate
\$2,000,000	Products/Completed Operations Aggregate
\$1,000,000	Each Occurrence
\$1,000,000	Personal and Advertising Injury Limit

C. **COMMERCIAL AUTOMOBILE LIABILITY**

\$1,000,000	Combined Single Limit - Any Auto
-------------	----------------------------------

D. **PROFESSIONAL LIABILITY**

\$1,000,000	Claims Made
-------------	-------------

Contractor shall provide evidence of continuation or renewal of Professional Liability Insurance for a period of two (2) years following termination of the Agreement.

E. **POLLUTION LIABILITY INSURANCE**

\$1,000,000	Claims Made
-------------	-------------

Contractor shall provide evidence of continuation or renewal of Pollution Liability Insurance for a period of two (2) years following termination of the Agreement.

F. NETWORK SECURITY & PRIVACY LIABILITY (CYBER)

\$1,000,000 Claims Made
\$3,000,000 Aggregate Limit

Contractor shall provide evidence of continuation or renewal of Network Security & Privacy Liability Insurance for a period of two (2) years following termination of the Agreement.

II. **ADDITIONAL INSURANCE REQUIREMENTS.**

A. The Contractor's General Liability policy shall be endorsed, specifically or generally, to include the following as Additional Insured:

UNION COUNTY, ITS OFFICERS, AGENTS AND EMPLOYEES ARE INCLUDED AS ADDITIONAL INSURED WITH RESPECT TO THE GENERAL LIABILITY INSURANCE POLICY.

B. Before commencement of any work or event, Contractor shall provide a Certificate of Insurance in satisfactory form as evidence of the insurances required above.

C. Contractor shall have no right of recovery or subrogation against Union County (including its officers, agents and employees).

D. It is the intention of the parties that the insurance policies afforded by Contractor shall protect both parties and be primary and non-contributory coverage for any and all losses covered by the above-described insurance.

E. Union County shall have no liability with respect to Contractor's personal property whether insured or not insured. Any deductible or self-insured retention is the sole responsibility of Contractor.

F. Notwithstanding the notification requirements of the Insurer, Contractor hereby agrees to notify County's Risk Manager at 500 North Main Street, Monroe, NC 28112, within two (2) days of the cancellation or substantive change of any insurance policy set out herein. Union, in its sole discretion, may deem failure to provide such notice as a breach of this Agreement.

G. The Certificate of Insurance should note in the Description of Operations the following:

Department: _____
Contract #: _____

H. Insurance procured by Contractor shall not reduce nor limit Contractor's contractual obligation to indemnify, save harmless and defend Union County for claims made or suits brought which result from or are in connection with the performance of this Agreement.

I. Certificate Holder shall be listed as follows:

Union County
Attention: Risk Manager
500 North Main Street
Monroe, NC 28112

J. If Contractor is authorized to assign or subcontract any of its rights or duties hereunder and in fact does so, Contractor shall ensure that the assignee or subcontractor satisfies all requirements of this Agreement, including, but not limited to, maintenance of the required insurances coverage and provision of certificate(s) of insurance and additional insured endorsement(s), in proper form prior to commencement of services.

14 APPENDIX G – STORMWATER MAP

RFP 2026-044 Aeration Tank Cleaning

Informational Purposes Only - Do not submit with proposal.

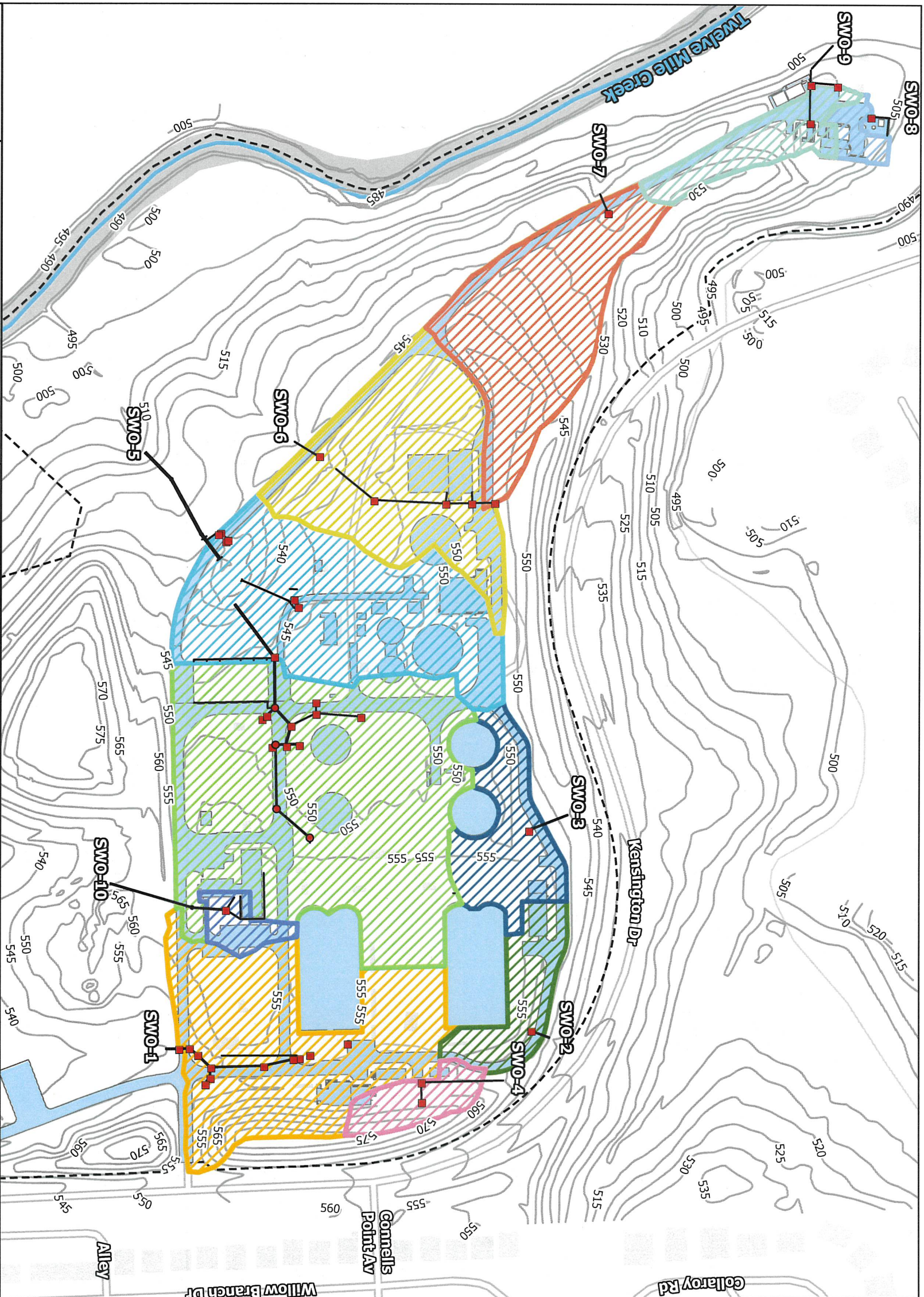

Drainage Basin	Area (acres)	Impervious Area (acres)	Impervious Area (%)	SWO	SWO Lat.	SWO Long.
A	3.453793	0.77897498	22.5541883	1	34.954034486N	-80.762906671
B	0.301058	0.16728186	55.56466233	10	34.953988250N	-80.762549899
C	6.144754	1.61337303	26.25610456	5	34.952810552N	-80.762762588
D	3.557689	1.01072952	28.40988084	5	34.954212461N	-80.762762588
E	0.487565	0.04312675	8.845334215	4	34.950890249N	-80.765068830
F	3.029322	0.86727432	28.62932116	6	34.950830593N	-80.763721730
G	1.125074	0.23608664	20.9840992	3	34.949528011N	-80.765477961
H	0.815404	0.2903732	35.61096061	2	34.949124329N	-80.765360943
I	2.621644	0.32822983	12.52000022	7	34.948742672N	-80.76676013
J	0.737967	0.32402983	43.90844444	9	34.953158909N	-80.767162441
K	0.214971	0.12629476	58.74967457	8	34.954034486N	-80.767565745

Note: SWO-2 and SWO-4 being petitioned to be representative via SWO-2.

LEGEND

- Manholes
- Inlets
- Stormwater Pipe
- Major Topography
- Impervious Surface
- Property Boundary

Drainage Areas

- SWO-1
- SWO-2
- SWO-3
- SWO-4
- SWO-5
- SWO-5
- SWO-6
- SWO-7
- SWO-8
- SWO-9
- SWO-10

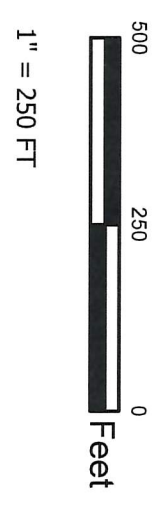

Hazen
 9101 SOUTHERN PINE BOULEVARD, SUITE 250
 CHARLOTTE, NC 28273



UNION COUNTY
 PUBLIC WORKS
 TWELVE MILE CREEK
 WATER RECLAMATION FACILITY

DRAINAGE AREA MAP

DATE: SEPTEMBER 2024

DRAWN BY: A. GRAY

CHECKED BY: C. MCNICOL

ATTACHMENT D