



Raleigh

City of Raleigh

Parks, Recreation and Cultural Resources

Request for Informal Bid

Request for Quote: Construction Services
Project: 2026-Walnut Creek Athletic Complex-Batting Cage Installation
Address: 1201 Sunnybrook Road, Raleigh NC, 27610
Project Manager: Jeff Bryant
Phone #: 919-398-0137
Project #: **274-PRCR-2026-Batting Cage**
Bid Advertise: **Friday May 8, 2026**
Pre-Bid Meeting: **Thursday May 14, 2026, 9:30 am, on-site**
Questions Due By: **Monday May 18, 2026, 3:30 pm**
Bid Due Date: **Tuesday May 26, 2026 @ 3:30 pm, emailed, mailed, or hand delivered per instructions below**

City of Raleigh Parks, Recreation and Cultural Resources Department

Attn: Jeff Bryant

Email: jeffrey.bryant@raleighnc.gov

Mail or Hand Deliver M-F, 7:30 AM - 3:00 PM to:
City of Raleigh Parks Maintenance Office
4225 Daly Road
Raleigh, NC 27604

Plan and specifications are part of these documents

General Description of the Project:

The City of Raleigh (COR) Parks, Recreation and Cultural Resources Department is soliciting bids for the following service: Installation of Dual Lane Outdoor Batting Cage

Pages PF-1 to PF-11 and MWBE pages (Acknowledgement of COR MWBE Policy, Identification of MWBE Participants for Informal Projects) must be completed and emailed before bid due date and time. Email to jeffrey.bryant@raleighnc.gov



Proposal form for the 2026-Walnut Creek Athletic Complex-Batting Cage Installation in the City of Raleigh, North Carolina.

City of Raleigh
Parks, Recreation and Cultural Resources Department
Post Office Box 590
Raleigh, NC 27602

Date: _____

The undersigned bidder has carefully examined the Form of Contract, the Form of Contract Bonds, the General Conditions, the Supplemental and/or Special Conditions, the Plans and Specifications, all of which are acknowledged to be part of the proposal and the Proposal Form, and the Bidder has also carefully examined the site of the proposed work. The undersigned further agrees to sign a Contract for all, or part of the work determined based upon the below amount, if offered within ninety (90) days after receipt of quote, and to furnish surety. The Contractor further agrees to provide and furnish all necessary materials, equipment, machinery, and labor necessary to complete the construction of the work in full, in complete accordance with the plans and specifications and the contract documents to the full and entire satisfaction of the City of Raleigh and in accordance with these documents within the time limit specified below.

In addition to all other agreements and assurances, the undersigned Contractor understands and hereby agrees as follows:

1. If this contract is awarded to the Contractor, they must, upon completion of this contract, or at any other time requested, furnish to the Director of the Department of Parks, Recreation and Cultural Resources an accurate itemized statement of North Carolina Sales Taxes paid on materials, supplies, equipment and any other items charged to this contract, and otherwise fully comply with the Procedure for Reporting North Carolina Sales Tax Expenditures, attached.
2. The Contractor represents and agrees to complete the entire project in the following number of Consecutive Calendar Days: 60 days from Notice to Proceed (NTP)
3. The Contractor agrees to comply with the City Code Raleigh's Standard Procedure regarding the Minority and Women-owned Business Enterprise Program.

In addition, the Contractor agrees to execute the work described and set forth in the Plans and Specifications for the amounts as follows:

2026-Walnut Creek Athletic Complex-Batting Cage Installation

Includes: The primary purpose of this project is to install a dual lane batting cage at Walnut Creek Athletic Complex. Batting cage package to be installed per manufacturer's specifications. Installation and construction to be as per scope of work attached to this bid document.

For Base Bid, contractor to perform work as detailed in scope of work. Installation of pre-purchased batting cage package and installation of new concrete slab. Batting cage materials are on site.

Base Bid Total: _____
(In written word)

\$ _____

Alternate # 1 – Installation of synthetic fabric on concrete surface

Alternate # 1, Total: _____

(in written word)

\$ _____

(in numerals)

Alternate # 2 – Installation of ADA sidewalk connector from Field 9 to front of batting cage area

Alternate # 2, Total (Unit Price Per Square Foot) _____

(in written word)

\$ _____

(in numerals)

Name of General Contractor and License Number _____

Mailing address: _____

Contractor contact phone number: _____ **Email:** _____

GS143-128(d) requires all single prime bidders to identify their subcontractors for the above subdivisions of work. A contractor whose bid is accepted shall not substitute any person as subcontractor in the place of the subcontractor listed in the original bid, except (i) if the listed subcontractor's bid is later determined by the contractor to be non responsible or non-responsive or the listed subcontractor refuses to enter into a contract for the complete

Name of Sub-Contractors and License Number _____

Name of Sub-Contractors and License Number _____

Pursuant to General Statutes of North Carolina Section 143-128 and 143-131 and to City policy, the City of Raleigh encourages and provides equal opportunity for Certified Minority and Woman-Owned Business Enterprise (MWBE) businesses to participate in all aspects of the City's contracting and procurement programs to include - Professional Services; Goods and Other Services; and Construction. The prime contractor will be required to identify participation of MWBE businesses in their proposal, and how that participation will be achieved.

Furthermore, the City's goal is to contract or sub-contract fifteen percent (15%) of the contract amount to Certified MWBEs on construction projects over \$300,000, or with contracts that include \$100,000 or more in state funding (Note this project has no state funding). The goal breakdown is 8% for minorities and 7% for non-minority females. For more information or questions about the MWBE policy, please contact the City's Business Assistance Program coordinator at 919-996-4271. Execute fully the nondiscrimination clause and appropriate affidavits.

ACKNOWLEDGMENT OF RECEIPT OF ADDENDA

The undersigned Bidder hereby acknowledges receipt of the following Addenda:

Addendum Number

Dated

Acknowledge Receipt (initial)

No addenda were received:

Acknowledged for: _____

(Name of Bidder)

By: _____

(Signature of Authorized Representative)

Name: _____

(Print or Type)

Title: _____

Date: _____

PROPOSAL SIGNATURE PAGE

Respectfully submitted this day of _____

By: _____
(Name of firm or corporation making bid)

WITNESS: _____
(Proprietorship or Partnership) ☐

By: _____
Signature
Name: _____
Print or type
Title _____
(Owner/Partner/Pres./V. Pres)
Address _____

ATTEST:
By: _____
Title _____
(Corp. Sec. or Asst. Sec. only)

License No. _____
Federal I.D. No. _____
Email Address: _____

(CORPORATE SEAL)

QUALIFICATIONS

List three references with contact person and telephone number who are qualified to objectively judge the results of similar work performed by the bidder in the last five years.

1. _____

Name and Title

Telephone Number

Project Title/Description

Date of Completion

2. _____

Name and Title

Telephone Number

Project Title/Description

Date of Completion

3. _____

Name and Title

Telephone Number

Project Title/Description

Date of Completion

ADDITIONAL BIDDER'S CERTIFICATION

Acceptance of Terms:

In submitting this Proposal, the undersigned agrees that this Bid will remain in effect for a period of ninety (90) days following the opening of the Bids, that the undersigned agrees to enter into a Contract with the Owner, if awarded, on the basis of this Proposal, and that the undersigned agrees to complete the work in accordance with the Contract Documents

Non-Collusion in Bidding:

The Bidder specifically agrees to abide by all applicable provisions of Article 3 of Chapter 133 of the North Carolina General Statutes. By submission of this Bid, each Bidder and each person signing on behalf of any Bidder certifies, and in case of a joint Bid each party thereto certifies as to its own organization, under penalty of perjury, that to the best knowledge and belief:

1. The prices in this Bid have been arrived at independently without collusion, consultation, communication, or agreement, for the purpose of restricting competition, as to any matter relating to such prices with any other Bidder or to any competitor.
2. Unless otherwise required by law, the prices quoted in the Bid have not been knowingly disclosed by the Bidder and will not knowingly be disclosed by the Bidder prior to opening, directly or indirectly, to any other Bidder or to any competitor; and
3. No attempt has been made or will be made by the Bidder to induce any other person, partnership, or corporation to submit or not to submit a Bid for the purpose of restricting competition.

Type of Business:

The undersigned hereby represents that it is a _____
(corporation, partnership, or an individual)

If a corporation, the undersigned further represents that it is duly qualified as a corporation under the Laws of the State of North Carolina and it is authorized to do business in this State.

Firm Name

Date

Authorized Signature

Title

Name of Project

Address of Business

A RESOLUTION TO REGULATE THE PARTICIPATION IN THE CITY CONSTRUCTION PROJECTS BY CONTRACTORS WHO MAY NOT BE CAPABLE OF TIMELY AND PROPER COMPLETION OF CITY PROJECTS.

WHEREAS, The City of Raleigh wishes to minimize cost and inconvenience to the citizenry caused by the failure of contractors to complete projects in a timely manner in accordance with approved project schedules; and Whereas, North Carolina law allows cities to award bids to responsible bidders and the inability to complete work on time is one indication of a lack of responsibility.

NOW, THEREFORE, BE IT RESOLVED BY THE CITY COUNCIL OF THE CITY OF RALEIGH:

Section 1. That the City Manager may disqualify bidders from participation in bidding and award of contracts for city construction projects based on the following conditions existing simultaneously:

A. The dollar value of the work completed is less than the dollar value of the work which should have been completed on the basis of the contractor's approved progress schedule by more than twenty percent of the current contract amount. The dollar amount of the work completed will be the total estimate to date shown in the latest partial pay estimate. The current contract amount will be the contract estimate plus accumulated overruns and less accumulated underruns shown in the latest partial payment estimate.

B. The percentage of the work completed is less than the percentage of contract time elapsed on the work by more than twenty percent. The percentage of work completed will be the dollar value of the work completed as defined above divided by the current contract amount as defined above. The percentage of contract time elapsed will be the number of calendar days elapsed as shown in the latest partial pay estimate divided by the total contract time in calendar days.

Section 2. The City Manager shall not include any late days, which are caused by the City in any of his calculations directed at determining bid status.

Section 3. All City construction project specifications shall contain a specific provision clearly outlining the policies set in this Resolution, including the criteria for determining whether a contractor is behind schedule, and the specifications shall clearly state the City's intent to enforce the provisions of this Resolution.

Section 4. The terms of the Resolution shall apply only to contracts for which the specifications for bidders are issued after the effective date of this Resolution.

Section 5. Any contractor who wishes to contest the decision of the City Manager declaring ineligibility may appeal to the City Council by delivering a notice of appeal to the City Clerk no later than ten days after receipt of the City Manager's decision. The notice of appeal shall clearly set out the reasons why the Contractor believes that the terms of this Resolution have been inappropriately applied or the equitable arguments for not applying this Resolution's terms. When considering an appeal the City Council shall consider, among other things, the report of the City Manager, the notice of appeal, and the contractor's current status on any other current City Contracts and its performance on any contracts to which the contractor and the City have been parties to within the two calendar years immediately preceding the filing of the notice of appeal.

Section 6. Bidders so disqualified shall remain disqualified for any period in which they are still in conflict with the schedule provisions of this section.

Section 7. This Resolution is effective upon adoption Adopted 10/6/92

SIGNATURE

DATE

PRINTED NAME

TITLE

WORKER'S COMPENSATION INDEMNITY AGREEMENT

_____ is a _____ which seeks to contract as an independent contractor with the City on a project.

_____ has fewer than three employees, and therefore has told the City of Raleigh that it is not required to and does not carry workers' compensation coverage. The City requires that its independent contractors carry workers' compensation coverage. Rather than obtaining coverage in order to contract with the City,

_____ agrees to indemnify and hold the City harmless from any and all claims, damages, losses, or expenses (including attorney's fees) that may be asserted against the City of Raleigh that otherwise might have been covered by workers' compensation insurance.

_____ hereby covenants not to sue the City of Raleigh and not to assert a claim against the City for any matter that otherwise might have been covered by workers' compensation insurance.

This provision is a part of and integral to the contract for

(Type name here)

(Signature)

(Date)

Sworn to and subscribed before me this the _____ day of _____, 20__.

Notary Public

My commission expires:



Minority and Women-Owned Business Enterprise Program (MWBE) Forms

BID FORMS	
DOCUMENT	SUBMISSION REQUIREMENTS
<i>For construction and repair projects that are less than \$300,000 provide the following:</i>	
<ul style="list-style-type: none"> Acknowledgment of City MWBE Policy Identification for MWBE Participation for Informal Project Bids Form 	Due with Bid
<i>For construction and repair projects of \$300,000 or more or for projects that are \$100,000 or more that include any State funding provide the following:</i>	
Acknowledgment of City MWBE Policy	Due with Bid
Identification of MWBE Participation <ul style="list-style-type: none"> List all MWBE firms intended to be used 	Due with Bid Complete Applicable Form: Formal, Informal, Professional
Affidavit A <i>Listing of Good Faith Efforts (GFE)</i> <ul style="list-style-type: none"> Earn at least 50 points 	Due with Bid (If self-performing, submit Affidavit B instead)
Affidavit B <i>Intent to Perform Contract with Own Workforce</i> <ul style="list-style-type: none"> Use only if you are self-performing 100% 	Due with Bid <ul style="list-style-type: none"> If using any subs or suppliers submit Affidavit A instead Affidavits C and D not required
Letter of Intent <ul style="list-style-type: none"> Bidder must submit a separate Letter of Intent for each MWBE subcontractor listed on Affidavit C or Affidavit D. 	Due within 3 business days of notice of being apparent LRRB.
Affidavit C <i>MWBE Subcontractor Utilization Commitment</i> <ul style="list-style-type: none"> Bidder meets the 15% MWBE Goal List all MWBE firms to be utilized 	Due within 3 business days of notice of being apparent LRRB.
Affidavit D <i>Good Faith Efforts (GFE) & Statement of Compliance</i> <ul style="list-style-type: none"> Bidder does not meet the 15% MWBE Goal Documentation of GFE to be provided Minimum of 50 points 	Due within 3 business days of notice of being apparent LRRB.
REPORT FORMS	
DOCUMENT	SUBMISSION REQUIREMENTS
Contract Subcontractor Identification Form	Due within 30 days of contract award.
MWBE Good Faith Negotiation and Solicitation Forms (Optional)	Due upon request by the MWBE office.
Affidavit E <i>Subcontractor Payment Form</i>	Each invoice and final payment request.
Request to Change MWBE Subcontractor <ul style="list-style-type: none"> Firm may replace MWBE subcontractor For cause and with approval of the City Good Faith Efforts apply. 	Due throughout entire contract period. Anytime MWBE subcontractor change(s)

INFORMATION FOR BIDDERS REGARDING COMPLIANCE WITH THE CITY OF RALEIGH'S MINORITY AND WOMEN-OWNED BUSINESS ENTERPRISE (MWBE) PROGRAM

Policy

In accordance with North Carolina law, the City of Raleigh encourages and provides an equal opportunity for Certified Minority and Women-Owned Business Enterprises (MWBE) to participate in all aspects of the City's contracting and procurement programs.¹ The prime contractor or a first-tier subcontractor on a construction manager at risk (CMAR) project (collectively, "Bidder") shall be required to identify participation of MWBE businesses in its proposal, and document how that participation will be achieved. Bidders are subject to the City's MWBE subcontracting requirements (including good faith efforts as applicable), regardless if a Bidder is itself a Certified MWBE.²

The City has an aspirational goal of 15% of the total contract amount to be performed by MWBE businesses in contracts awarded by the City for: (i) construction and building projects of \$300,000 or more; and (ii) construction and building projects of \$100,000 or more that have any state funding.

Definitions

Certified Minority Business (MWBE)

A business which:

- a. At least fifty-one percent (51%) is owned by one or more Minority Persons or Socially and Economically Disadvantaged Individuals; or in the case of a corporation, in which at least fifty-one percent (51%) of the stock is owned by one or more Minority Persons or Socially and Economically Disadvantaged Individuals;
- b. The management and daily business operations are controlled by one or more Minority Persons or Socially and Economically Disadvantaged Individuals; and
- c. Is certified in one of the MWBE categories as defined by the NC Department of Administration/Historically Underutilized Business (HUB) and the NC Department of Transportation/Disadvantaged Business Enterprise (DBE).

Minority Person

A person who is a citizen or lawful permanent resident of the United States and who is:

- a. Black, that is, a person having origins in any of the black racial groups in Africa;
- b. Hispanic, that is, a person of Spanish or Portuguese culture with origins in Mexico, South or Central America, or the Caribbean Islands, regardless of race;
- c. Asian American, that is, a person having origins in any of the original peoples of the Far East, Southeast Asia, Asia, the Indian subcontinent, or the Pacific Islands;
- d. American Indian, that is, a person having origins in any of the original peoples of North America; or
- e. Non-minority Female.

Socially and Economically Disadvantaged Individual

Socially disadvantaged individuals are those who have been subjected to racial or ethnic prejudice or cultural bias because of their identity as a member of a group without regard to their individual qualities. Economically disadvantaged individuals are those socially disadvantaged individuals whose ability to compete in the free enterprise system has been impaired due to diminished capital and credit opportunities as compared to others in the same business area who are not socially disadvantaged.³

¹ See, N.C.G.S. §§ 143-128.2, 143-128.4, 143-129, and 143-131.

² See, City of Raleigh SOP 505-2.

³ See, 15 U.S.C. 637.

Bidder Responsibilities

Bidders agree to comply with all the terms and conditions of the City of Raleigh's Minority and Women-Owned Business Enterprise (MWBE) Program. Bidders must use good faith efforts (if applicable) to meet participation goals through the award of subcontracts to certified MWBE businesses consistent with City policy and North Carolina law.

Pre-Bid Opening

The City's Solicitation Documents include forms that: (a) capture information about MWBEs and any other subcontractors or suppliers that a Bidder intends to use on a contract ("Identification of MWBE Participation") and (b) affidavits to be completed by the Bidder.

Identification of MWBE Participation

The "Identification of MWBE Participation" must be completed by the Bidder on the City's form and submitted with its bid. If the project work is to be self-performed by the Bidder, the Bidder must so designate by checking the appropriate box on the form. For all Bidders which will not be self-performing the project work, the "Identification of MWBE Participation" form must be completed in its entirety. The Bidder must list on the City's form all MWBE businesses which will be construction subcontractors, vendors, or suppliers (collectively, "Subcontractors") on the project, and the total dollar value of its bid that will be performed by MWBEs. The failure to complete the "Identification of MWBE Participation" form in its entirety, or the failure to submit a completed "Identification of MWBE Participation" form with its bid, will render the bid non-responsive and the Bidder's bid will not be considered for award. The City will only credit MWBE participation for those Subcontractors listed on the "Identification of MWBE Participation" form.

Affidavit A: Listing of Good Faith Efforts

If the Bidder intends to subcontract any portion of the project work on a contract, an Affidavit A must be properly executed and submitted with its bid, listing the good faith efforts the Bidder made to achieve MWBE subcontracting goals for the contract prior to submitting its bid. The Affidavit A must be completed using the City's form. A minimum of fifty (50) good faith efforts points is required, the failure to achieve at least 50 points is grounds for rejection of a bid.

Affidavit B: Intent to Perform Contract with Own Workforce

In lieu of an Affidavit A, a Bidder that intends to perform 100% of the project work on a contract with its own current workforce may submit an Affidavit B with its bid. In submitting an Affidavit B, a Bidder certifies that the Bidder does not customarily subcontract elements of this type of project, and normally performs, has the capability to perform, and will perform all elements of the project work on the contract with its own current workforce. The Affidavit B must be completed using the City's form.

The failure to submit a properly executed Affidavit A or Affidavit B with a bid will render the bid non-responsive and the bid will not be considered for award.

Bid Opening

At the project bid opening, the total MWBE participation for each bid will be recorded. Upon being named the apparent low bidder, the Bidder must comply with the following:

- a. If the Bidder submitted an Affidavit B with its bid indicating its intent to perform 100% of the project work on the contract with its own current workforce, then the Bidder is not required to resubmit its Affidavit B or to submit any additional affidavits (i.e., Affidavit C or Affidavit D). The City, in its discretion, may request that the Bidder submit additional information or documentation, including, but not limited to, information relating to the Bidder's subcontracting history and its ability to perform all elements of the project work on the contract with its own current workforce.

- b. If the Bidder submitted an Affidavit A with its bid and the amount of MWBE participation as a percentage of the total contract price meets or exceeds the applicable goal, then the Bidder must submit to the City an Affidavit C within three (3) business days after being notified by City Staff that it is the apparent low bidder. The Bidder must complete the Affidavit C in its entirety using the City's form.
- c. If the Bidder submitted an Affidavit A with its bid and the amount of MWBE participation as a percentage of the total contract price does not meet the applicable goal, then the Bidder must submit an Affidavit D to the City within three (3) business days after being notified by City Staff that it is the apparent low bidder. The Bidder must complete Affidavit D in its entirety on the City's form. In conjunction with the Affidavit D, the Bidder must include supplemental documentation of the good faith efforts made to meet the applicable goal. The City, in its discretion, may request that the Bidder submit additional information or documentation, including, but not limited to, information or documentation relating to any good faith efforts claimed by the Bidder, and completion of the City's Good Faith Negotiation Form and Solicitation Form. Good faith efforts can be demonstrated using, among other factors, the following:
 - i. Attending pre-solicitation or pre-bid meetings that are scheduled by the City to inform MWBE firms of contracting, subcontracting, and supply opportunities.
 - ii. Advertising in general circulation, trade association, or minority-focus media concerning subcontracting opportunities.
 - iii. Providing written notice, to a reasonable number of specific MWBE firms that their interest in the contract is being solicited, at least 10 days before bids are due, to allow MWBE firms time to participate.
 - iv. Following up initial solicitation of interest by contacting MWBE firms to determine with certainty whether the MWBE firms are interested.
 - v. Identifying and selecting portions of the work to be performed by MWBE firms in order to increase the likelihood of MWBE participation (including where appropriate, breaking down contracts into economically feasible units to facilitate MWBE participation).
 - vi. Providing interested MWBE firms with equal access to plans, specifications, and requirements of the contract.
 - vii. Negotiating fairly with interested MWBE firms, not rejecting MWBE firms as unqualified without sound reasons based on a thorough investigation of their capabilities.
 - viii. Using the services of the City's MWBE office; available minority community organizations; minority contractors' groups; local, state, and federal minority business offices; and other organizations that provide assistance in the recruitment and placement of MWBE firms.
 - ix. Assisting interested MWBE firms in need of equipment, loan capital, lines of credit or joint pay agreements to secure loans, supplies or letters of credit, including waiving credit that is ordinarily required.
 - x. Assisting interested MWBE firms in obtaining bonding, insurance, or providing alternatives to bonding or insurance for Subcontractors.
 - xi. Negotiating joint venture and partnership arrangements with minority businesses to increase the opportunities for minority participation when possible.
 - xii. Provide for quick pay agreements and policies to enable minority contractors and suppliers to meet cash flow demands.

For each unmet MWBE participation goal, for which an Affidavit D is submitted, a Bidder must earn at least fifty (50) good faith efforts points. The failure to achieve at least fifty (50) points is grounds for rejection of a bid. All

actions necessary to earn good faith efforts points must occur prior to bid opening. In determining whether a Bidder has made good faith efforts, the City will evaluate the efforts made by the Bidder and will determine compliance with regard to quantity, intensity, and results of these efforts prior to recommendation of award.

Post-Award

Payment

For purposes of this section the word "Contractor" means both the prime contractor and the CMAR for CMAR projects. The Contractor must submit a completed **Payment Affidavit - Subcontractor / Supplier Utilization Form** with each payment application, including periodic payments and final payment. Payment applications will not be processed by the City until a completed Payment Affidavit – Subcontractor/ Supplier Utilization Form is submitted. Within seven (7) days of receipt by the Contractor of a periodic or final payment from the City, the Contractor must pay each first-tier Subcontractor based on work completed or services provided under each subcontract. If the Contractor has made a quick pay commitment with any MWBE Subcontractor, they must comply with the provisions of their quick pay commitment.

Changing a Certified MWBE Subcontractor

If the situation arises that it becomes necessary to terminate, replace, or reduce the work of a MWBE Subcontractor counted toward a committed MWBE subcontracting goal, the Contractor must submit a completed **Request to Change MWBE Subcontractor** form to the applicable department project manager and the City's MWBE Program Manager. Any change in the work of a MWBE Subcontractor, including its termination and/or replacement, must first be approved by the City based upon good cause shown. Any further explanation or detail to the City in addition to what is identified in the Request to Change MWBE Subcontractor form must be on company letterhead. Good faith efforts shall apply to the selection of any substitute Subcontractor.

ACKNOWLEDGMENT OF MWBE POLICY

The City's policy is to encourage bidders in the participation of MWBE businesses. A presentation of that policy has been made at the pre-bid or pre-proposal conference. By submission of a bid or proposal in response to this solicitation, the Bidder acknowledges consents to all the terms and conditions of the City of Raleigh Minority and Women-Owned Business Enterprise (MWBE) Policy. A copy of the policy may be provided upon request by the MWBE Program Office or online at www.raleighnc.gov.

Bidder recognizes that the City of Raleigh encourages and provides equal opportunity for MWBE businesses to participate in all aspects of the City's contracting and procurement. The City's MWBE participation aspirational goal is at least fifteen percent (15%) of the total contract amount to MWBEs on construction projects of \$300,000 or more and building related contracts of \$100,000 or more that include any State funding. The Bidder on the subject Contract/Proposal must document good faith efforts to provide meaningful participation by MWBEs in the performance of the Contract. Bidder agrees that the City may reject a bid for MWBE Policy violations, including but not limited to, providing inaccurate information or for failure to provide required MWBE documentation.

The Prime Contractor will be required to identify participation of MWBE businesses and how that participation will be achieved. Bidder must identify anticipated subcontractors, including any Minority & Women-Owned Businesses, intended to be used. Bidder further agrees, if awarded a Contract, it will, upon request, submit to the City, the proper affidavit identifying the workforce actually utilized on the Contract. All MWBE related bid documents have been provided to the Bidder. MWBE information provided by the Bidder is subject to the NC Public Records Act. Bidder acknowledges that the City must be notified of any change of subcontractors, suppliers, or subconsultants.

To the extent permitted by North Carolina law, the Bidder, their agents, officials, contractors, employees and servants agree not to discriminate in any manner on the basis of race, color, creed, national origin, sex, age, handicap, or sexual orientation with reference to the subject matter of this Contract/Proposal. The Bidder further agree, to the extent permitted by law, to conform with the provisions and intent of City of Raleigh Ordinance 1969-889, as amended. This provision is hereby incorporated herein for the benefit of the City of Raleigh and its residents, and may be enforced by action for specific performance, injunctive relief, or other remedy as provided by law. This provision shall be binding on the successors and assigns of the parties with reference to the subject matter of the Contract/Proposal.

I have read and understand the City of Raleigh's MWBE policy.

Signature

Printed Name and Title

Company

Date

IDENTIFICATION OF MWBE PARTICIPATION FOR INFORMAL PROJECT BIDS

Projects \$30,000 - \$299,999.99

This Identification of MWBE Participation Form is for the purpose of capturing information regarding the utilization of MWBEs and other subcontractors and suppliers on Informally Bid City Projects and Contracts. MWBE participation is encouraged for all City of Raleigh contracting opportunities. Please refer to the City's MWBE Policy for any contract specific requirements. *Copy this Form as needed.*

BIDDER NAME			
PROJECT NAME			
PROJECT NUMBER		CITY DEPARTMENT	
CONTRACT TYPE	<input type="checkbox"/> Construction <input type="checkbox"/> Services <input type="checkbox"/> Other _____*		
<input type="checkbox"/> PRIME IS MWBE	Classification: _____ <input type="checkbox"/> Certified with NCHUB <input type="checkbox"/> Certified with NCDOT-DBE	BID SUBMITTAL DATE	

MWBE Classifications: American Indian (AI), Asian American (AA), Black/African-American (B), Hispanic (H), Non-Minority Female (NMF), Socially/Economic Disadvantaged (D)
 *For Professional Services Contracts, please use the Identification of MWBE Participation for Professional Services Form

WORK TO BE SELF-PERFORMED

Check this box **only** if you intend to perform 100% of the work on this Project/Contract with your own current work forces, and you normally perform and have the capability to perform all elements of this work on this Project/Contract with your own current work forces.

MWBE SUBCONTRACTORS

Complete the chart below for all MWBE subcontractors that you intend to use on this Project/Contract regardless of dollar amount.

Company Name	MWBE Classification	Description of Services	Percentage of Total Contract*	Total Projected Utilization (\$)*

*MWBE Classifications: American Indian (AI), Asian American (AA), Black/African-American (B), Hispanic (H), Non-Minority Female (NMF), Socially/Economic Disadvantaged (D)
 *If the proposal is subject to an RFQ process, you may enter "N/A".

Total Estimated MWBE Utilization* \$ _____

Total Proposal Amount* \$ _____

Percent Estimated MWBE Utilization* _____ %

(Total Estimated MWBE Utilization divided by Total Bid Amount)

*If the proposal is subject to an RFQ process, you may enter "N/A".

NORTH CAROLINA
WAKE COUNTY

CONTRACT FOR CONSTRUCTION/REPAIR

THIS CONTRACT (the "Contract") is entered into by and between _____, hereinafter referred to as the "Contractor", and the City of Raleigh, a North Carolina municipal corporation, hereinafter referred to as the "City" for the project entitled: _____.

And for the not to exceed total Contract Amount of: _____ (in written word and numerals), unless changed by a duly authorized amendment or change order.

WITNESSETH:

WHEREAS, the City desires to procure a contractor to perform services; and

WHEREAS, the City has completed necessary steps for retention of construction/repair services under State law and applicable City policies; and

WHEREAS, the City has agreed to engage the Contractor, and the Contractor has agreed to contract with the City, for performance of services as described, and according to the further terms and conditions, set forth herein.

NOW THEREFORE, in consideration of sums to be paid to the Contractor, and other good and valuable consideration, the Contractor and City do contract and agree as follows:

1. Description of Work

The Contractor, at its own proper cost and expense and with skill and diligence, shall furnish all labor, tools, materials and equipment and do all things necessary for the proper construction and completion ready for use of the following improvements:

-

In strict accordance with and as shown in the specifications, schedules, drawings and other documents set forth herein or incorporated by reference as follows:

-

The Contractor shall further perform in accordance with the directions (not inconsistent therewith) given from time to time during the construction by the project engineer or of such other official, employee, or other agent of the City as the City may designate.

2. General Obligations of the Contractor

The Contractor will accept the prices specified in this Contract in full compensation and satisfaction for the performance of this Contract and as consideration of this Contract. The Contractor shall be responsible for all loss and damages of every kind and nature which may arise out of or an account of the performance of the work required by this Contractor, and for all risks of every description connected with the said work; and the Contractor shall be responsible for well and faithfully completing the whole work according to all applicable plans and specifications and the terms and conditions of this Contract.

3. Time of Commencement and Completion

The entire work required by this Contract shall be completed by the Contractor not later than _____ days after the date of Notice-to-Proceed.

4. Workmanship and Quality of Services/Warranties

All work under this Contract shall be done and performed to the satisfaction of the project engineer of the City of Raleigh, or of such other official, employee, or agent of the City as may be designated by the City, and such official, employee or agent designated by the City shall in all cases of dispute determine the quantity, quality, acceptability and fitness of the work and materials and of several portions thereof which are to be paid for under this Contract and shall decide and determine all questions which may arise as to the measurements, lines, levels and dimensions of the work and all questions respecting the true construction, interpretation or meaning of the plans and specifications. In case of dispute between the Contractor and the said official, employee, or agent of the City, the decision and determination of the latter shall be taken and shall be final and conclusive.

- 4.1. The Contractor, in executing this Contract, warrants that it will be responsible for the maintenance or correction of any work completed under this Contract that may become defective due to faulty workmanship or materials for a period of one (1) year after final acceptance of the work performed.
- 4.2. It is understood and agreed by the parties hereto that work done under this Contract shall be subject to all ordinances of the City of Raleigh relating to work done in the public streets or other public property of the City. Particularly reference is made to the provisions of Part 11, Chapter 6 of the Raleigh City Code.

5. Compensation

In consideration of the performance of this Contract and the full completion of the work required of the Contractor by the terms and conditions of this Contract, the City agrees to pay to the Contractor the contract amount based on the following:

- 5.1. Partial payments will be made to the Contractor by the City NET thirty (30) days after presentation of a true and accurate payment application to the City as certified by the Project Engineer or agent of the City.
- 5.2. All invoices must include the following Purchase Order Number _____.
- 5.3. Final estimate of the amount due to the Contractor will be made within thirty (30) days after the certified completion and final acceptance of all the work required by the Contract less retainage per Section 6. Payment to the Contractor by the City of the amounts so determined to be due, in accordance with this Contract, shall relieve the City from all claims for work done and materials and equipment furnished under this Contract.
- 5.4. It is further mutually agreed between the parties that no estimate or partial payment made under this Contract shall be conclusive evidence of the performance of this Contract, either wholly or in part, and that no such payment shall be construed to be an acceptance of defective work or improper materials.

6. Retainage

This section will only apply if this public construction contract pertains to a project in which the total project costs are equal to or greater than one hundred thousand dollars (\$100,000.00).

To ensure proper performance of the Contract, the City may retain five percent (5%) of the amount of each approved partial or periodic payment application until the project work is fifty percent (50%) complete, provided that the Contractor continues to perform satisfactorily and any non-conforming work identified in writing prior to that date has been corrected by the Contractor and accepted by the construction manager.

If the City determines the Contractor's performance is unsatisfactory, the City may reinstate retainage in the amount of five percent (5%) for each subsequent partial or periodic payment application until the Contractor's performance becomes satisfactory. The project shall be deemed fifty percent (50%) complete when the contractor's gross project invoices, excluding the value of materials stored off-site, equal or exceed fifty percent (50%) of the value of the contract, except the value of materials stored on-site shall not exceed twenty percent (20%) of the contractor's gross project invoices for the purpose of determining whether the project is fifty percent (50%) complete. Following fifty percent (50%) completion of the project, the City may also withhold additional retainage from any subsequent periodic payment, not to exceed five percent (5%), in order to allow the City to retain two and one-half percent (2 ½%) total retainage through the completion of the project.

Within sixty (60) days after the submission of a pay request, the City with written consent of the surety shall release to the Contractor all retainage on payments held by the City if (1) the City receives a certificate of substantial completion from the architect, engineer, or designer in charge of the project; or (2) the City receives beneficial occupancy or use of the project. However, the City may retain sufficient funds to secure completion of the project or corrections on any work. If the City retains funds, the amount retained shall not exceed two and one-half (2 ½) times the estimated value of the work to be completed or corrected. Any reduction in the amount of the retainage on payments shall be with the consent of the contractor's surety.

Retainer provisions contained in Contractor's subcontracts may not exceed the terms and conditions for retainage provided herein. Contractors are further required to satisfy the retainage provisions of N.C.G.S. 143-134.1(b2) with regard to subcontracts for early finishing trades (structural steel, piling, caisson, and demolition) and to coordinate the release of retainage for such trades from the retainage held by the City from the Contractor pursuant to statute. Nothing shall prevent the City from withholding payment to the Contractor in addition to the amounts identified herein for unsatisfactory job progress, defective construction not remedied, disputed work, or third-party claims filed against the City or reasonable evidence that a third-party claim will be filed.

7. Notices

Except as otherwise expressly provided in this Contract, all notices, requests for payment, or other communications arising hereunder shall be sent to the following:

City of Raleigh

Attn:
Title:
Address 1: P.O. Box 590
Address 2: Raleigh, NC 27602
Telephone:
E-mail:

Contractor

Attn:
Title:
Address 1:
Address 2:
Telephone:
E-mail:

8. Non-Discrimination

- 8.1. To the extent permitted by North Carolina law, the Parties for themselves, their agents, officials, directors, officers, members, representatives, employees, and contractors agree not to discriminate in any manner or in any form based on actual or perceived age, mental or physical disability, sex, religion, creed, race, color, sexual orientation, gender identity or expression, familial or marital status, economic status, veteran status or national origin in connection with this Contract or its performance.
- 8.2. The Parties agree to conform with the provisions and intent of Raleigh City Code §4-1004 in all matters related to this Contract. This provision is incorporated into the Contract for the benefit of the City of Raleigh and its residents and may be enforced by an action for specific performance, injunctive relief, or any other remedy available at law or equity. This section shall be binding on the successors and assigns of all parties with reference to the subject matter of the Contract.

9. Minority and Women Owned Business Enterprise

The City of Raleigh prohibits discrimination in any manner against any person based on actual or perceived age, race, color, creed, national origin, sex, mental or physical disability, sexual orientation, gender identity or expression, familial or marital status, religion, economic status, or veteran status. The City maintains an affirmative policy of fostering, promoting, and conducting business with women and minority owned business enterprises.

To further this policy, the City has an aspirational goal of 15% participation by certified minority and women-owned businesses in City construction and repair contracts for building projects with a cost of \$300,000 or more or building projects with a cost of \$100,000 or more with state funding.

10. Assignment

This Contract may not be assigned without the express written consent of the City.

11. Applicable Law

All matters relating to this Contract shall be governed by the laws of the State of North Carolina, without regard to its choice of law provisions, and venue for any action relating to this Contract shall be Wake County Civil Superior Court or the United States District Court for the Eastern District of North Carolina, Western Division.

12. Insurance

Contractor agrees to purchase at its own expense insurance coverages to satisfy the following minimum requirements. A certificate reflecting the following minimum coverages shall accompany this Contract:

12.1. Workers' Compensation Insurance:

Limits:

Workers Compensation:	Statutory for the State of North Carolina
Employers Liability:	Bodily Injury by Accident \$1,000,000 each accident
Bodily Injury by Disease	\$1,000,000 policy limit
Bodily Injury by Disease	\$1,000,000 each employee

12.2. Commercial General Liability:

Limits:

Each Occurrence:	\$1,000,000
Personal and Advertising Injury	\$1,000,000
General Aggregate Limit	\$2,000,000
Products and Completed Operations Aggregate	\$2,000,000

The aggregate limit must apply per project. The form of coverage must be the ISO CG 00 01 policy as approved by the State of North Carolina Department of Insurance. If a form of coverage other than the CG 00 01 is used it must be approved by the City's risk manager. Any endorsed exclusions or limitations from the standard policy must be clearly stated in writing and attached to the Certificate of Insurance. Completed Operations coverage must be maintained for the period of the applicable statute of limitations.

12.3. Commercial Automobile Liability:

Limits:

\$1,000,000 combined single limit.

12.4. Additional Insured:

Contractor agrees to endorse the City as an Additional insured on the Commercial General Liability, Auto Liability and Umbrella Liability if being used to meet the minimum liability limits for General Liability and Automobile Liability.

The Additional Insured shall read 'City of Raleigh is named additional insured as their interest may appear'.

The Certificate Holder address should read:

City of Raleigh
Post Office Box 590
Raleigh, NC 27602-0590

12.5. Builders Risk Coverage:

Limits:

Minimum limit in the amount of total bid price. The Builder Risk policy must be endorsed to increase the limit of insurance for all change orders.

12.6. Policy Form:

Builder Risk coverage must be on a direct physical loss basis and contain no exclusion for theft, collapse or damage to foundations or underground structures, pipes or conduits.

12.7. Named Insured:

The Named Insured shall be The City of Raleigh, the Contractor, and all sub-contractors with a contractual assumption of responsibility for damage to the project.

All insurance companies must be admitted to do business in North Carolina and be acceptable to the City's risk manager. If the insurance company(s) is a permitted surplus lines insurer, the insurance company name, and NAIC number must be submitted to the City's risk manager for approval before

commencing work. Contractor shall be required to provide the City no less than thirty (30) days' notice of cancellation, or any material change, to any insurance coverage required by this Contract.

A Certificate of Insurance (COI) must be issued by an authorized representative of the insurance carrier(s). Certificates of Insurance must have the insurance company name and NAIC number clearly identified. The acceptance of or the review of Certificates of Insurance by the City does not relieve Contractor of any requirements in the Contract to provide specific insurance coverage required by the Contract, nor does the acceptance of or review of Certificates of Insurance covenant all insurance requirements have been met.

13. Surety Bonds

If Surety Bonds are required by the City for this project, the Contractor shall have furnished and attached hereto a performance bond and a payment bond each in the penal sum of the full Contract amount covering the faithful performance of the Contract and the payment of all obligations arising hereunder, in such form and content as the City may prescribe and with surety approved by the City. Should any surety upon the bond for the performance of this Contract become unacceptable to the City, the Contractor must promptly furnish additional security as may be required from time to time by the City to protect the interests of the City and of persons, firms and corporations supplying labor or materials in the performance of the work contemplated by the Contract.

14. Indemnity

- 14.1. To the fullest extent allowed by law, Contractor shall indemnify, defend, and hold harmless the City, its officers, officials, employees, agents, or indemnities (collectively called "Indemnified Parties") from and against those Losses, liabilities, damages, and costs proximately caused by, arising out of, or resulting from the sole negligence of the Contractor, the Contractor's agents, or the Contractor's employees.
- 14.2. In matters other than those covered by subsection 14.1. above, and to the fullest extent allowed by law, Contractor shall indemnify, defend, and hold harmless the Indemnified Parties from and against those Losses, liabilities, damages, and costs caused by, arising out of, resulting from, or in connection with the execution of the work provided for in this Agreement when the Fault of the Contractor or its Derivative Parties is a proximate cause of the Loss, liability, damage, or expense indemnified.
- 14.3. Costs and expenses shall include attorneys' fees, litigation or arbitration expenses, or court costs actually incurred by the Indemnified Parties to defend against third-party claims alleged in any court, tribunal, or alternative dispute resolution procedure required of any of the Indemnified Parties by law or by contract, only if the Fault of the Contractor or its Derivative Parties is a proximate cause of the attorney's fees, litigation or arbitration expenses, or court costs to be indemnified.
- 14.4. The Contractor's duty to indemnify, defend, and hold harmless described hereinabove shall survive the termination or expiration of this Contract.
- 14.5. Definitions:
 - 14.5.1. For the purposes of this Section 14, the term "Fault" shall mean any breach of contract; negligent, reckless, or intentional act or omission constituting a tort under

applicable statutes or common law; or violation of applicable statutes or regulations.

14.5.2. For the purposes of this Section 14, the term “Loss” or “Losses” shall include, but not be limited to, fines, penalties, and/or judgments issued or levied by any local, state, or federal governmental entity.

14.5.3. For the purposes of this Section 14, the term “Derivative Parties” shall mean any of the Contractor’s subcontractors, agents, employees, or other persons or entities for which the Contractor may be liable or responsible as a result of any statutory, tort, or contractual duty.

15. Communications

If communications to the public and/or City employees are required as part of the Contractor’s scope of work under this Contract, then the Contractor shall work with the City in the development of a communications plan (“Communications Plan”) that must first be approved by the City in writing before any such communications are delivered to the public and/or City employees.

For purposes of this Section 15, such written approval by the City shall be provided by electronic mail by the applicable City Communications Department employee who is responsible for reviewing and approving the Communications Plan, such electronic mail to be sent to the electronic mail address listed in Section 7, above, as part of the contact information for the Contractor representative identified in Section 7, above.

Among other things, the Communications Plan must establish whether the City or the Contractor will be responsible for sending any such communications to the public and/or City employees as required either by this Contract or the Communications Plan. The Communications Plan also shall include, but not be limited to, communications objectives, target audience, and deliverables (print, video, website, social, direct, or digital). The Contractor shall comply with the Communications Plan when communicating to the public and/or City employees pursuant to this Contract and the Communications Plan. All such communications shall comply with the City’s brand and communications guidelines, as the same may be amended or modified from time to time.

The City’s current brand and communications guidelines are incorporated into this Contract by reference and can be found on the City’s website here: <https://raleighnc.gov/doing-business/city-brand-guidance-vendors>.

For purposes of this Section 15, “Communications” is defined as any public or City employee facing information presented in channels such as, but not limited to, a website, mobile applications, social media, printed materials, vehicles, billboards, and videos.

15.1. Communications Plan Approval:

Any materials, messaging or outreach from the Contractor related to marketing and communications of any service or effort under this Contract must first be reviewed and approved by the City’s Communications Department. This is to ensure that the Communications Plan: (i) complies with the City’s brand and communication guidelines; (ii) integrates with the City’s other communications channels and digital strategy; (iii) meets

accessibility guidelines; and (iv) conforms to communications best practices with respect to general user experience.

15.2. Accessibility Requirements:

For web content that the Contractor is to make accessible to the public and/or City employees as part of an approved Communications Plan that is included in the Contractor's scope of work under this Contract, all web materials including, but not limited to, tools, mobile applications, and websites, generated by, or on behalf of, the Contractor must meet at least the mid-range conformance level, AA compliance of the current Web Content Accessibility Guidelines, as the same may be amended from time to time.

Any such web content generated by, or on behalf of the Contractor, as part of a Communications Plan associated with this Contract shall meet all standards of good cognitive web accessibility, which include the following:

15.2.1. Using proper headings and lists

15.2.2. Using unique links

15.2.3. Using alternative text and captions

15.2.4. Using more white space

15.2.5. Dividing content into more manageable pieces

15.2.6. Making forms manageable by breaking them into multiple, sequential steps

15.2.7. Providing a logical reading order

15.2.8. Being consistent with fonts, colors and locations of page elements

15.2.9. Offering keyboard access

15.2.10. Offering content in multiple formats

15.2.11. Understanding minimum contrast

15.3. Languages:

Digital sites/ tools that are for public use/consumption, including for use by City employees, under a Communications Plan associated with this Contract must have translation module (e.g., G-translate, Weglot) so that the service is available in all languages. At minimum, Spanish translation is required on all such digital sites/tools based on low English proficiency requirements:

15.3.1. In most cases, entities that are recipients of federal financial assistance through U.S. Department of Health and Human Services (HHS) must provide language assistance services in order to comply with their legal obligation to take reasonable steps to ensure meaningful access to their programs by persons with Limited English Proficiency (LEP).

15.4. Content:

For any communications content that the Contractor is required to generate, or have generated, as part of its scope of work under this Contract, the Contractor shall send such content to City Communications Department staff in raw, high-resolution format for inclusion in communications materials to be made accessible to the public and/or City employees as set forth in the Communications Plan that arises from this Contract (i.e., websites, mobile applications, printed materials collateral, and social media). PDF attachments shall be used only as a last resort and only after written approval by the City, with such written approval to be provided by the City in electronic mail format as described elsewhere in this Section 15.

15.4.1. Contractor shall only provide to the City communications materials for which the City has rights to use, with written documentation of such use rights being provided to the City as requested from time to time by the City in its sole discretion.

15.4.2. All working files agreed upon for the specific Communications Plan shall be provided to the City Communications Department, i.e., text, graphics, charts and data, infographics, and original native files such as Illustrator, Excel, ArcGIS, etc. Following are the file format specifications:

15.4.2.1. Images: At least 300dpi for printing at actual size; 96dpi and at least 1920x1080px for digital/Web.

15.4.2.2. Video: Any video should be no less than Standard HD (1920x1080) but preferable 4k.

15.4.2.3. Text: Word document using accessibility best practices (heading structure, table of contents, and tables).

16. Advertising

The Contractor shall not use the existence of this Contract, or the name of the City, as part of any advertising without prior written approval of the City.

17. Acknowledgement of City Brand and Tree Logo Ownership and Restrictions

The City of Raleigh has developed proprietary branding (the “City Brand”) centered around the Raleigh tree mark logo (the “Tree Logo”). The City’s exclusive rights and ownership in and to the Tree Logo are protected under trademark and copyright, including U.S. Copyright Reg. No. VAu1-322-896, N.C. State Trademark Registration Reg. No. T-23070 and Federal Trademark Registration Reg. No. 5,629,347, as well as under other federal and state laws.

Contractor acknowledges and understands that the City is not conferring any license to Contractor under this Agreement to use or depict the Tree Logo or other aspects of the City Brand. Contractor shall not make any use or depiction of the Tree Logo or other aspects of the City Brand without the prior express written approval of the City. In this regard, should any materials being produced by Contractor for the City under this Agreement contemplate use or depiction of the Tree Logo, including, but not limited to, printed materials, digital media, signage and/or display materials, Contractor shall proceed under the auspices and direction of the City’s Communications Department and shall comply with all guidelines and restrictions governing use or depiction of the Tree Logo.

18. Force Majeure

Except as otherwise provided in any environmental laws, rules, regulations or ordinances applicable to the parties and the services performed under this Contract, neither party shall be deemed to be in default of its obligations hereunder if and so long as it is prevented from performing such obligations by an act of war, hostile foreign actions, nuclear explosion, earthquake, hurricane, tornado, or other catastrophic natural event or act of God. Either party to the Contract must take reasonable measures and implement reasonable protections when a weather event otherwise defined as a force majeure event is forecast to be eligible to be excused from the performance otherwise required under this Contract by this provision.

19. Termination

If the Contractor fails to perform the work described herein by the time allowances provided in Section 3 or fails to provide adequate staff and resources required to properly execute said work in a workmanlike and safe manner, the City can declare the Contractor in Default. If the Contractor fails to complete the work in the provided project duration as stated in Section 3 of this Contract, or fails to meet periodic schedules describing work sequence, or fails to comply with all appropriate local, federal, or state laws, rules and regulations, then the City may, without prejudice to any other right or remedy and after giving the Contractor and its surety a maximum of seven (7) days from delivery of a written notice, declare the Contract in default, take possession of the project and of all equipment, tools, materials thereon owned by the Contractor and call upon the surety or appropriate legal recourse to finish the work by whatever method deemed expedient.

20. Laws/Safety Standards

- 20.1. The Contractor shall comply with all laws, ordinances, codes, rules, regulations, safety standards and licensing requirements that are applicable to the conduct of its business, including those of federal, state, and local agencies having jurisdiction and/or authority.
- 20.2. All manufactured items and/or fabricated assemblies subject to operation under pressure, operation by connection to an electric source, or operation involving a connection to a manufactured, natural, or LP gas source shall be constructed and approved in a manner acceptable to the appropriate state inspector which customarily requires the label or re-examination listing or identification marking of the appropriate safety standard organization, such as the American Society of Mechanical Electrical Engineers for pressure vessels; the Underwriters' Laboratories and/or National Electrical Manufacturers' Association for electrically operated assemblies; or the American Gas Association for gas operated assemblies, where such approvals of listings have been established for the type(s) of devices offered and furnished. Further, all items furnished by the Contractor shall meet all requirements of the Occupational Safety and Health Act (OSHA), and state and federal requirements relating to clean air and water pollution.
- 20.3. Contractor must comply with *North Carolina Occupational Safety and Health Standards for General Industry 13 NCAC 07F (29CFR 1910)*. In addition, Contractor shall comply with all applicable occupational health and safety and environmental rules and regulations.
- 20.4. Contractor shall effectively manage its safety and health responsibilities including:
 - 20.4.1. Accident Prevention:

Prevent injuries and illnesses to its employees and others on or near the job site. Contractor managers and supervisors shall ensure personnel safety by strict adherence to established safety rules and procedures.

20.4.2. Environmental Protection:

Protect the environment on, near, and around the work site by compliance with all applicable environmental regulations.

20.4.3. Employee Education and Training:

Provide education and training to all contractors employees before they are exposed to potential workplace or other hazards as required by specific OSHA Standards.

21. Applicability of North Carolina Public Records Law

Notwithstanding any other provisions of this Contract, this Contract and all materials submitted to the City by the Contractor are subject to the public records laws of the State of North Carolina and it is the responsibility of the Contractor to properly designate materials that may be protected from disclosure as trade secrets under North Carolina law as such and in the form required by law prior to the submission of such materials to the City. Contractor understands and agrees that the City may take any and all actions necessary to comply with federal, state, and local laws and/or judicial orders and such actions will not constitute a breach of the terms of this Contract. To the extent that any other provisions of this Contract conflict with this section, the provisions of this section shall control.

22. Miscellaneous

- 22.1. The Contractor shall be responsible for the proper custody and care of any property furnished or purchased by the City for use in connection with the performance of this Contract and will reimburse the City for the replacement value of its loss or damage. The Contractor shall keep the job sites and surrounding area reasonably free from rubbish at all times and shall remove debris from the site from time to time or when directed to do so by the City. Before final inspection and acceptance of the project, the Contractor shall thoroughly clean the job sites, and completely prepare the project and site for use by the City.
- 22.2. The Contractor shall be considered to be an independent contractor and as such shall be wholly responsible for the work to be performed and for the supervision of its employees. Nothing herein is intended or will be construed to establish any agency, partnership, or joint venture. Contractor represents that it has, or will secure at its own expense, all personnel required in performing the services under this Contract. Such employees shall not be employees of or have any individual contractual relationship with the City.
- 22.3. This Contract may be amended only by written agreement of the parties executed by their authorized representatives.

23. Right of Audit and Examination of Records

- 23.1. The City may conduct an audit of any services performed and fees paid subject to this Contract. The City, or its designee, may perform such an audit throughout the contract period and for three (3) years after termination thereof or longer if otherwise required by law.

- 23.2. The Contractor and its agents shall maintain all books, documents, papers, accounting records, contract records and such other evidence as may be appropriate to substantiate costs incurred under this Contract. The City, or its designee, shall have the right to, including but not limited to: review and copy records; interview current and former employees; conduct such other investigation to verify compliance with Contract terms; and conduct such other investigation to substantiate costs incurred by this Contract.
- 23.3. "Records" shall be defined as data of every kind and character, including but not limited to books, documents, papers, accounting records, contract documents, information, and materials that, in the City's sole discretion, relate to matters, rights, duties or obligations of this Contract.
- 23.4. Records and employees shall be available during normal business hours upon advanced written notice. Electronic mail shall constitute written notice for purposes of this section.
- 23.5. Contractor shall provide the City or its designee reasonable access to facilities and adequate and appropriate workspace for the conduct of audits.
- 23.6. The rights established under this section shall survive the termination of the Contract, and shall not be deleted, circumvented, limited, confined, or restricted by contract or any other section, clause, addendum, attachment, or the subsequent amendment of this Contract.
- 23.7. The Contractor shall reimburse the City for any overcharges identified by the audit within ninety (90) days of written notice of the City's findings.
- 23.8. If an audit discloses overpricing or overcharges by the Contractor or Subcontractor in excess of one percent (1%) of the total contract billings, the Contractor shall reimburse the City for the cost of the audit.
- 23.9. Contractor shall ensure that all contracts with any subcontractors provide the City with an equivalent right to audit as contained herein.
- 23.10. Contractor shall, upon request, provide any records associated with this engagement to the North Carolina State Auditor that are necessary to comply with the provisions of G.S. § 147-64.7.

24. Incorporation of Documents/Complete Agreement

This Contract, and any documents incorporated below, represent the entire Contract between the parties and suspend all prior oral or written statements, agreements or Contracts.

Specifically incorporated into this Contract are the following attachments, or if not physically attached, are incorporated fully herein by reference:

- Bid Advertisement/City-issued bid document
- Contractor's Bid-response document
- Procedure for N.C. Sales Tax Reporting
- Performance Bond (w/Power-of-Attorney)
- Payment Bond (w/Power-of-Attorney)
- Certificate of Insurance

- General Conditions
- Special or Supplemental Conditions
- Job Specifications
- SDMWOB Affidavits/documentation
- Other (Describe) _____

In case of conflict between this Contract and any of the incorporated attachments or references listed above, the terms of this Contract shall prevail.

25. E – Verify

Contractor shall comply with *E-Verify*, the federal E-Verify program operated by the United States Department of Homeland Security and other federal agencies, or any successor or equivalent program used to verify the work authorization of newly hired employees pursuant to federal law and as in accordance with N.C.G.S. §64-25 *et seq.* In addition, to the best of Contractor’s knowledge, any subcontractor employed by Contractor as a part of this contract shall be in compliance with the requirements of E-Verify and N.C.G.S. §64-25 *et seq.* In cases of conflict between this Contract and any of the above incorporated attachments or references, the terms of this Contract shall prevail.

26. Iran Divestment Act Certification

Contractor certifies that, as of the date listed below, it is not on the final divestment list as created by the State Treasurer pursuant to N.C.G.S. § 147-86.55, et seq. In compliance with the requirements of the Iran Divestment Act and N.C.G.S. § 147-86.59, Contractor shall not utilize in the performance of the Contract any subcontractor that is identified on the final divestment list.

27. Companies Boycotting Israel Divestment Act Certification

Contractor certifies that it has not been designated by the North Carolina State Treasurer as a company engaged in the boycott of Israel pursuant to N.C.G.S. 147-86.81.

The remainder of this page is left blank intentionally.

IN WITNESS WHEREOF, the parties hereto have executed this Contract by digital signature, under seal, on the respective dates below, and this Contract shall be effective upon the date of the City's signature.

CONTRACTOR:

CITY:

CITY OF RALEIGH
a North Carolina municipal corporation

By:

By:

_____(SEAL)
Signature

Signature

Name

Name

Title

Choose an item.

Title

Choose an item.

Department

Date of Signature

Date of Signature

ATTEST:

ATTEST:

Signature

_____(SEAL)
City Clerk (or designee)

Name

Title

This instrument has been pre-audited in the manner required by the Local Government Budget and Fiscal Control Act.

Chief Financial Officer (or designee)

City of Raleigh Contract ID Number xxxxxxxxxxxx

Scope of Work

2026-Walnut Creek Athletic Complex-Batting Cage Installation

Walnut Creek Athletic Complex

1201 Sunnybrook Road

Raleigh, NC 27610



Project Description

Walnut Creek Athletic Complex fields play a major role in our effort to make athletic fields available to Raleigh's citizens and visitors. These fields serve as baseball/softball fields for City of Raleigh programming and supports various other user groups for a wide variety of play. The primary purpose of this project is to install a dual lane batting cage package, per manufacturer's specifications package.

Scope of Work (Base Bid)

- Installation of Jaypro Outdoor Batting Cage Tunnel, per attached specifications
- Installation of concrete pad, per attached specifications.

Scope of Work (Alternate # 1 – Installation of Synthetic Turf Surface on Concrete Pad

- Install Turf Distributors Eco 85 Silver Putt, or equivalent material

Scope of Work (Alternate # 2) - Installation of ADA sidewalk connector

- Provide costs per square feet to install concrete sidewalk connector, per specifications

General Guidelines:

- Site cleanup - During construction and upon completion, project site to remain free of loose materials. Coordinate with COR staff for proper staging of materials and equipment. Contractor to address any damage to field with COR staff.
- Field corrections/deviations from specifications – Address any concerns with COR staff prior to execution of any non-specified work.



-- MPCTF-55S --

-- MPCTF-70S --

**55ft and 70ft MEGA POST & CABLE
OUTDOOR BATTING TUNNEL FRAME
CAGE**







Installation Instructions



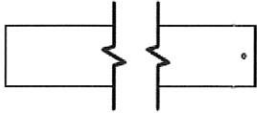

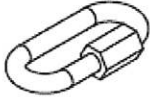

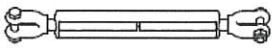

Call Jaypro Sports Equipment at 1-800-243-0533
during regular business hours for technical support.

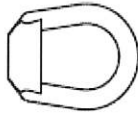
www.jaypro.com

MEGA POST & CABLE OUTDOOR BATTING TUNNEL FRAME CAGE PARTS LIST (QTY: SINGLE UNIT)

ITEM	IMAGE	DESCRIPTION	QTY
1		17'-0" UPRIGHT POST <i>P/N: MBT-8U</i>	4
2		1/4" CABLE THIMBLE <i>P/N: HM6079</i>	10
3		3/8" QUICK-LINK <i>P/N: HM6052</i>	6
4		1/4" CABLE CLAMP <i>P/N: HM6078</i>	24
5		1/2" GALV. TURNBUCKLE <i>P/N: HM6273</i>	4
6		1/4" GALV. AIRCRAFT CABLE x 16 FT <i>P/N: RC5014</i>	2
7		1/4" GALV. AIRCRAFT CABLE x 61 FT 70 FT cage uses 76 FT long aircraft cable. <i>P/N: RC5014</i>	3
ITEM	IMAGE	DESCRIPTION	QTY

ITEM	IMAGE	DESCRIPTION	QTY
9		1/2"-13 EYE NUT <i>P/N: HN5078</i>	8
11		1/2"-13 x 9" LONG HEX BOLT <i>P/N: HS5385</i>	8
13		1/2" STD FLAT WASHER <i>P/N: HW2044</i>	16
14		1/2" SPLIT WASHER <i>P/N: HW2124</i>	8
16		SNAP HOOK (1/4" x 2 3/8") <i>P/N: HM5013</i> <i>70 FT cage uses 73 snap hooks.</i>	58 73
17		ALL-STAR SERIES TUNNEL NYLON NET <i>P/N: BBC36-5514 / BBC36-7014</i>	1
ITEM	IMAGE	DESCRIPTION	QTY

IMPORTANT NOTICE:

1. BEFORE EACH USE CHECK EQUIPMENT FOR PROPER CONNECTING HARDWARE AND STRUCTURAL INTEGRITY. REPLACE DAMAGED OR MISSING HARDWARE IMMEDIATELY.
2. NEVER ALLOW ANYONE TO CLIMB OR HANG ON THE NET OR UPRIGHT POLE. AS SERIOUS INJURY OR DAMAGE TO THE EQUIPMENT MAY OCCUR.
3. USE OF THIS EQUIPMENT OTHER THAN INTENDED, MAY BE HAZARDOUS.
4. ALTERATION OR MODIFICATION OF THIS EQUIPMENT MAY BE HAZARDOUS AND RESULT IN INJURY. FOR REPAIR OR REPLACEMENT, CONTACT YOUR DEALER OR JAYPRO SPORTS.
5. NETS SHOULD BE REMOVED AND STORED AFTER THE SEASON IS OVER.
6. NETS SHOULD BE REMOVED PRIOR TO A MAJOR STORM OR HIGH WINDS.
7. THE RISK OF INJURIES CAN BE GREATLY REDUCED BY FOLLOWING PROPER SAFETY GUIDELINES, PROVIDING PROPER MAINTENANCE PERFORMING ROUTINE SAFETY INSPECTIONS ON THE NET, POLE AND HARDWARE.
8. SAFETY PRECAUTIONS AND ADULT SUPERVISION MUST BE OBSERVED AT ALL TIMES TO MINIMIZE THE POSSIBILITY OF ACCIDENTAL INJURES.
9. SPECTATORS MUST BE INSTRUCTED TO STAND A SAFE DISTANCE FROM THE NETTING WHEN THE BATTING CAGE IS IN USE, TO AVOID THE POSSIBILITY OF BODILY CONTACT WITH BALLS, BATS OR OTHER EQUIPMENT.
10. MAKE SURE NETTING DOESN'T CONTACT ANYTHING SOLID, SUCH AS A WALL OR CHAIN LINK FENCE.
11. TUNNEL NETS SHOULD BE REMOVED AND STORED PRIOR TO AN IMPENDING STORM WITH HIGH WINDS.
12. CONTACT JAYPRO SPORTS FOR REPLACEMENTS NETS AND HARDWARE

GENERAL MAINTENANCE:

- Batting tunnels nets should be removed and stored during the offseason or when not in use. Exposure to harsh winter weather will greatly reduce the life of a net.
- The tension cable and hardware should be closely inspected periodically, at the beginning and end of each season, or no less than twice a year.
- Any hardware that is corroded should be replaced immediately.
- Inspect each pole for rust and corrosion. If needed, brush area with a wire brush and repaint with an exterior grade rust-resistant enamel. If severe rust is noticed, particularly at the base, immediately stop using the cage. Loosen the cable tension and notify facility personnel.
- The cables may require periodic adjusting of the cable tension.
- The net should be closely inspected for wear and tears. Worn and weathered net, although still intact, lose their strength and ability to stop the ball. Replace any net that shows signs of wear or has tears or openings.

Tools Require:

- 1 3/4" and 3/8" Socket Wrench and Box Wrench
- 1 3/8" Nut Driver

- Unpack all parts and check against parts list to ensure that all have been included.
- Inspect all parts for damage. Report any damages to the trucking company.

I. Install Footing:

Note: See plan view for upright post layout, Figure 1.

- 1) Select a site for the tunnel frame that is flat and clear of obstructions. The ground should be level and free of debris. The minimum area required for a MPCTF-55S is 64 ft x 21 ft. - that required for MPCTF-70S is 79 ft x 21 ft.
- 2) Layout the foundations as shown in Figure 1. (Note: the MPCTF-55S layout is designed for a 55 ft long net, and the MPCTF-70S layout is designed for a 70 ft long net. Layout dimensions should be adjusted if using a different length net - the overall length of the frame should be 5 ft longer than the net.)
- 3) Dig footings as shown in Figure 2. A six-piece rebar basket is recommended. Pour a 6" concrete pad at the bottom of the footing, allow to cure for 24 hours.
- 4) Insert the pole, centered in the footings and support it in both directions.

Important: Verify the orientation of the holes in the top of the posts before proceeding. The upper holes should be in-line with the length of the net and the lower holes should line up with the ends of the net – see Figure 3.

- 5) Pour the concrete and allow it to cure for no less than 5 days before installing and tensioning the cables.

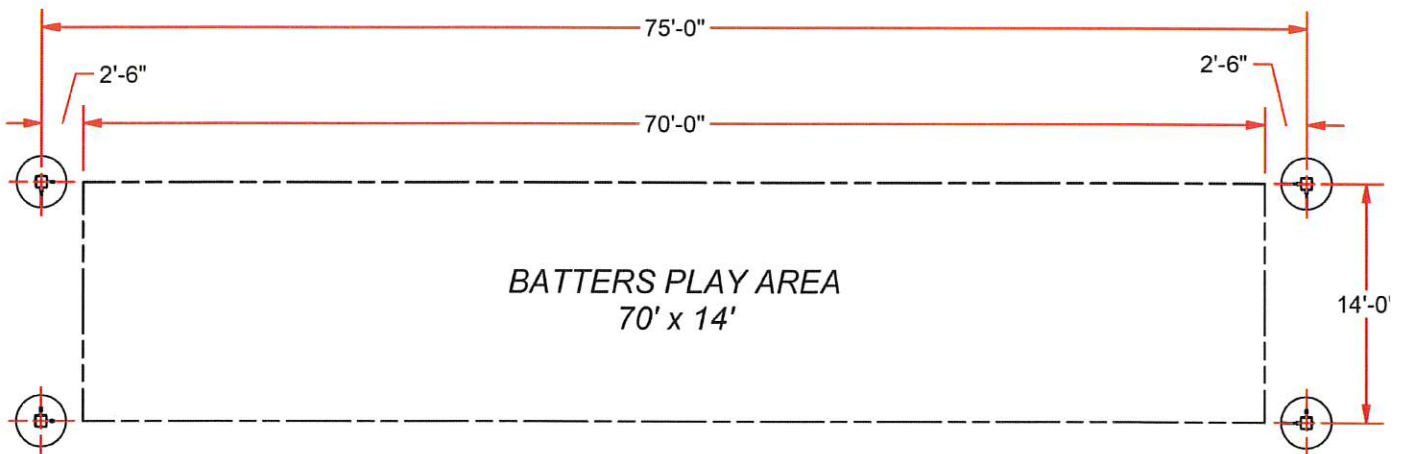
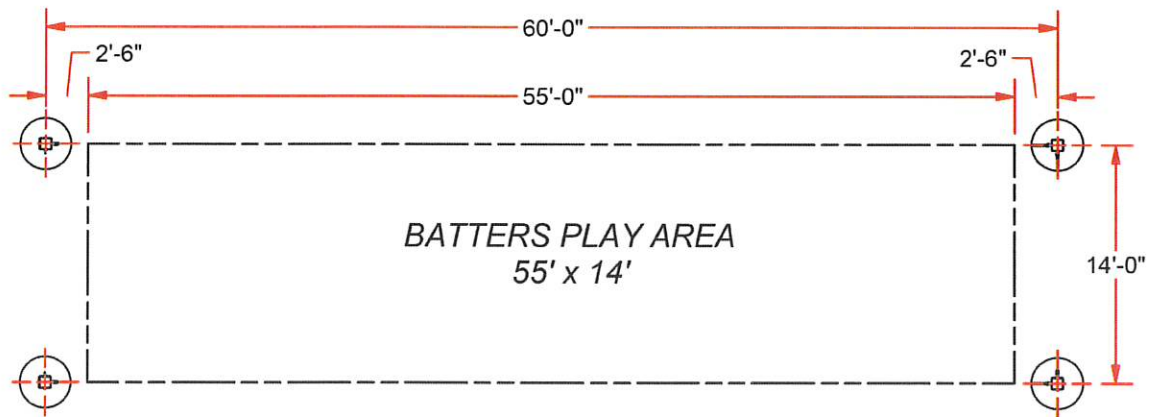

Figure 1

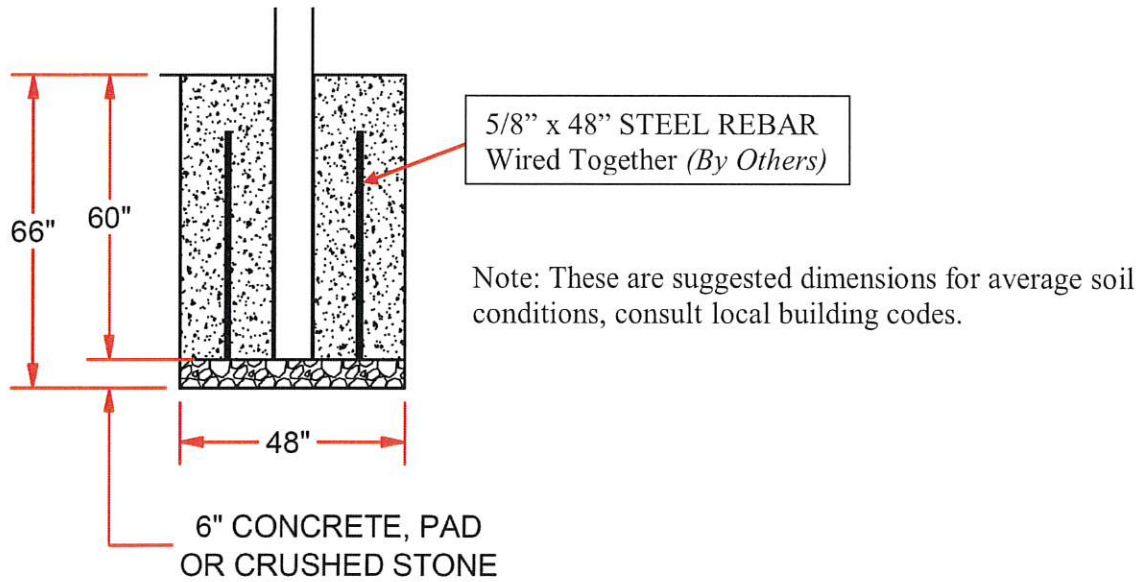

Figure 2

- **Before Digging**, Contact your local utility companies to locate buried electrical, gas, and water lines. Check for overhead utilities.
- Check local building codes before starting the footing, as building codes may vary. Local building codes should be adhered to if requirements are greater than those outlined here.
- Allow the concrete to fully cure, for no less than 5 days before installing tension cables.

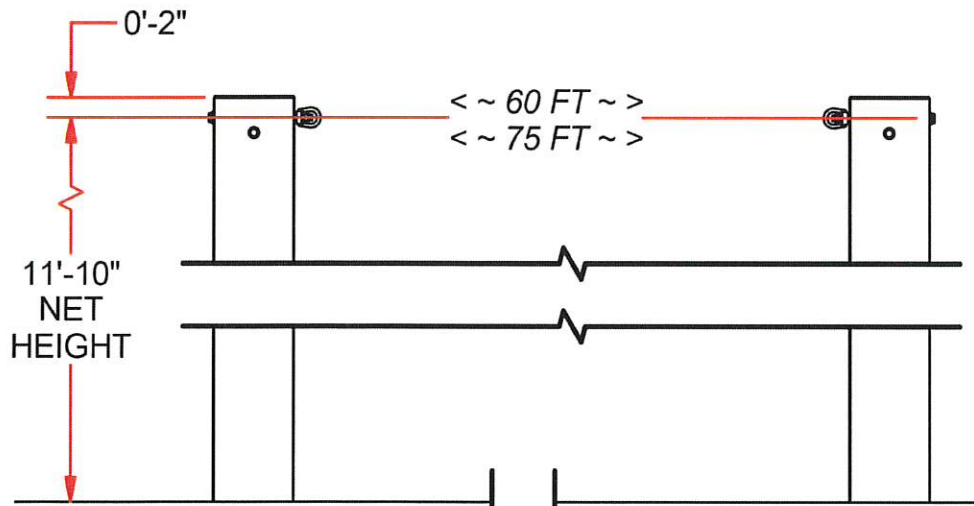

Figure 3

IMPORTANT: DO NOT POUR CONCRETE WITHOUT VERIFYING ORIENTATION OF THE POST HOLES. ENSURE THAT YOUR POST AGREES WITH FIGURE 3

II. Assembly:

Note: See Details A, B & C.

- 1) Make up the ends of the cable as shown in figure 4 of the 1/4" aircraft cable using thimbles & cable clamps. Note proper cable clamp positioning. Tighten the clamps on one end, but leave the other end somewhat loose to enable adjusting. Do not trim the cable yet. The cables should measure roughly 57'-10" or 72'-10" from thimble to thimble.
- 1) Install hardware on each pole as shown in Detail A, B & C. Each side of tunnel should consist of quick-link on one end and turnbuckle on the other (see Detail B). Extend the turnbuckles to their maximum length.
- 2) Attach the made up cable to the poles, attaching the fixed end of each cable to the quick-link and the free end to the turnbuckle. Lightly loosen the cable clamps and draw in the slack cable, pulling it as tight as you can. Tighten down the cable clamps and draw the cable tight using the turnbuckles. Repeat this step for all cables.
- 3) Roll out the net inside the frame. Center it and spread it out flat. Locate the rope border that runs along the top edge and down the center of the net.
- 4) Starting at one end, hang the net from the cables using the snap hooks, spaced approximately every 3'.
- 5) Once the net is completely hung tie off both ends using the rope leads extending from the net. Tie the net corners to the eye nuts on the posts. Position the net so it is centered from end to end.
- 6) Lastly, tie off the center rope to the cross cable, one each end, as shown in Detail C.

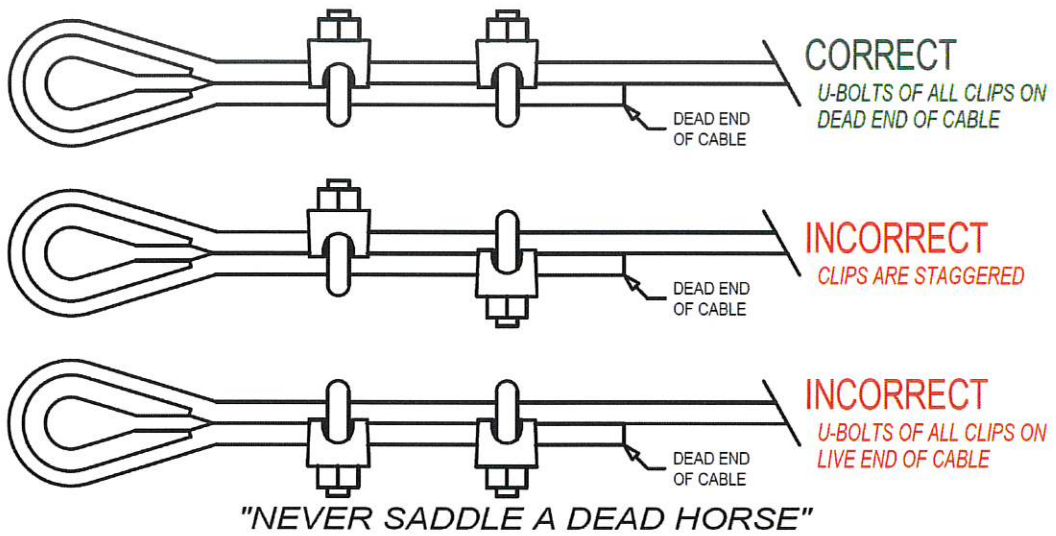
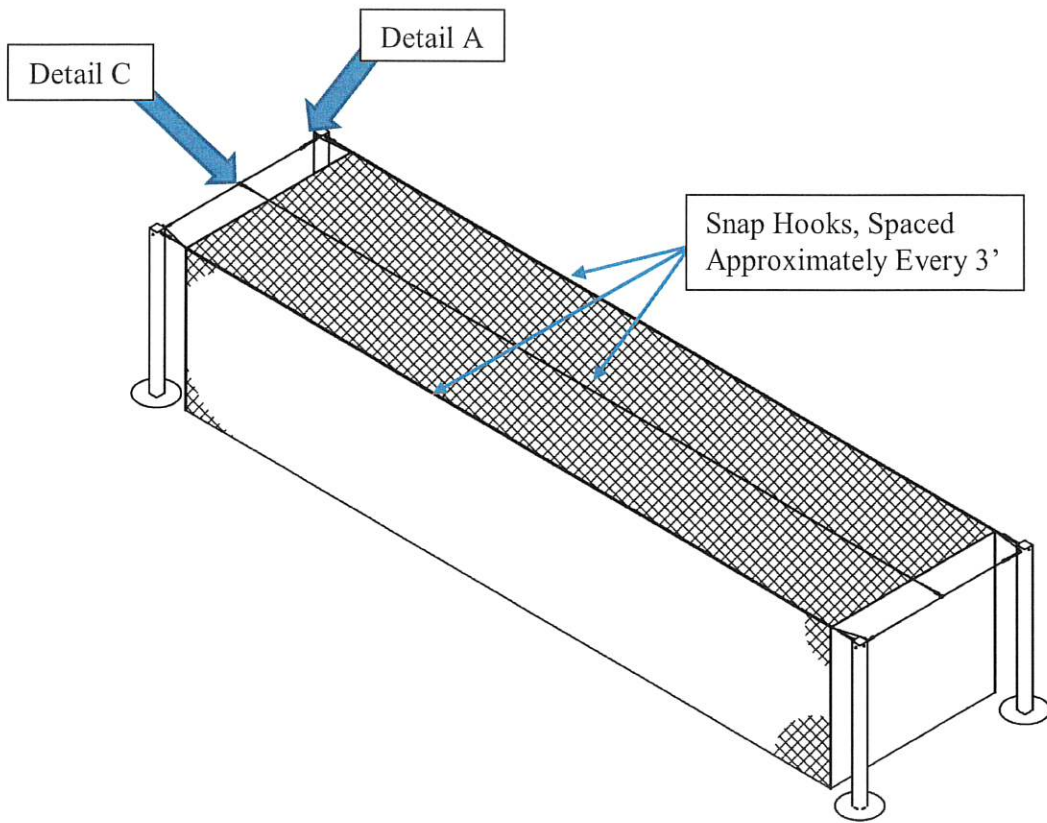
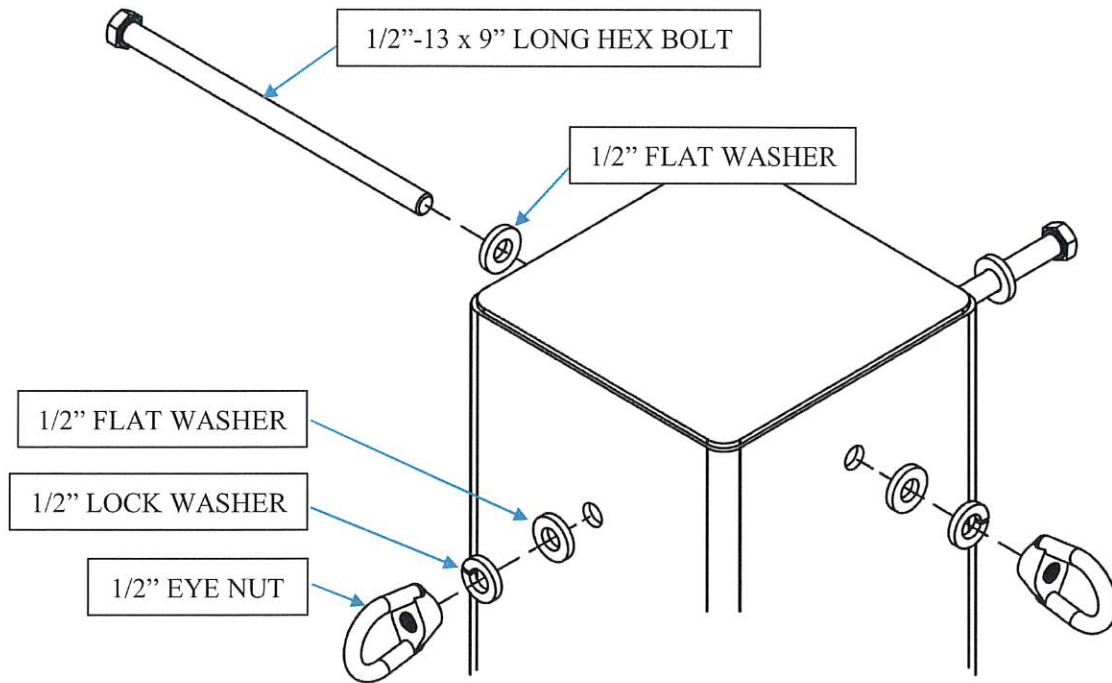
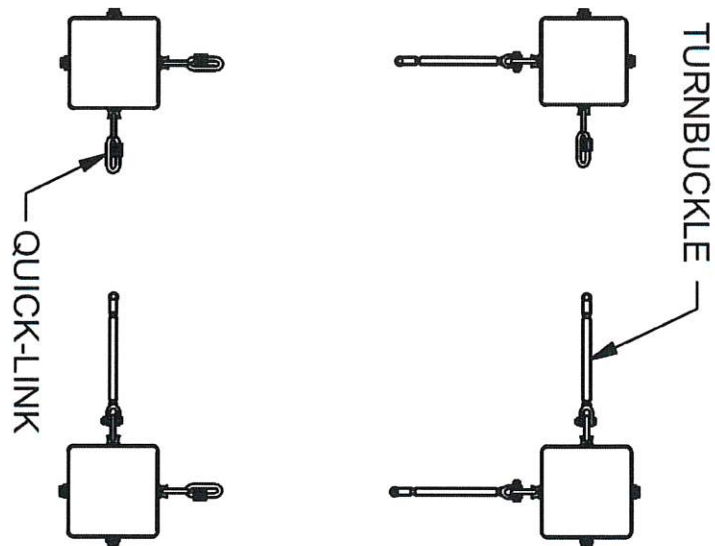

Figure 4



Detail A Typical Corner Post



Detail B Plan View of Quick-Link & Turnbuckle

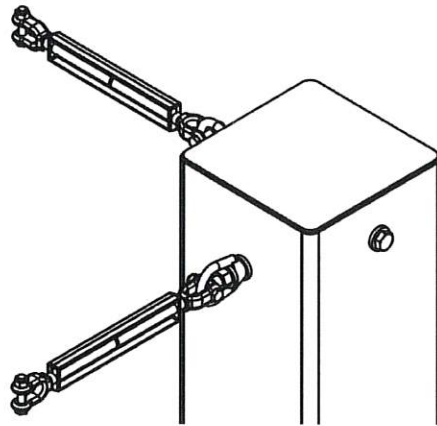

Typical Corner Assembly
SEE DETAIL B

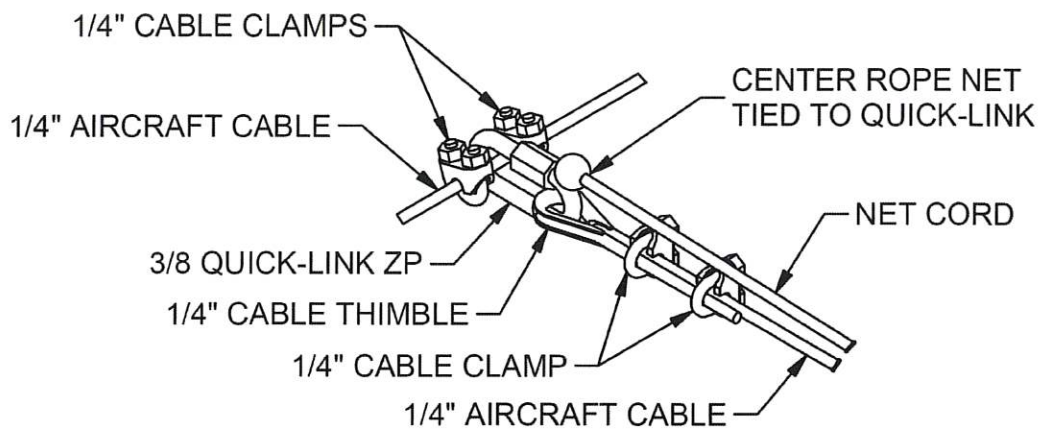

Detail C at center of net.

MPCTF-70D MEGA POST & CABLE OUTDOOR BATTING TUNNEL

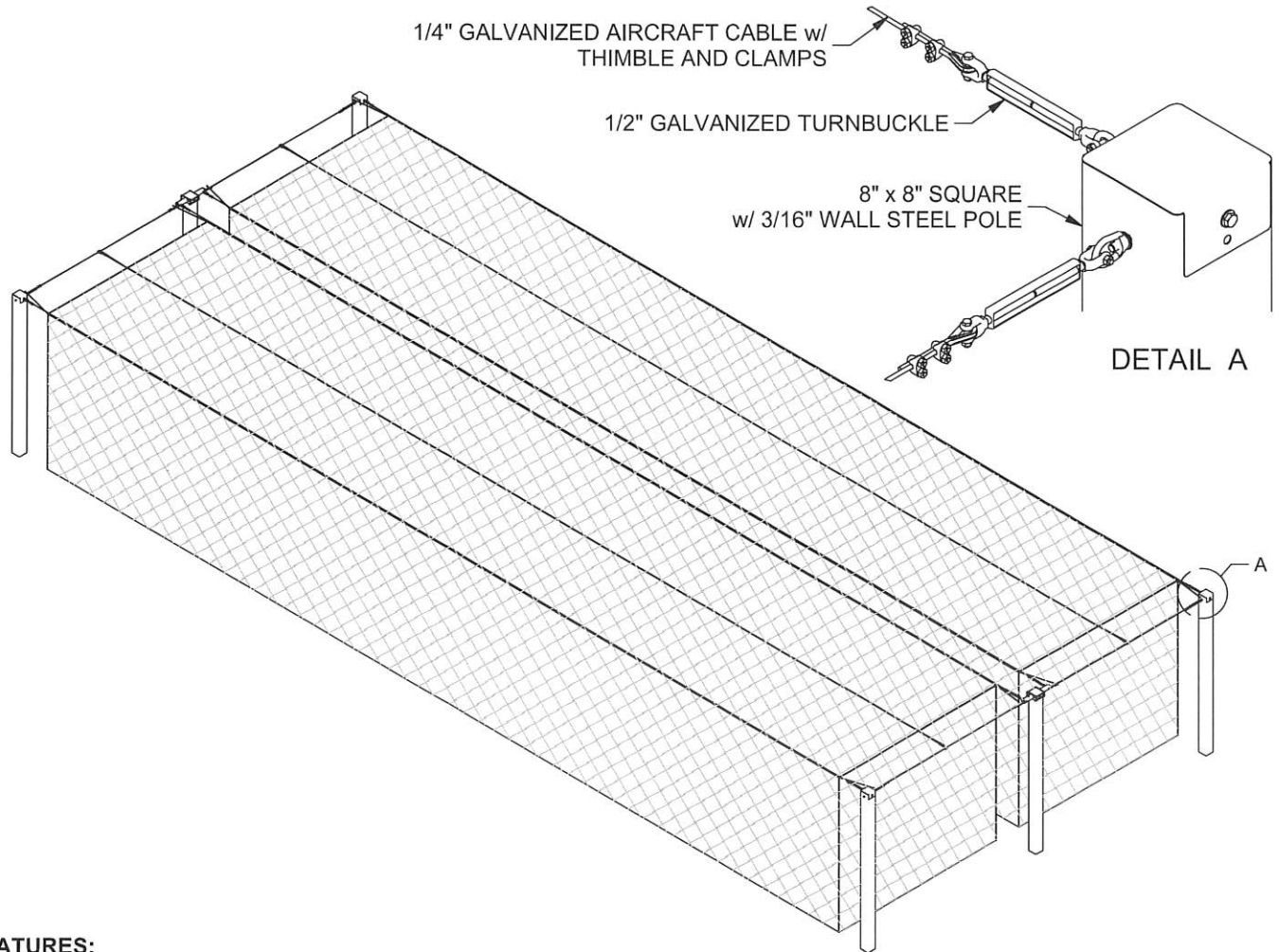

FEATURES:

- > CLEAN DESIGN WITH LESS STRUCTURE FOR BALL TO RICOCHET OFF.
- > 6 HEAVY WALL 8" x 8" SQUARE w/ 3/16" WALL STEEL POLES.
- > FINISH: POWDER COAT BLACK OVER ZINC PRIMER.
- > NET ATTACHES TO TENSIONED 1/4" GALVANIZED AIRCRAFT CABLE.
- > NET ATTACHED w/ SNAP HOOKS FOR EASY ON / OFF.
- > NET CAN BE EASILY SLID TO ONE END FOR STORAGE.
- > NET TO BE #36 BLACK KNOTTED NYLON, 1-3/4" SQUARE MESH, 14' W x 70' L x 12' H

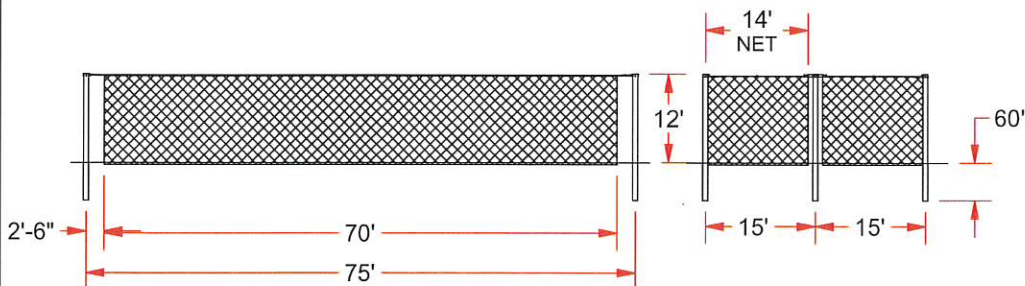
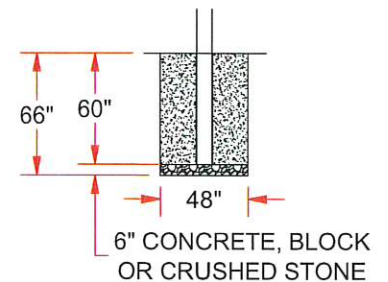

NOTE: SUGGESTED FOOTING, CHECK LOCAL BUILDING CODES BEFORE STARTING THE FOOTING, AS BUILDING CODES MAY VARY. LOCAL BUILDING CODES SHOULD BE ADHERED TO IF REQUIREMENTS ARE GREATER THAN THOSE OUTLINED HERE.



MPCTF-70D

MEGA POST & CABLE OUTDOOR BATTING
TUNNEL 70 FT LONG CAGE

© COPYRIGHT 2022 JAYPRO SPORTS, LLC. ALL RIGHTS RESERVED THIS PRINT IS THE PROPERTY
OF JAYPRO SPORTS, LLC. AND MAY NOT BE REPRODUCED WITHOUT WRITTEN PERMISSION

www.jayprosports.com

(800) 243-0533

976 Hartford Turnpike

Waterford, CT 06385 USA

Rev: A

SHEET 1 OF 1

CENTER KIT FOR 70' ADD ON CAGE

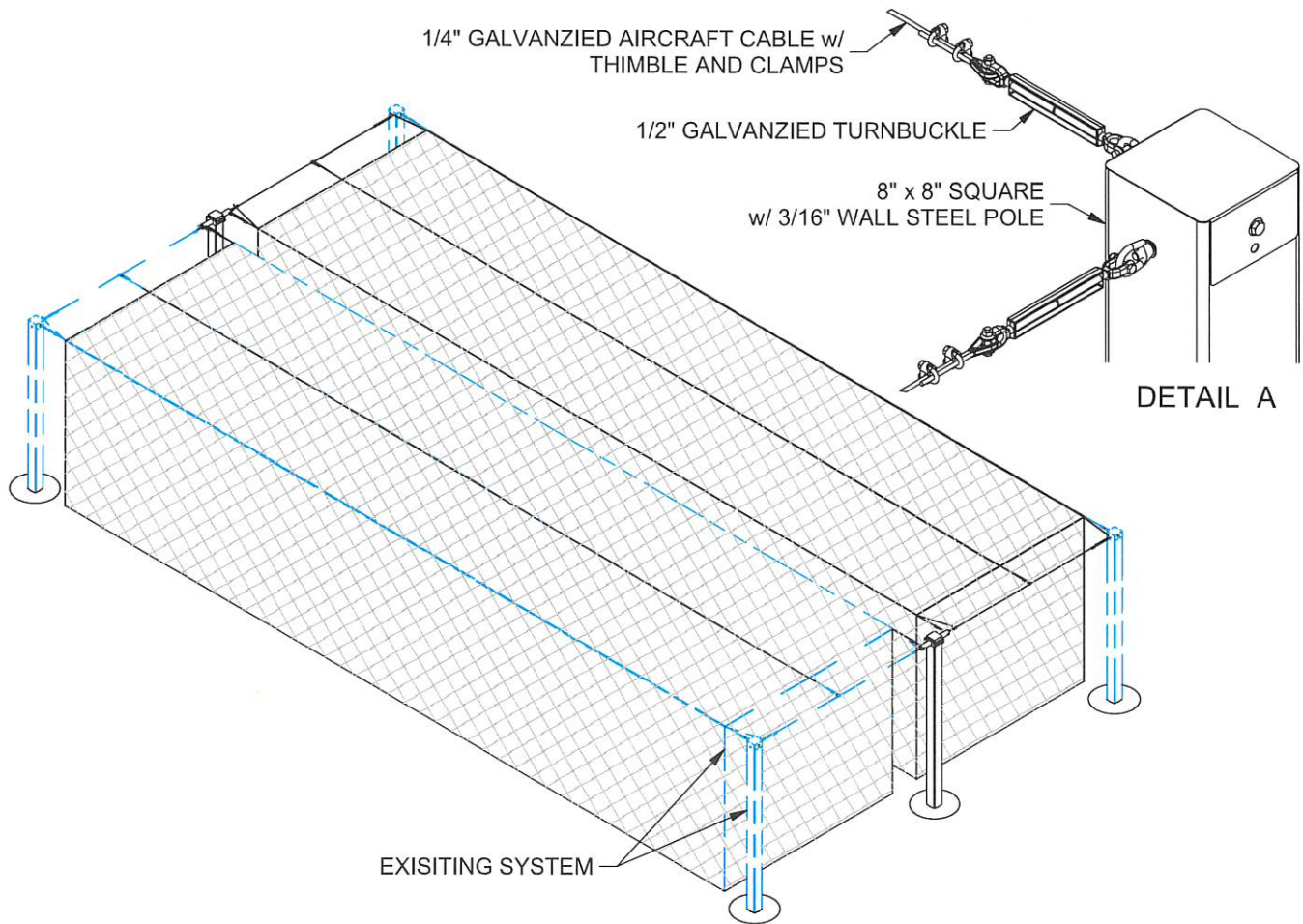

FEATURES:

- > CONVERTS SINGLE TUNNEL SYSTEM INTO TANDEM SYSTEM.
- > NET IS INCLUDED.
- > CLEAN DESIGN WITH LESS STRUCTURE FOR BALL TO RICOCHET OFF.
- > 6 HEAVY WALL 8" x 8" SQUARE w/ 3/16" WALL STEEL POLES.
- > FINISH: POWDER COAT BLACK OVER ZINC PRIMER.
- > NET ATTACHES TO TENSIONED 1/4" GALVANIZED AIRCRAFT CABLE.
- > NET ATTACHED w/ SNAP HOOKS FOR EASY ON / OFF.
- > NET CAN BE EASILY SLID TO ONE END FOR STORAGE.
- > NET TO BE #36 KNOTTED NYLON, 1-3/4" SQUARE MESH, 14' W x 55' L x 12' H

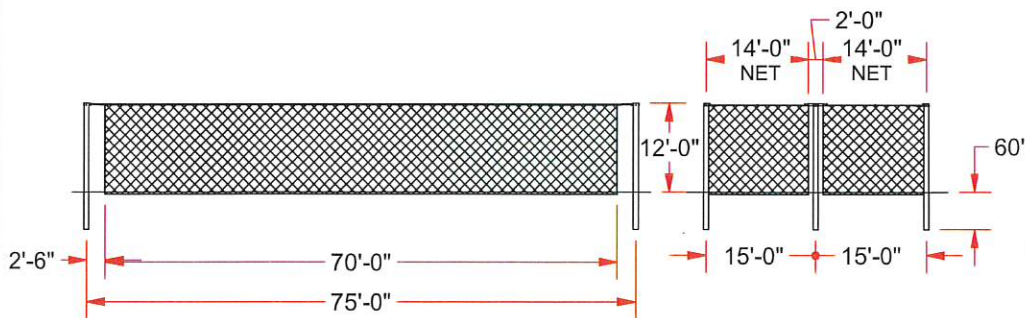
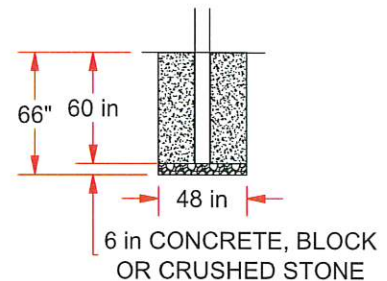

NOTE: SUGGESTED FOOTING, CHECK LOCAL BUILDING CODES BEFORE STARTING THE FOOTING, AS BUILDING CODES MAY VARY. LOCAL BUILDING CODES SHOULD BE ADHERED TO IF REQUIREMENTS ARE GREATER THAN THOSE OUTLINED HERE.



MPCTF-70A

CENTER KIT FOR 70' ADD ON CAGE

© COPYRIGHT 2020 JAYPRO SPORTS, LLC. ALL RIGHTS RESERVED THIS PRINT IS THE PROPERTY OF JAYPRO SPORTS, LLC. AND MAY NOT BE REPRODUCED WITHOUT WRITTEN PERMISSION

www.jaypro.com

(800) 243-0533
976 Hartford Turnpike
Waterford, CT 06385 USA

Rev: A

SHEET 1 OF 1

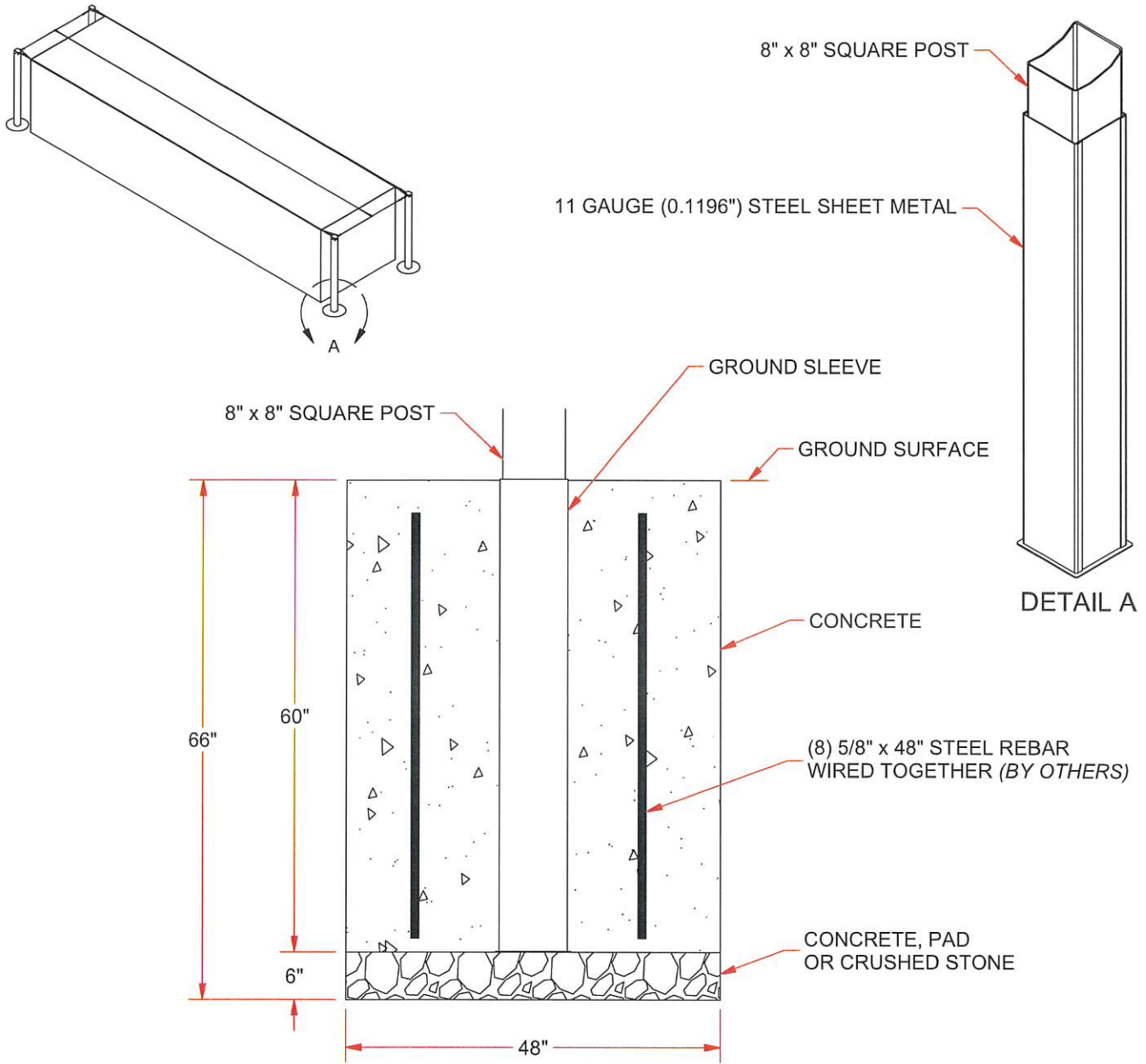

FEATURES:

- Heavy duty ground sleeve for 8" square Mega Outdoor Batting Tunnel Systems (MPCTF)
- Steel construction with bottom base plate (shipping weight 69 lbs each)
- Sold individually



Know what's below.
CALL BEFORE YOU DIG.

WARNING: Check Local Building Codes Before Installing Foundation

The dimensions provided are based on typical soil conditions and are for general guidance only. Before beginning any footing installation, consult your local building codes, as requirements may vary by location. If local codes specify stricter standards, those must be followed. Always ensure your installation is safe, legal, and fully code-compliant.



MPCTF-G
MEGA OUTDOOR BATTING TUNNEL GROUND SLEEVE

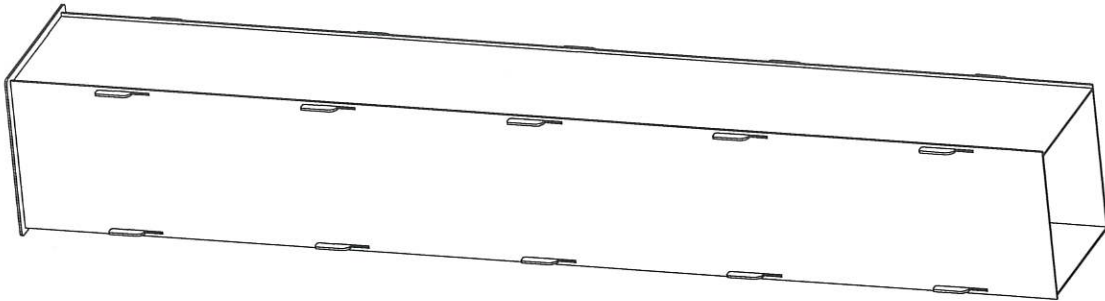

Installation and Maintenance Manual

Call Jaypro Sports at 1-800-243-0533 during
regular business hours for technical support.

www.jayprosports.com

MEGA OUTDOOR BATTING TUNNEL GROUND SLEEVE

IMPORTANT NOTES:

Ground sleeves are recommended to help facilitate.

Excavate foundations in accordance with site specific foundation designs. Site specific engineered foundations are recommended.

*If installing ground sleeves make sure sleeves are plumb. The top of the sleeve should be approximately level finish the finished grade.

*If installing poles without sleeves, allow concrete to cure no less than 5 days before proceeding.

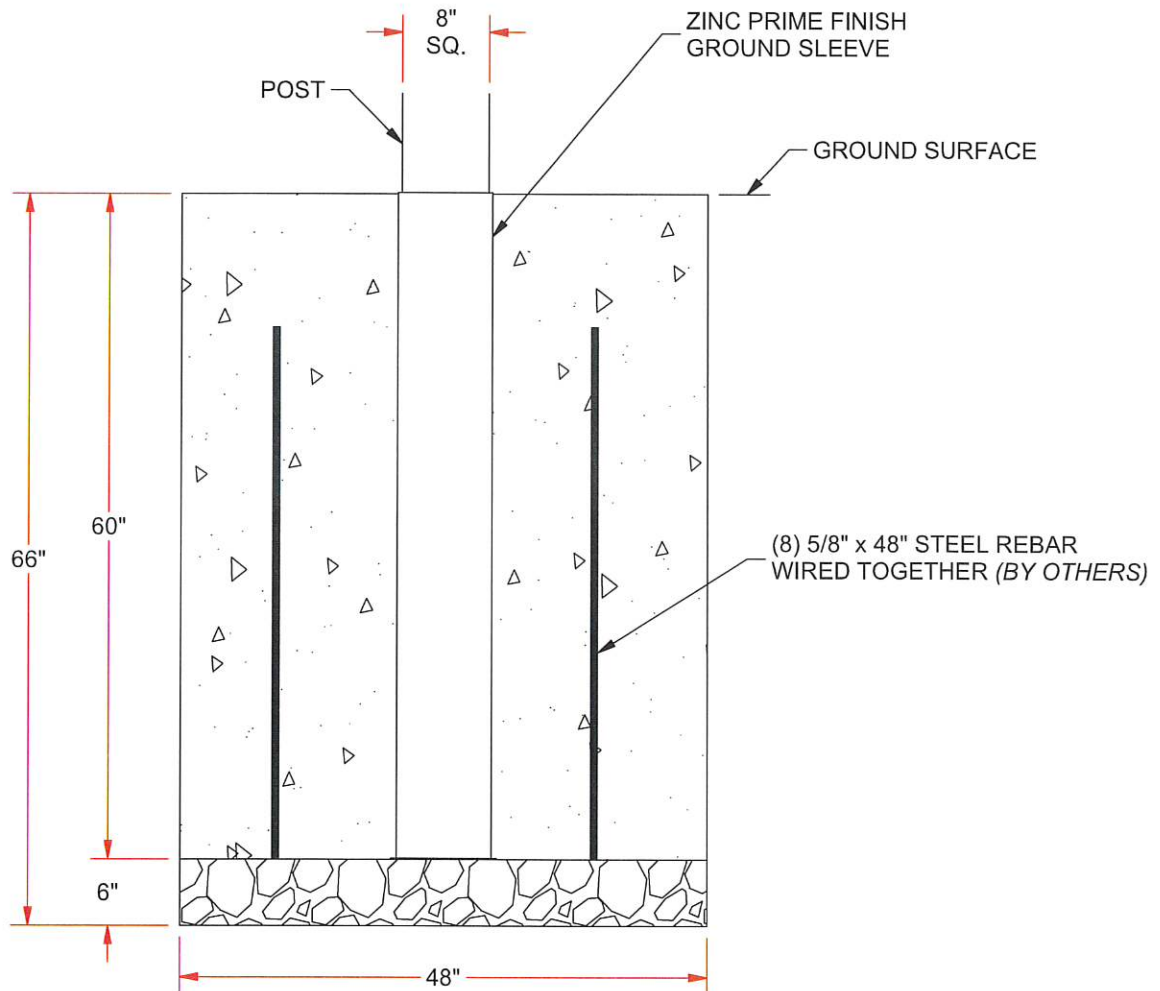

Ground Sleeve Installation:

1. Place the ground sleeve into the footing and fully support it so it's plumb in all directions.
2. Pour the foundations using 4,000 psi (min) concrete.
3. Slope the top of the footing away from the sleeve for proper drainage. Allow it to cure for no less than 5 days.
4. Install the pole into the sleeve. Pay close attention to its orientation with respect to the top brackets.



MPCTF-GS

www.jayprosports.com / (800) 243-0533 / 976 Hartford Tpke, Waterford, CT 06385 USA

SUBJECT TO CHANGES IN DESIGN AND MANUFACTURING
© COPYRIGHT 2024 JAYPRO SPORTS, LLC. ALL RIGHTS RESERVED

Sheet 2 of 2



34'

Concrete Slab Detail:

- *3000 PSI concrete with 2 lbs/yd macrosynthetic fibers
- *Slope from center of slab to outside edge @ .75%
- *Minimum slab depth to be 3.5"
- *Posts to be set prior to pouring slab, per detail.

80'

34'

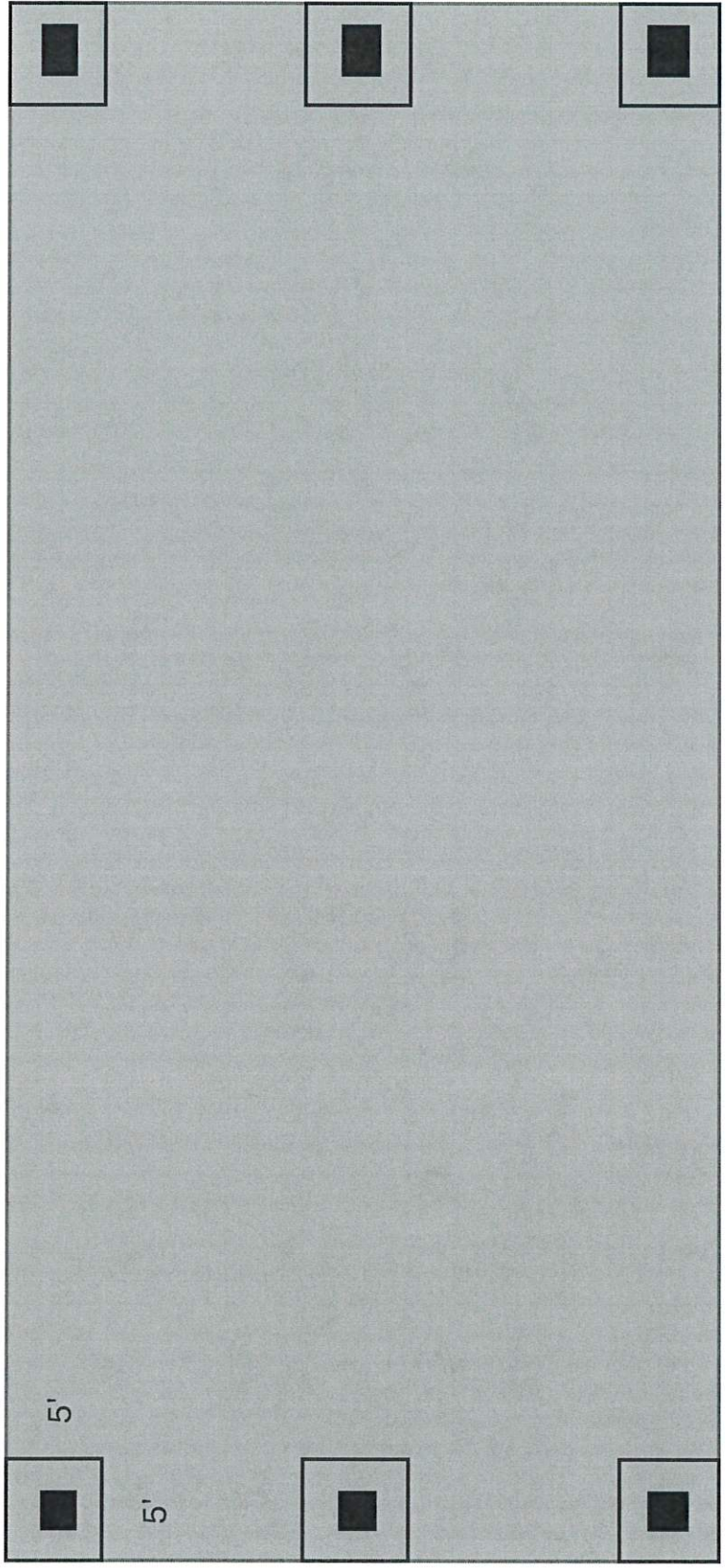

5'

5'

Synthetic Turf Detail:

Product: Turf Distributors ECO 85 Silver Putt, or equivalent.

* Install synthetic turf under the perimeter of each net. Approximate size to be 70' x 14'.

* Attach to concrete using turf adhesive, per manufacturer's specifications

70'



14'



Eco 85 Silver Putt

16-Year Product Warranty 

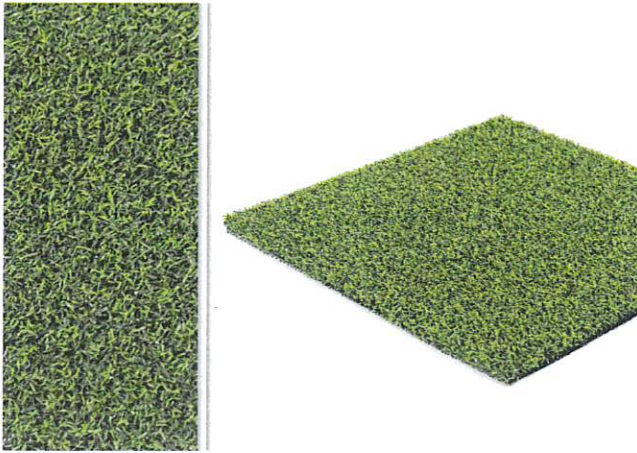

Yarn Type	Textured Polypropylene
Denier	PP 5500
Pile Height	~0.7"
Machine Gauge	3/16"
Roll Size	15' x 100'
Infill Amount	~0.5-1 lb / SqFt
Primary Backing	Polyurethane
Product Weight	~58 oz
Pile Yarn Weight	~31 oz
Average Tuft Bind Strength	96.8 lbs of Force
Total Lead Content	<0.5 mg / kg
Pill Flammability	8 Out of 8 Pass
Water Permeability	~112.1" per Hour
QUV Accelerated Weathering	Color: 10 / Texture 10



Recommended Uses

- Putting Greens
- Driving Ranges
- Mini-Golf Courses
- Patios or Rooftops

Stimp Speed: 8.5

Eco 85 Silver Putt has a ball roll performance like a professional green while still remaining budget friendly. This artificial putting green can be used both indoors and outdoors. No matter where you use it, the two-tone flower and lime green coloring will make for an attractive look.

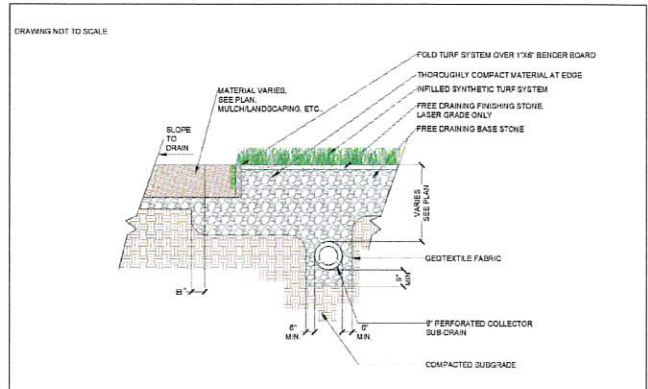

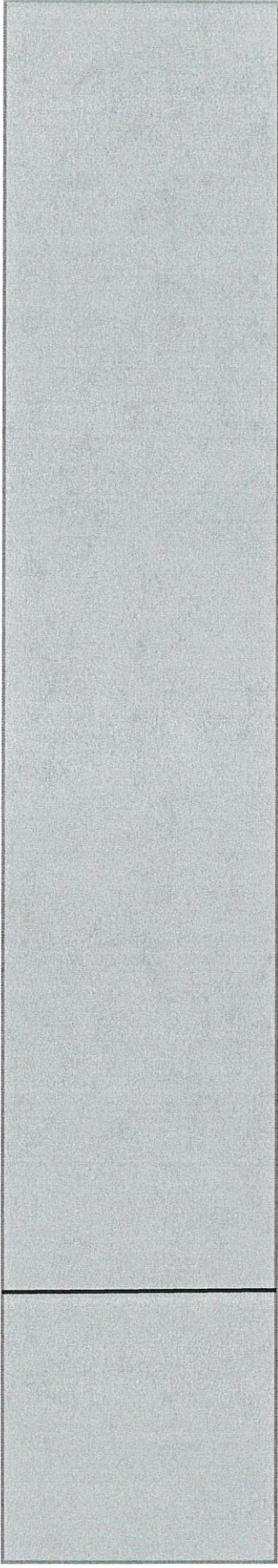

Sidewalk

- 5' wide
- ADA slope max of 5%, 1:20
- 3000 PSI w/ 2 lbs fiber/cubic yard
- Control joints @ 5' OC
- Provide costs per square foot installed

GENERAL CONDITIONS

INDEX TO GENERAL CONDITIONS

<u>SECTION</u>	<u>TITLE</u>	<u>PAGE</u>
01	Definitions of Terms	GC-2
02	Applicable Requirements	GC-3
03	Notice & Service Thereof	GC-4
04	Intent of Drawings and Specifications	GC-4
05	Present Documents Govern	GC-5
06	Instructions, Minor Changes, Etc.	GC-5
07	Examination of Work by Contractor	GC-5
08	Materials, Services and Facilities	GC-6
09	"Or Equal" Clause	GC-6
10	Testing of Materials	GC-7
11	Inspection of Work By Other Parties	GC-7
12	Authority of the Designer/Engineer	GC-7
13	Prohibited Interests	GC-8
14	Rejections of Work and Materials, and Owner's Right to Do Work	GC-8
15	Royalties and Patents	GC-8
16	Contractor's Superintendence and Personnel	GC-8
17	Permits, Licenses, and Impact Fees	GC-9
18	Laws and Regulations	GC-9
19	Subcontracting	GC-9
20	Subcontractors	GC-10
21	Assignments	GC-10
22	Insurance Requirements	GC-10
23	Land and Rights-of-Way	GC-10
24	Protection of Work, Property and Persons	GC-10
25	Prior Use by the City	GC-11
26	Cleaning Up and Site Access	GC-12
27	Disposal of Waste Materials from Any Construction	GC-12
28	Changes in the Work	GC-12
29	Modifications and Price Proposals	GC-12
30	Time for Completion, Liquidated Damages and Time Extensions	GC-14
31	Weather Delay Time Extensions	GC-15
32	Payments to Contractor	GC-16
33	Stored Materials	GC-17
34	Payments Withheld	GC-17
35	Schedules, Reports and Records	GC-18
36	City's Right to Terminate	GC-18
37	Final Acceptance of Work and Final Payment	GC-18
38	Construction Inspection	GC-19
39	Quality Control	GC-19
40	Guarantee and Correction of Work	GC-20
41	Differing Site Conditions	GC-20
42	Warranty of Construction	GC-20
43	Contractor Evaluation	GC-21

1. DEFINITIONS OF TERMS

Wherever used in the Contract Documents, the following terms shall have the meanings indicated which shall be applicable to both the singular and plural thereof:

"Addenda" shall mean written or graphic instruments issued prior to the execution of the agreement, which modify or interpret the Contract Documents by additions, deletions, clarifications, or corrections.

"Architectural Supplemental Instructions" shall mean the information that allows an architect to provide additional instructions or make minor changes without having to re-work the entire construction plan.

"Authorization Request" shall mean the final action in approving a cost or change event. It may result in a change in the project's cost of work, general conditions or overheads, contingency, or other item which is included in the contract amount.

"Bad Weather Day" shall mean a day when construction Work cannot be performed and is attributable to unusual weather phenomena as defined herein.

"Bid" shall mean the offer or Proposal of the Bidder submitted on the prescribed form setting forth the price(s) for the Work to be performed.

"Bidder" shall mean any person, firm, or corporation submitting a Bid for the Work.

"Bonds" shall mean Bid, Performance, and Payment Bonds and other instruments of security, furnished by the Contractor and his surety in accordance with the Contract Documents.

"Change Order" shall mean the adjustment of the contract of time, or addition or deduction to the overall contract price. A Change Order shall be an amendment to the contract and requires approval by the City of Raleigh through the City Council or City Manager.

"Change Order Directive (COD)" shall mean an instrument used to provide written notice for the Contractor to proceed with the work directed by the Designer or Owner prior to issuance of a formal request for change proposal or change agreement by the Contractor.

"Consultant" shall be defined as the professional services firm employed by the City or Owner.

"Contract Documents" shall consist of Advertisement for Bids, Proposal, Bid Bond, Contract, Contract Performance Bond, Payment Bond, Instructions to Bidders, General Requirements, General Conditions, Supplementary Conditions, Technical Specifications, Certificates of Insurance, and Drawings and any other pertinent documents. The intent of these documents is to include all materials, appliances, tools, labor, and services of every kind necessary for the proper execution of the Work, and the terms and conditions of payment therefore. The Contract Documents shall be considered as one, and whatever is called for by any one of them shall be as binding as if called for by all.

"Contract Price" shall mean the total monies payable to the Contractor under the terms and conditions of the Contract Documents.

"Contract Time" shall mean the number of calendar days stated in the Contract Documents for the completion of the Work.

"Contractor" or "General Contractor" shall mean the individual, firm, or corporation undertaking the execution of the Work as an independent Contractor under the terms of the Contract and acting through his or its agents or employees.

"Cost or Change Event" shall mean a directive to perform work resulting from a proposed change. There may or may not be costs associated with the work. It is initiated as a proposal from the Contractor and sent to the Designer for review. If approved by the Designer, the Designer forwards it to the Owner as a recommendation from the Designer in the form of an Authorization Request.

"City" shall mean City of Raleigh.

"Designer" shall mean the professional architectural and/engineering firm and/or its subconsultants that are responsible for the project design and have placed their professional seals on the construction documents. Can also be noted as "Engineer".

"Drawings" shall mean the part of the Contract Documents, which show largely through graphical presentation the characteristics, design and scope of the Work to be performed and which have been prepared or approved by the City.

"Final Acceptance" shall be defined as concurrence between the Designer and the Owner to accept the project from the contractor. Final acceptance of the project shall not be considered before the final inspection is conducted. Final acceptance does not infer the lack of claims on a project.

"Liquidated Damages" shall mean the amount reasonably estimated in advance to cover the consequential damages associated with the City's economic loss in not having the use of the project for its intended purposes resulting from the Contractor's failure to complete the project by the completion date.

"Modification" shall mean the process of incorporating agreed changes or alterations made to a contract. A contract modification may introduce, revise or cancel specifications, delivery period, price, quantity or terms of an existing contract, while leaving its overall purpose and effect intact.

"Notice of Award" shall mean the written notice to the successful bidder of the acceptance of the bid as approved by the City Council. Notice may be issued in person or via regular mail, certified mail with receipt of delivery, or email with receipt of delivery.

"Notice to Proceed" shall mean written communication issued by the City or its Designer to the Contractor authorizing him to proceed with the Work and establishing the date of commencement of the Work. Notice may be issued in person or via regular mail, certified mail with receipt of delivery, or email with receipt of delivery.

"Owner" shall mean City of Raleigh.

"Owner's Contingency" shall mean the amount of funds included in the contract that represents the Owner's best estimate of funds to provide for allowances and to address unforeseen circumstances or other conditions that may arise during the construction of the project.

"Project" shall mean the undertaking to be performed as provided in the Contract Documents.

"Project Manager" shall be the individual or individuals assigned to coordinate the project and insure that City procedures are followed, and the quality of Work is up to the standards expected.

"Request for Proposal" shall mean an offer by a contractor, in response to a request issued by the Designer or Owner for the purpose of requesting an equitable adjustment for a proposed change to an existing contract.

"Shall" is mandatory; "may" is permissive.

"Shop Drawings" shall mean all drawings, diagrams, illustrations, brochures, schedules, and other data, which are prepared by the Contractor, Subcontractor, manufacturer, Supplier, or distributor, which illustrate how specific portions of the Work shall be fabricated or installed.

"Specifications" shall mean a part of the Contract Documents consisting of written descriptions of a technical nature of materials, equipment, construction systems, standards, and Workmanship specified for this Project.

"Subcontractor" shall mean an individual, firm, or corporation having a direct contract with the Contractor or with any other Subcontractor for the performance of a part of the Work at the site.

"Substantial Completion" shall mean that date determined by the City when the construction of the Project or an expressly stipulated part thereof is sufficiently completed, in accordance with the Contract Documents, so the Project or stipulated part can be fully utilized for the purposes for which it is intended.

"Supplemental General Conditions" shall mean a part of the Contract Documents consisting of modifications or additions to the General Conditions.

"Superintendent" shall mean the Contractor's authorized on job representative designated in writing by the Contractor prior to commencement of any Work

"Supplier" shall mean any person, supplier, or organization who furnishes materials or equipment for the Work, including that fabricated to a special design, but who does not perform labor at the site.

"Surety" shall mean the bonding or insurance company that represents the Contractor and that assumes responsibility for the completion of the project should the Contractor, for any reason, become unable to complete the project.

"Time Extension" shall mean an increase in the length of time specified in a contract resulting in a revised contract completion date.

"Work" of the Contractor or Subcontractor shall include all labor, material, equipment, transportation, skill, tools, machinery, and other equipment and things useful or necessary in order to complete the Contract.

"Written Notice" shall mean the notification either in handwritten, computer generated, typed, or email form that communicates information or directives.

2. APPLICABLE REQUIREMENTS

The Work shall comply with the Contract Documents and with all applicable codes, laws, and regulations of the City, State, or Federal agencies. In the event of any conflict between the terms of this

Contract and such codes, laws, and regulations, the codes, laws, and regulations shall prevail. If the Contractor performs any Work contrary to such codes, laws, or regulations he shall assume full responsibility therefore and shall bear any and all costs necessary to correct the Work.

3. NOTICE AND SERVICE THEREOF

Any notice to Contractor from the City relative to any part of this Contract shall be in accordance with the City's Form of Contract.

4. INTENT OF DRAWINGS AND SPECIFICATIONS

The intent of the Drawings, Specifications/project manual and all other documents comprising the Contract Documents, is that the Contractor shall be held responsible to provide and pay for all labor, materials, tools, power, water, equipment, transportation, and other facilities necessary for the proper execution of the Work in accordance with the Contract Documents and all incidental Work necessary to complete the Project in an acceptable manner, ready for use, occupancy, or operation by the City.

The Drawings, Specifications/project manual, and all other documents comprising the Contract Documents, shall be supplementary to each other, and any material, Workmanship, and/or service which may be in one, but not called for in the others, shall be as binding as if indicated, called for, or implied by all. In case of discrepancy or disagreement in the contract documents, the order of precedence shall be: Form of Construction Contract, General Conditions, Supplemental General Conditions, Project Special Conditions, Technical Specifications, large-scale drawings, and small-scale drawings.

Any discrepancies found between the Drawings and Specifications and site conditions or any inconsistencies or ambiguities in the Drawings or Specifications shall be immediately reported to the Designer for the City, in writing, who shall promptly correct such inconsistencies or ambiguities in writing. Work done by the Contractor after his discovery of such discrepancies, inconsistencies, or ambiguities shall be done at the Contractor's risk.

Each section or type of Work is described separately in the Technical Specifications. For convenience of reference and to facilitate the letting of contracts and subcontracts, these Specifications are separated into titled sections. Such separation shall not, however, operate to make the City an arbiter to establish limits to the contracts between the Contractor and Subcontractors, nor shall such separation be interpreted as superseding normal construction trade jurisdictions. Should any item of material, equipment, Work, or combinations of such be required in one section, and not be described in that section and a similar item described in another section, that description shall apply regardless of the section under which it is described. In case of conflict between the Drawings and Specifications, the Specifications shall govern. Figure dimensions on Drawings shall govern over scale dimensions, and detailed drawings shall govern over general drawings.

Attention is directed to the fact that the detailed Specifications and separate sections may be written in short or abridged form. The Contractor shall, in regard to every section of the Specifications and Drawings of articles, materials, operations, or methods:

1. Provide each item mentioned and indicated, of quality or subject to qualifications noted.
2. Perform according to conditions stated, each operation prescribed.
3. Provide therefore all necessary labor, equipment and incidentals.

Whenever in these Specifications or on the Drawings the words "directed," "required," "permitted," "ordered," or words of like import are used, it shall be understood that the direction, requirement, permission or order of the City is intended, and similar words, "approved," "acceptable," "satisfactory," or words of like import shall mean approved by, acceptable to, or satisfactory to the City.

Notwithstanding the appearance of such language in the various sections of the Specifications as, "The Paving Contractor," "The Grading Contractor," etc., the Contractor is responsible to the City for the entire Contract and the execution of all Work referred to in the Contract Documents.

The Designer for the City may (without changing the scope of the Work) furnish the Contractor additional instructions and detail drawings, as necessary to carry out the Work required by the Contract Documents. The additional drawings and instructions thus supplied will become a part of the Contract Documents. The Contractor shall carry out the Work in accordance with the additional detail drawings and instructions.

5. PRESENT DOCUMENTS GOVERN

The Contractor shall in no case claim a waiver of any specification requirements on the basis of previous approval of material or Workmanship on other jobs of like nature or on the basis of what might be considered "standard" for material or Workmanship in any particular location. The Contract Documents for this job shall govern the Work.

6. INSTRUCTIONS, MINOR CHANGES, ETC.

All changes, alterations or instructions regarding any feature of the Work that differ from the Drawings and Specifications must be approved in writing in all cases, and no verbal orders will be regarded as a basis for claims for extra Work.

If the Contractor claims that any instruction by Drawings for a change or otherwise involves extra cost or an extension of time, he shall notify the Designer in writing within ten (10) days after the receipt of such instruction and, in any event, before proceeding to execute the Work. Thereafter, the procedure shall be the same as that described for changes in the Work. No such claim shall be valid unless made in accordance with the terms of this section.

No claims for extra cost will be considered based on an escalation of material prices throughout the period of the Contract.

No extra Work is to be performed or any change made that involves any extra cost or extension of time unless approved through an Authorization Request.

The Designer shall have authority, however to order minor changes in the Work not necessitating a cost event or change order, and not inconsistent with the intent of the Contract Documents. Such minor changes shall be affected by written order, bulletin drawing, or supplemental architectural instructions and shall be binding to the Owner and the Contractor.

7. EXAMINATION OF WORK BY CONTRACTOR

It is understood and agreed that the Contractor, has by careful examination, satisfied himself as to the nature and location of the Work, the conformation of the ground, the character, quality, and quantity of the facilities needed preliminary to and during the prosecution of the Work, the general and local conditions, and all other matters which can in any way affect the Work or the cost thereof under this Contract. No verbal agreement or conversation with any officer, agent, or employee of the City, either before or after the execution of the Contract, shall affect or modify any of the terms or obligations herein contained.

The Contractor shall, in good Workmanlike manner, do and perform all Work and furnish all supplies and materials, machinery, equipment, facilities, and means, except as herein otherwise expressly specified, necessary, or proper to perform and complete all the Work required by this Contract, within the time herein specified, in accordance with the provisions of this Contract and said Specifications and in accordance with the Drawings of the Work covered by this Contract and any and all supplemental drawings of the Work covered by this Contract. He shall furnish, erect, maintain, and remove such construction, plants, and such temporary Works as may be required. He alone shall be responsible for the safety,

efficiency, and adequacy of his plants, appliances, and methods, and for any damage, which may result from their failure or their improper construction, maintenance, or operation. The Contractor shall observe, comply with, and be subject to all terms, conditions, requirements, and limitations of the Contract and Specifications, local ordinances, and State and Federal laws; and shall do, carry on, and complete the entire Work.

The Contractor is and remains fully responsible for his own acts or omissions as well as those of any subcontractor or any employee of either. The Contractor agrees that no contractual relationship exists between the subcontractor and the Owner in regard to the Contractor and that the subcontractor acts on this Work as an agent or employee of the Contractor.

8. MATERIALS, SERVICES AND FACILITIES

The Contractor shall at all times employ sufficient labor and equipment for prosecuting the Work to full completion in the manner and time specified. Failure of the Contractor to provide adequate labor and equipment may result in default of the Contract. The labor and equipment to be used in the Work by the Contractor shall be sufficient to meet the requirements of the Work and shall be such as to produce a satisfactory quality of Work, in accordance with accepted industry practices within the time specified in the Contract.

If at any time during the construction and completion of the Work covered by these construction documents, the language, conduct, or attire of any Workman of the various crafts be adjudged a nuisance to the Owner or Designer, or if any Workman be considered detrimental to the Work, the Contractor shall order such parties removed immediately from the ground.

Materials and equipment shall be so stored and handled as to insure the preservation of their quality and fitness for the Work. Stored materials and equipment to be incorporated in the Work shall be located so as to facilitate prompt inspection. No product that has in any way become unfit for the intended purpose shall be incorporated into the Work.

Manufactured articles, materials and equipment shall be applied, installed, connected, erected, cleaned, and conditioned as directed by the manufacturer.

Materials, supplies, and equipment to be incorporated into the Work shall be new and unused unless otherwise specifically stated in the Contract Documents. The source of supply for all such products shall be submitted to the Designer, together with detailed descriptions thereof in the form of samples, Shop Drawings, tests, or other means necessary to adequately describe the items proposed. If, after trial, it is found that sources of supply, even though previously approved by the Designer, have not furnished products meeting the intent of the Contract Documents, the Contractor shall thereafter furnish products from other approved sources, and shall remove completed Work incorporating products which do not meet Contract requirements.

9. "OR EQUAL" CLAUSE

In accordance with G.S. 133-3, whenever a material or article required is specified or shown on the Drawings and/or Specifications by using the name of the proprietary product or of a particular manufacturer or vendor, the Designer shall denote that the quality standard of the article desired is the intent and the Contractor is not restricted to the specific brand, make, or manufacturer so named. The Designer shall specify three or more examples of items of equal or equivalent design. Any material or article that will perform adequately the duties imposed by the general design may be considered equal and satisfactory providing the material or article so proposed is of equal substance and function. The opinion of the Designer shall be final, and no substitute material or article shall be purchased or installed without such written approval.

Any proposed substitutions of materials, items, or equipment of equal or equivalent design shall be submitted to the Designer for approval or disapproval prior to the opening of bids. Proposed substitutions

shall only be submitted by the prime contractors. No requests from subcontractors, manufacturers or suppliers will be accepted.

10. TESTING OF MATERIALS

Unless otherwise specifically provided for, testing of materials and finished articles to be incorporated in the Work at the site shall be made by bureaus, laboratories, or agencies approved by the Designer and Owner. All laboratory tests shall be paid by the Owner unless provided otherwise in the contract documents. The Contractor shall furnish evidence satisfactory to the Designer that the material and finished articles have passed the required tests prior to the incorporation of such materials and finished articles in the Work.

The Contractor shall pay for the laboratory tests to establish design mixes for concrete, asphalt, mortar and other materials proposed for use on the project, and for additional tests to prove compliance with contract documents where materials have tested deficient except where the testing laboratory did not follow the appropriate testing procedures as defined in the Specifications.

11. INSPECTION OF WORK BY OTHER PARTIES

The Contractor shall, at all times, permit and facilitate inspection of the Work by authorized representatives of the City and authorities having jurisdiction in connection with the Work of this Contract. The presence or observations of the Designer or other City representatives at the site of the Work shall not be construed to, in any manner, relieve the Contractor of the responsibility for strict compliance with the provisions of the Contract Documents.

All Work shall be inspected by the Designer or the Owner's or its Consultants prior to being covered by the Contractor. The Contractor shall give a minimum of two weeks' notice unless otherwise agreed to by all parties. Not less than 48 hours prior to inspection or testing, the Contractor shall coordinate said events with the Designer, Owner, and/or respective parties. If the inspection fails after the first re-inspection, all costs associated with additional re-inspections, including travel, per diem, testing, etc. for the Designer or his authorized representative and the Owner's Consultants, shall be borne by the Contractor.

If the Specifications, City's instructions, laws, ordinances, or an authority having jurisdiction require any Work to be specially tested or approved, the Contractor shall give the Designer timely notice of its readiness for observation or inspection. If the inspection is by another authority, then the Designer shall be advised of the date fixed for such inspection. Required certificates of inspection shall be secured by the Contractor. Contractor having secured all certificates of inspection will deliver same to the Designer upon completion. If any Work should be covered up without approval or consent of the Designer, Project Manager, Special Inspector, it shall, if required by the Designer, be uncovered for examination at the Contractor's expense.

Should any disagreement or difference arise as to the estimate, quantities or classifications or as to the meaning of the Drawings or Specifications, or any point concerning the character, acceptability, and nature of the several kinds of Work, any materials and construction thereof, the decisions of the Designer shall be final and conclusive and binding upon all parties to the Contract.

12. AUTHORITY OF THE DESIGNER/ENGINEER

The Contractor shall perform all of the Work herein specified under the general direction, and to the entire satisfaction, approval, and acceptance of the Designer. The Designer shall decide all questions relating to measurements of quantities; the character of the Work performed and as to whether the rate of progress is such that the Work will be completed within the time limit of the Contract. All questions as to the meaning of these Specifications will be decided by the Designer.

The approval of the Designer of any materials, plants, equipment, Drawings, or of any other items executed, or proposed by the Contractor shall be construed only to constitute an approval of general design.

Such approval shall not relieve the Contractor from the performance of the Work in accordance with the Contract Documents, or from any duty, obligations, performance guarantee, or other liability imposed upon him.

Where drawings or specifications are sealed by the Engineer, in lieu of Designer, these same provisions shall apply to the Engineer.

13. PROHIBITED INTERESTS

No official of the City who is authorized in such capacity and on behalf of the City to negotiate, make, accept or approve, or to take part in negotiating, making, accepting, or approving any architectural, engineering, inspection, construction, or material supply contract, or any subcontract in connection with the construction of the Project, shall become directly or indirectly interested personally in this Contract or in any part hereof. No officer, employee, architect, attorney, engineer, or inspector of or for the City who is authorized in such capacity and on behalf of the City to exercise any legislative, executive, supervisory, or other similar functions in connection with the construction of the Project, shall become directly or indirectly interested personally in this Contract or in any part thereof, any material supply contract, subcontract, insurance contract, or any other contract pertaining to the Project.

14. REJECTIONS OF WORK AND MATERIALS, AND OWNER'S RIGHT TO DO WORK

All materials and equipment furnished, and all Work done that is not in accordance with the Drawings or Specifications or that is defective will be rejected. All rejected materials, equipment, or Work shall be removed immediately. If rejected materials, equipment, or Work is not removed within forty-eight hours from the date of letter of notification, the Designer shall have the right and authority to stop the Contractor and his Work immediately, and/or shall have the right to arrange for the removal of said rejected materials, equipment, or Work at the cost and expense of the Contractor. All rejected materials, equipment, or Work shall be replaced with other material, equipment, or Work that conforms with the Drawings and Specifications at no additional cost to the City.

Inspection of the Work shall not relieve the Contractor of any of his obligations to fulfill his Contract and defective Work shall be made good regardless of whether such Work, material, or equipment has been previously inspected by the Designer and accepted or estimated for payment. Neither the final certificate, final payment, occupancy of the premises by the Owner, nor any provision of the contract, nor any other act or instrument of the Owner, nor the Designer shall relieve the Contractor from responsibility for negligence or faulty material or Workmanship or failure to comply with the drawings and Specifications.

If during the progress of the Work or during the period of guarantee, the Contractor fails to prosecute the Work properly or to perform any provision of the contract, the Owner, after seven days' written notice sent in person or via email with delivery confirmation or certified mail, return receipt requested, to the Contractor from the Designer, may perform or have performed that portion of Work. The cost of the Work may be deducted from any amount due or to become due to the Contractor, including retainage, such action and cost of same having been first approved by the Designer. Should the cost of such action of the Owner exceed the amount due or to become due to the Contractor, then the Contractor or his surety, or both, shall be liable for and shall pay to the Owner the amount of said excess.

15. ROYALTIES AND PATENTS

The Contractor shall hold and save the City and its officers, agents, servants, and employees, harmless from liability of any nature or kind, including cost and expenses for, or on account of, any patented or unpatented invention, process, article, or appliance manufactured or used in the performance of the Contract, including its use by the City, unless otherwise specifically stipulated in the Contract Documents.

16. CONTRACTOR'S SUPERINTENDENCE AND PERSONNEL

The Contractor will supervise and direct the Work. He will be solely responsible for the means, methods, techniques, sequences, and procedures of construction. An experienced Superintendent, and

the necessary assistants competent to supervise the Work involved, shall be assigned to the Project by the Contractor and shall be present at the site when Work is in progress. The name of the Superintendent shall be submitted with qualifications of same prior to start of the Work and shall be approved by the Designer prior to start of the Work. The Superintendent so named by the Contractor shall be employed by the Contractor and shall have served in a supervisory capacity on at least one Project of like description and size performed by the Contractor during the previous twelve months. Under no circumstances shall an employee of any Subcontractor serve as Project Superintendent. The Superintendent shall represent the Contractor, and all directions given to the Superintendent shall be as binding as if given to the Contractor.

Only persons skilled in the type of Work that they are to perform shall be employed. The Contractor shall maintain discipline and good order among his employees and shall not employ on the Work any unfit person or persons or anyone unskilled in the Work assigned him. The Contractor shall insure that all employees maintain proper respect and courtesy for the any persons/individuals on the project site or in adjacent off-site areas.

17. PERMITS, LICENSES, AND IMPACT FEES

Permits and licenses of a temporary nature necessary for the prosecution of the Work shall be secured by the Contractor. Costs for permits, licenses, and impact fees may be included in the total contract amount as an allowance. Refer to the bid documents or Supplemental General Conditions.

18. LAWS AND REGULATIONS

The Contractor's attention is directed to the fact that all applicable Federal, State, and City laws, municipal ordinances, and the rules and regulations of all authorities having jurisdiction over construction of the Project shall apply to the Contract throughout, and they will be deemed to be included in the Contract Documents the same as though herein written out in full. The Contractor shall keep himself fully informed of all laws, ordinances, and regulations of the Federal, State, and City in any manner affecting those engaged or employed in the Work or the materials used in the Work or in any way affecting the conduct of the Work and of all orders and decrees of bodies or tribunals having any jurisdiction or authority over same. If any discrepancy or inconsistency should be discovered in this Contract, or in the Drawings or Specifications herein referred to, in relation to any such law, regulation, ordinance, order, or decree, he shall herewith report the same, in writing, to the Designer. The Contractor shall always observe and comply with all such laws, ordinances, and regulations, and shall protect and indemnify the City and its agents against any such law, ordinance, regulation, order, or decree, whether by himself or by his employees.

19. SUBCONTRACTING

The Contractor understands and agrees that it shall be a breach of this Contract to subcontract any portion of the Work on this Project unless the Work and the Contractor proposed to perform it have been declared in the Proposal to the Contract. Within thirty (30) days after award of the contract, the Contractor shall submit to the Designer and Owner a list giving the names and addresses of subcontractors, and equipment and material suppliers he proposes to use together with the scope of their respective parts of the Work. Should any subcontractor be disapproved by the Designer or Owner, the Designer or Owner shall communicate its decision to the Contractor. The Contractor shall present substitutions to the Designer and Owner for approval. If the subcontractor is listed on the MWBE affidavits, another MWBE subcontractor with similar certification/classification shall be substituted.

THE CONTRACTOR FURTHER UNDERSTANDS AND AGREES THAT ANY WORK ON THIS PROJECT WHICH THE CONTRACTOR SECURES IN VIOLATION OF THIS PROVISION SHALL BE DEEMED A GRATUITY FROM THE CONTRACTOR FOR WHICH THE CITY OF RALEIGH SHALL NOT BE OBLIGATED TO PAY. ALSO, THAT ANY WORK DONE BY THE SUBCONTRACTOR AND NOT MEETING THE SPECIFICATIONS SHALL BE THE RESPONSIBILITY OF THE CONTRACTOR TO REPLACE AT HIS OWN COST.

Nothing contained in this Contract shall create any contractual relation between any Subcontractor and the City.

20. SUBCONTRACTORS

Within seven (7) days after award of the construction contract, the Contractor shall submit to the Designer and to the Owner's Representative, a list giving the names and addresses of subcontractors they propose to use, together with the scope of work and their respective parts of the work.

The Designer may furnish to any subcontractor, upon written request, evidence regarding amounts of money requested to be paid to the Contractor regarding the portion of the subcontractor's work; provided however, that the Contractor has sufficiently broken down the request to allow such determination.

The Owner reserves the right to limit the amount of work, or the percentage of work, to be subcontracted as hereinafter specified.

21. ASSIGNMENTS

The Contractor shall not assign the whole or any part of this Contract or any monies due or to become due hereunder without written consent of the City.

22. INSURANCE REQUIREMENTS

Review the City of Raleigh Form of Contract and Supplemental Conditions for the specific insurance requirements.

23. LAND AND RIGHTS-OF-WAY

Prior to entering on any land or right-of-way, the Contractor shall ascertain the requirements of applicable permits or easements secured by the City or required of the Contractor and shall conduct his Work in accordance with requirements thereof including the giving of notice.

The Contractor shall provide at his own expense and without liability to the City any additional land and access thereto that the Contractor may desire for temporary construction facilities, or for storage of materials.

24. PROTECTION OF WORK, PROPERTY AND PERSONS

The Contractor will be required to protect all Work and materials against damage or injury from the weather. If, in the opinion of the Designer, any Work or materials shall have been damaged or injured by reason of failure to protect such, all such materials or Work shall be removed and replaced at the expense of the Contractor.

The Contractor will be responsible for initiating, maintaining and supervising all safety precautions and programs in connection with the Work. He will take all necessary precautions for the safety of, and will provide the necessary protection to prevent damage, injury or loss to all employees on the Work and other persons who may be affected thereby, all the Work and all materials or equipment to be incorporated therein, whether in storage on or off the site, and other property at the site or adjacent thereto, including trees, shrubs, lawns, lakes, drainage ways, walks, pavements, roadways, structures and utilities not designated for removal, relocation or replacement in the course of construction. Contractor shall provide continuously sufficient illumination at all barricades and at protective barriers around excavations so that the public is adequately warned of such hazards. The Contractor shall, where necessary, provide and maintain access to and from all adjacent properties as directed by the plans and Specifications, or the Designer, or the Owner's Representative, for street rights of way, along the line of his Work. He shall abide by the Manual on Uniform Traffic Control Devices (MUTCD) for any street closures or traffic control.

The Contractor will comply with all applicable laws, ordinances, rules, regulations and orders of any public body having jurisdiction. He will erect and maintain, as required by the conditions and progress of the Work, all necessary warning safeguards for devices and safety and protection of the Work, the public, and adjoining property. He will notify Owners of adjacent utilities when prosecution of the Work may affect them. The Contractor will remedy all damage, injury or loss to any property caused, directly or indirectly, in whole or in part, by the Contractor, any Subcontractor or anyone directly or indirectly employed by any of them or anyone for whose acts any of them may be liable.

The Contractor shall, prior to commencing other on-site Work, accurately locate above and below ground utilities and structures, which may be affected by the Work, using whatever means may be appropriate. The Contractor shall mark the location of existing utilities and structures, not otherwise readily visible, with flagging, stakes, barricades, or other suitable means, and shall preserve and protect all utilities and placement during construction. He shall notify the Designer promptly on discovery of any conflict between the Contract Documents and any existing facility.

In emergencies affecting the safety of persons or the Work or property at the site or adjacent thereto, or unanticipated conditions where delay would substantially impact the time or cost of Work, the Contractor, upon notification to the Designer, shall act to prevent threatened damage, injury, or loss. Any claim for compensation or extension of time by the Contractor due to such extra Work shall be submitted to the Designer within ten (10) days of the date of performing such Work or deviations in the manner prescribed for a cost event or change order. The Designer will evaluate and determine if the claims asserted by the Contractor warrant a cost event or change order and will make a recommendation to the Owner.

All existing utilities, both public and private, including sewer, gas, water, electrical, and telephone services, etc., shall be protected and their operation shall be maintained through the course of the Work. Any temporary shutdown of an existing service shall be arranged between the Contractor and the utility responsible and hold the City harmless from the result of any damage that may occur as a result of the Contractor's activities.

See the City's Form of Contract and the Supplementary Conditions for additional safety requirements.

25. PRIOR USE BY CITY

Prior to completion of the Work, the City may take over operation and/or use of the uncompleted Project or portions thereof. The Contractor must agree to the prior use, and it must not prevent the Contractor from completing the Work. Such prior use of facilities by the City shall not be deemed as acceptance of any Work or relieve the Contractor from any of the requirements of the Contract Documents.

Where the City has beneficial occupancy of a usable facility prior to the expiration of the specified Contract Time, but where contract Work items remain outstanding, the City, at its option, may, in lieu of all or a proportion of liquidated damages owed by the Contractor, charge the Contractor for actual cost of administering the Contract for a period subsequent to expiration of the Contract completion date (not to exceed the total amount which could be assessed under liquidated damages).

26. CLEANING UP AND SITE ACCESS

The Contractor shall at all times keep the premises free from accumulation of waste materials or rubbish caused by Contractor's employees or Work. Upon completion of the Work, the Contractor shall remove all his equipment, tools, materials, and other articles from the property of the City. Delivery of construction materials and equipment shall be only from locations approved by the City.

27. DISPOSAL OF WASTE MATERIALS FROM ANY CONSTRUCTION

Disposal of all waste material from construction sites shall be made in strict accordance with all State laws and City ordinances pertaining to disposal of construction or hazardous waste. It shall be the responsibility of the Contractor to secure the necessary permits and provide all information required to secure said permits. The Contractor shall designate the disposal site prior to beginning construction and in the event waste material is to be disposed of on private property, a letter from the property Owner shall be furnished to the Owner or its representative granting the Contractor or his agent(s) such permission and listing the requirements made by the property Owner on the Contractor, if any.

28. CHANGES IN THE WORK

The City may at any time, as the need arises, order changes within the scope of the Work without invalidating the agreement. If such changes increase or decrease the amount due under the Contract Documents or in the time required for performance of the Work, an adjustment may be authorized by a cost event or change order.

The Contractor must assert any request for an adjustment to the contract price, performance schedule, or both, in writing no later than 10 days from the Contractor's first knowledge of the change, or its right to assert such request for equitable adjustment shall be considered waived. Under no circumstance shall any pending request for adjustment or dispute excuse the Contractor from proceeding with its performance, as changed. The Owner, in its sole discretion, may receive and act upon any request for equitable adjustment at any time before final payment.

The Designer, also, may at any time, make changes in the details of the Work as may also be approved by the Owner. The Contractor shall proceed with the performance of any changes in the Work so ordered by the Designer unless the Contractor believes that such change entitles him to a change in contract price, time, or both, in which event he shall give the Designer written notice thereof within five (5) days after the receipt of the ordered change, and the Contractor shall not execute such changes pending the receipt of authorization from the Owner or the Designer.

29. MODIFICATION AND PRICE PROPOSALS (Form is attached at the end of the General Conditions)

The City may issue modification and price proposal requests for changes during the contract. The Contractor shall submit itemized price proposals including those for all subcontractors and sub-tiers for any such requests. The format used by the City for an adjustment in accordance with this term shall be a Request for Proposal (RFP). The Contractor's proposal shall be submitted within 10 days, or as otherwise directed by the Department, of the Contractor's first knowledge of the proposed change or receipt of the RFP. The City or Designer may also issue a Notice to Proceed associated with the request for proposal should it be determined to be in the City's best interest.

The proposal shall include a detailed breakdown of all labor, equipment, materials, supplies, overhead and profit costs for both the contractor and all subcontractors at any tier to allow a review of the proposal. Material, labor, equipment and other direct cost shall be summarized and totaled as construction direct costs in the proposal. Overheads, profit, and bond shall be added as appropriate line items shown as indirect or soft cost in the proposal. Cost estimates or pricing detail backup shall be completely itemized to include direct labor man-hours, individual craft, and hourly wage rate. Include verifiable labor burden (including craft fringes, FUI, SUI, and FICA) as a separate line item.

All subcontractor proposals shall include this same level of breakdown and detail and shall be so noted in the Contractor's proposal. The contractor shall provide copies of any quotations that have been received in regard to the proposal and shall ensure that adequate competition has been obtained such that the proposal is fair and reasonable. Any credit for deleted work shall also be reflected on the proposal.

Such proposal shall also include a detailed justification for any time extension request that is being requested as part of the equitable adjustment. Any time extension request that arise from the proposal shall be clearly noted, shall identify the specific activity or activities involved, and shall depict the changes necessary in the project schedule in order to accomplish the change. The contractor is advised that any request in contract period must demonstrate that there has been an increase in the critical path for completion of the project that is directly attributed to the change. The contractor shall provide a revised project schedule incorporating any time extension resulting as part of the equitable adjustment.

Lump sum cost estimates or price proposals shall be rejected and returned to the Contractor for itemization as described above. Failure of the Contractor to submit properly itemized cost estimates or price proposals shall not constitute an excusable delay. The equitable adjustment shall not include increased costs or time extension for delay resulting from the Contractor's failure to provide notice or to diligently continue performance. No proposal from the Contractor for an equitable adjustment shall be allowed if not asserted within time frames in this clause.

Following is a Sample Quotation Form for Cost Change Proposals:

Project:

Brief Description of Change:

1.	Materials / Products (itemized breakdown / quotes attached) Attach additional sheets as required.	\$ _____	1
2.	Owned Equipment (list each item separately)* Rental of Equipment (list each item separately)*	\$ _____ \$ _____	
	Subtotal	\$ _____	2
	TOTAL of 1 + 2	\$ _____	A
3.	Labor (itemized breakdown)	\$ _____	3
4.	Insurance (Worker's Compensation, Social Security, or as otherwise required or specified): % [Capped at <u>30%</u>]	\$ _____	4
	TOTAL (A) + 3 + 4	\$ _____	B
5.	Overhead and Profit { <u>15%</u> of Total (B)}**	\$ _____	5
	TOTAL (B) + 5	\$ _____	C
6.	Sales Taxes on Total (A)	\$ _____	6
	TOTAL of (C) +6	\$ _____	D
7.	Subcontracted Work (if applicable in a similar breakdown (through total (D)). Profit and overhead allowance is 15%)	\$ _____	7
8.	Prime Contractor's overhead and profit on item 7 sub-		

contractors' bids (5%)***	\$ _____	8
TOTAL of 7 + 8	\$ _____	E
TOTAL of (D) + (E)	\$ _____	F
9. Performance/Payment Bonds on total (F)	\$ _____	9

Extension of time requested: _____ calendar days
 (Time extension request must be provided with detailed schedule information noting the activities on the critical path that are affected by the change)

Notes:

- *- Include current schedules with each request if equipment is involved.
- **- In case of deductible changes, this figure will be ten percent (10%).
- ***- In case of deductible changes, this figure will be zero percent (0%).

The contractor may submit for approval recent audited financial statements performed in accordance with generally accepted accounting procedures to help establish an overhead rate for this project. Absent of this information, the rates noted above shall apply.

Where the extra Work involved is covered by unit prices quoted in the proposal, or subsequently agreed to by the Contractor, Designer, and the City, the value of the change shall be computed by application of unit prices based on quantities, estimate or actual as agreed of the items involved, except in such cases where a quantity exceeds the estimated quantity allowance in the contract by more than 15%. In such cases, either party may elect to negotiate a new unit price, based on actual costs, or apply the unit prices in the original bid/proposal subject to the Variations in Estimated Quantity requirement.

30. TIME FOR COMPLETION, LIQUIDATED DAMAGES AND TIME EXTENSIONS

The time of completion is expressed as the number of calendar days from the Notice to Proceed. It is hereby understood and mutually agreed, by and between the Contractor and the City, that the date of beginning, rate of progress and the time for completion of the Work are essential conditions of this Contract; and it is further mutually understood and agreed that the Work embraced in this Contract shall be commenced on a date to be specified in the Notice to Proceed.

The Contractor agrees that said Work shall be prosecuted regularly, diligently and uninterrupted at such rate of progress as will insure full completion thereof within the time specified. It is expressly understood and agreed, by and between the Contractor and the City, that the time for the completion of the Work described herein is a reasonable time for the completion of the same, taking into consideration the average climate range prevailing in this locality.

The Contractor shall commence work as outlined in the Notice to Proceed and shall fully complete all work hereunder within the time of completion stated. For each day in excess of the contract completion number of days, the Contractor(s) shall pay the Owner the sum stated as liquidated damages reasonably estimated in advance to cover the losses to be incurred by the Owner by reason of failure of said Contractor(s) to complete the work within the time specified, such time being in the essence of this contract and a material consideration thereof.

The Contractor acknowledges that delays will damage the Owner, but also acknowledges that proof of such damages would be difficult and costly for both parties to determine, and that the injury to the Owner which could result from a failure of the Contractor to complete the Project on schedule is uncertain and cannot be computed with exact precision. In order to liquidate in advance the delay damages that the Owner will be entitled to recover from the Contractor in the event of unexcused delays in the completion of the Project, the Contractor agrees that it will pay, and that the Owner may retain from the funds otherwise

to be paid to the Contractor, the following Liquidated Damages and additional Owner Engineering Expenses and Other Fees, which sums are agreed upon as a reasonable and proper measure of damages which the Owner will sustain by failure of the Contractor to complete Work within the time stipulated, and as Owner's sole and exclusive remedy for any such delays

Owner's Liquidated Damages:

\$250/Day

It is further agreed that time is of the essence for this Contract and of the Specifications wherein a definite portion and certain length of time is fixed for the performance of any act whatsoever; and where under the Contract an additional time is allowed for the completion of any Work, the new time limit fixed by such extension shall be of the essence for this Contract.

Provided, that the Contractor shall not be charged with liquidated damages or any excess cost when the delay in completion of the Work is due to unforeseeable causes beyond the control and without the fault or negligence of the Contractor or that of their subcontractor at any tier, including but not restricted to unavoidable casualties; by acts of God or of the public enemy; by acts of the Government in either its sovereign or contractual capacity; by acts of another Contractor in the performance of a contract with the City; by fires; by floods; by epidemics; by quarantine restrictions; by strikes; by freight embargoes; by unusually severe weather exceeding the average climatic conditions in that area of the Work or by any other causes which the Designer and Owner determine may just the delay, then the contract time may be extended by change order for the time as determined to be reasonable.

Time extensions under this provision do not entitle the Contractor to compensable damages for delays. Any Contractor claim for compensable damages is limited to delays caused solely by the Owner or its agents. Contractor caused delays shall be accounted for before Owner or Designer caused delays in the case of concurrent delays.

Provided further, that the Contractor shall within ten (10) days from the beginning of such delay, notify the City, in writing, of the causes of the delay, who shall ascertain the facts and extent of the delay and notify the Contractor within a reasonable time of its decision in the matter.

31. WEATHER DELAY TIME EXTENSIONS

As noted in the General Conditions Clause entitled, TIME FOR COMPLETION, LIQUIDATED DAMAGES AND TIME EXTENSIONS, if the contract is delayed at any time in the progress of his Work by abnormal weather conditions not reasonably anticipated for the locality where the Work is performed, then the contract time may be extended by change order only for the time which the Designer and Owner may determine is reasonable. The methods to be used for determining the weather delay time extensions are as outlined in this section.

Time extensions will not be granted for rain, wind, snow, or other natural phenomena of normal intensity for the locality where Work is performed. The time for completion includes an allowance for bad weather days based on climatological data and is adjusted to reflect the number of working days per month, which would be affected.

For the purposes of determining the extent of a delay attributable to unusual weather phenomena, please see the table below which notes the maximum number of days by month that can be considered "bad weather" days. For the purposes of this contract, bad weather days to be anticipated are defined as follows:

- a. Days on which precipitation exceeds 0.10 inch.
 - b. Days on which the temperature fails to exceed 40 degrees F average.
- (A day, which qualifies on criteria for both precipitation and temperature, shall be counted as one day.)

Bad weather working days to be included in the contractor's schedule are:

Month	Days	Month	Days	Month	Days
January	17	May	7	September	5
February	15	June	4	October	3
March	5	July	5	November	9
April	4	August	5	December	10

The Contractor shall note actual job site weather conditions on the daily report of construction, along with work performed and any effect of weather conditions on the scheduled activities. Tabulations of weather conditions on the job site, and any effects of weather on the critical path activities, shall be totaled on a monthly basis as work progresses. Periods where weather conditions are more favorable than anticipated shall also be accounted in the weather analysis. If the total accumulated number of working days lost to bad weather exceeds the total number tabulated above, the time for completion will be extended by the difference. Time of completion will not be adjusted for actual bad weather days which total less than the number included in the tabulation.

No weather delays shall be considered for building or structure construction after the building or structure has been dried in, unless such other Work claimed to be delayed is on the critical path of the baseline schedule or approved updated schedule. This determination will be made in consultation between the Designer and Owner.

32. PAYMENTS TO CONTRACTOR

Cost Breakdown – The Contractor shall be prepared to submit a cost breakdown / schedule of values immediately after the opening of Bids. Cost breakdown shall be based on values of parts of the Work as divided according to sections of the Specifications and shall be further subdivided into labor and materials. The Contractor shall use forms similar to the AIA G702 & G703 Forms for cost breakdown and payment requests. Other pay request forms as provided or approved by the Owner may also be used.

Applications for payment shall be submitted to the Designer for review and certification prior to submittal to the Owner for payment. Applications that have not been certified by the Designer shall be rejected by the Owner and returned to the Contractor. Designers will forward certified pay applications to the Project Manager for prompt payment. The pay application shall include the following information:

1. Total of the contract including change orders or approved authorization requests.
2. Value of Work completed to date.
3. Less 5% Retainage (see additional clarification in this section).
4. Less previous payments.
5. Current amount due.
6. The Contractor shall provide a sales tax statement certifying the amount of sales taxes paid for the Work provided under the contract. Manufacturers are not exempt from paying North Carolina sales taxes for providing an item directly to the City of Raleigh. If you have any questions about the sales tax requirements for the state of North Carolina, please contact the North Carolina Department of Revenue at (919)707-0880.
7. Updated progress schedule reflecting scheduled and actual completion percentages for the overall project as well as activity progress.

As specified in G.S. 143-134.1(b), within seven (7) days of receipt of payment by the Contractor of each periodic or final payment, the Contractor shall pay its subcontractor(s) based on Work completed or service(s) provided. If any periodic or final payment to the subcontractor is delayed by more than seven days after receipt of periodic or final payment by the Contractor, the Contractor shall pay the subcontractor interest, beginning on the eighth day, as a rate of one percent (1%) per month or fraction thereof on the unpaid balance as is due.

In accordance with G.S. 143-134.1(b1), no retainage on periodic or final payments made by the Owner or Contractor shall be allowed on public construction contracts in which the total project costs are

less than one hundred thousand dollars (\$100,000). When the project is fifty percent (50%) complete, the Owner, with written consent of the surety, shall not retain any further retainage from periodic payments due the Contractor, if the Contractor continues to perform satisfactorily and any nonconforming Work identified in writing prior to that time by the designer or Owner has been corrected and accepted by the designer or Owner. If the Owner determines that the Contractor's performance is unsatisfactory, the Owner may reinstate retainage.

Each pay application shall reference the Owner's assigned purchase order number.

Materials and Work Covered by Partial Payments - All materials and Work covered by progress payments shall, upon payment thereof, become the sole property of the Owner, but this provision shall not be construed as relieving the Contractor from the sole responsibility for the care and protection of materials and Work upon which payments have been made, or the restoration of any damaged Work.

33. STORED MATERIALS

In the preparation of partial estimates, the Owner **may** authorize payment for material delivered to the site and preparatory work done to be taken into consideration subject to the following requirements:

- 1) The materials have been submitted and approved for use on the project.
- 2) The materials are satisfactorily stored to protect the materials for their intended use.
- 3) The Contractor has provided a detailed paid bill of sale or invoice that notes the type and quantity of material included on the invoice, complete with a schedule of unit price values, such that the material inventory can be tracked during installation.

The Contractor shall provide inventory control schedule with each partial payment request that reflects that type of stored material, quantity, unit prices, a schedule noting opening, used that period and ending inventory of materials and total summary of stored material amount being requested on the partial estimate. A copy of a suitable form that may be used by the Contractor is included as an attachment.

The Contractor acknowledges that it has responsibility to insure and protect such stored materials under the terms of its bond and insurance coverage with the Owner, and to maintain such stored materials in proper condition for installation and to fulfill the contract requirements when installed. Payment for the materials as described shall constitute a transfer of title to the Owner but such transfer does not relieve the Contractor of the responsibility to inspect, safeguard and protect the stored materials until they are incorporated into the permanent work. Payment for the materials does not constitute the start of any warranty, either express or implied, as such action shall not begin until the installation is complete and the work accepted.

The Contractor shall be responsible for the safety and security of subject materials and assume all risk for loss of materials.

Materials delivered to the Contractor at locations other than the project site may also be taken into consideration if, in addition to the above, the Contractor provide evidence the materials are being stored in a secured and protected facility and environment. The location for such storage shall be approved by the Designer / Owner.

34. PAYMENTS WITHHELD

The Designer may recommend to the Owner to withhold payment for any of the following reasons:

- a. Faulty Work not corrected.
- b. The unpaid balance on the contract is insufficient to complete the Work in the judgment of the Designer.
- c. To provide for sufficient contract balance to cover liquidated damages that will be assessed.

d. Evidence that subcontractors have not been paid.

35. SCHEDULES, REPORTS AND RECORDS

The Contractor shall submit to the city such schedule of quantities and costs, progress schedules, payrolls, reports, estimates, records, and other data as the Designer may request concerning Work performed or to be performed.

The Contractor shall submit to the city within thirty (30) days after the issuance of the Notice to Proceed schedules showing the order in which he proposes to carry on the Work, including dates at which he will start the various parts of the Work, estimated date of completion of each part; and, as applicable, the dates at which special detail drawings will be required, and respective dates for submission of Shop Drawings, the beginning of manufacture, the testing and the installation of materials, supplies and equipment. The basic project schedule shall be presented at the preconstruction meeting and no partial payments shall be made until it has been submitted to the City.

The Contractor shall submit updated schedules at each monthly meeting or at the request of the Owner. If any activities are behind schedule, the Contractor must indicate in writing what measures will be taken to bring each activity back on schedule and to ensure that the contract completion date is not exceeded. A plan of action and recovery schedule shall be developed and submitted to the Owner when: (1) the Contractor's report indicates delays, that are in the opinion of the Owner, of sufficient magnitude that the Contractor's ability to complete the Work by the scheduled completion date is brought into question; or (2) the updated construction schedule is thirty (30) days behind the planned or baseline schedule and no legitimate time extensions are in process or have been approved; or (3) the Contractor desires to make changes in the logic (sequencing of Work) or the planned duration of future activities of the CPM schedule which, in the opinion of the Owner, are of a major nature. The plan of action, when requested by the Owner, shall be submitted to the Owner, within five calendar (5) days of the request. The recovery schedule, when required, shall be submitted to the Designer and Owner, within five (5) calendar days of the request.

Failure to provide updated construction schedules, plans of action, or recovery schedules, as requested or required, shall be considered grounds for rejection of pay applications.

36. CITY'S RIGHT TO TERMINATE

See the City of Raleigh Form of Contract concerning the City's right to terminate.

37. FINAL ACCEPTANCE OF WORK AND FINAL PAYMENT

Before issuing final payment, the Contractor shall promptly remove from the premises all materials condemned by the Owner's Representative or Consultant as failing to conform with the Contract, whether incorporated in the work or not, and the Contractor shall promptly replace and re-execute his own work in accordance with the Contract and without expense to the City and shall bear the expense of making good all work of other contractors destroyed or damaged by such removal or replacement.

Final Acceptance shall occur when the Designer and Owner mutually agree to accept the project from the contractor. Final acceptance of the project shall not be considered before the final inspection is conducted. Final acceptance of the project may occur prior to correction of punch list items.

Final Inspection: Upon notice from the Contractor that his Work is completed, the Designer and Owner shall make a final inspection of the Work and shall notify the Contractor of all instances where his Work fails to comply with the Drawings and Specifications, as well as any defects he may discover. Deficiencies shall be recorded on a "punch list" and the Contractor shall immediately make such alterations as are necessary to make the Work comply with the Drawings and Specifications.

Final Payment: When the Work under this Contract is completed, a final payment request shall be submitted representing the original Contract Price, cost events, and change orders to the Contract. The

final payment shall not be due until the Contractor shall have completed all Work necessary and reasonably incidental to the Contract, including final clean up.

The final payment of monies or retained amount due the Contractor for the contract shall not become due until the Contractor has furnished to the Owner, through the Designer, an affidavit signed, sworn and notarized to the effect that all payments for materials, services or subcontracted work in connection with his contract have been satisfied, and that no claims or liens exist against the Contractor in connection with this contract. To the event that the Contractor cannot obtain similar affidavits from sub-contractors to protect the Contractor and the Owner from possible liens or claims against the sub-contractor, the Contractor shall state in his affidavit that no claims or liens exist against any sub-contractor to the best of his (the Contractor's) knowledge, and, if any appear afterward, the Contractor shall hold and save the Owner harmless.

The final payment may not be processed until the Designer has certified that the project has been completed in accordance with the contract Specifications and drawings.

Final acceptance of the Work and the making of final payment shall not constitute a waiver of any claims by the City. Payments otherwise due the Contractor, including Retainage, may be withheld by the City because of defective Work not remedied and unadjusted damage to others by the Contractor or Subcontractors, vendors or laborers.

All requests for final payment must be submitted within 60 days after the Work has been completed and accepted by the City. All requests are subject to final approval and audit by the City of Raleigh.

38. CONSTRUCTION INSPECTION

The Contractor shall maintain an adequate inspection system and perform all inspections to ensure that the work performed under this contract, including that of all subcontractors, is performed per the contract requirements. The Contractor shall maintain complete inspection records and shall make them available to the City. All work shall be conducted under the general direction of the Contractor. As referenced in Section 13, Inspection of Work by Other Parties, all work is subject to City inspection and tests at all places and at all reasonable times before final acceptance to ensure compliance with the terms of this contract. Such inspections by the City are for the benefit of the City and do not relieve the Contractor of its responsibility for providing adequate inspection and control measures for its work and the work of its subcontractors. Such inspections do not constitute any acceptance of the work by the City unless such partial acceptance is done in writing by the City and clearly indicates the scope of work that is being accepted by the City.

As stated in Section 16. Rejection of Work and Materials and Owner's Right to Do Work, the Contractor shall promptly replace or correct work, without charge, that is found to be in non-conformance with contract requirements unless, in the City's interest, the City consents to accept the work with an appropriate adjustment in the contractor price.

The Contractor shall promptly segregate and remove any rejected work or materials from the work area. If the contractor does not promptly remove or correct defective or rejected work, the City may replace or correct the work and charge the cost to the Contractor or terminate the contract for Default.

39. QUALITY CONTROL

The contractor shall develop and implement a quality control system on subject project to ensure the construction is performed per contract requirements. The quality control system shall consist of plans, procedures, and organization necessary to produce an end-product, which complies with the contract requirements. The system shall cover all construction operations, both onsite and offsite, and shall be keyed to the proposed construction sequence. The system shall also include all work performed by its subcontractors. The Contractor's project superintendent, separate quality control manager or other designated individual will be appointed by the Contractor to be responsible for the quality of work on the job site. The designated individual shall have the authority to require corrective action for work found to not

be in compliance with the contract requirements. Deficiencies and non-conforming work shall be tracked until they have been corrected and found to be in compliance with requirements. Results of quality control inspections shall be documented on the daily report of construction.

40. GUARANTEE AND CORRECTION OF WORK

The Contractor shall guarantee all Work to have been accomplished in conformance with the Contract Documents. Neither the final payment application nor any provision of the Contract Documents, nor partial or entire occupancy or use of the Work by the City, shall constitute an acceptance of any part of the Work not done in accordance with the Contract Documents, or relieve the Contractor of liability for incomplete or faulty materials or workmanship. The Contractor shall promptly remedy any omission or defect in the Work and pay for any damage to other improvements or facilities resulting from such omission or defect which shall appear within a period as defined in the Supplemental Conditions. In the event that the Contractor should fail to make repairs, adjustments or other remedy that may be made necessary by such defects, the City may do so and charge the Contractor the cost thereby incurred.

41. DIFFERING SITE CONDITIONS

Should the Contractor encounter subsurface or latent conditions, or both, at the site, materially differing from those shown on the drawings or indicated in the specifications or differing materially from those ordinarily encountered and generally recognized as inherent in Work of the character provided for in this Agreement, the Contractor shall immediately, and in no event later than ten (10) days later, give notice to the Designer / Owner of such conditions before they are disturbed. The Designer and Owner shall thereupon promptly investigate the conditions and if they find that they materially differ from those shown on the drawings or indicated in the specifications, they shall at once make such changes in the drawings and/or specifications as they may find necessary. Any increase or decrease in the Cost of the Work resulting from such changes shall be adjusted in the manner provided herein for adjustments as to extra and/or additional Work and changes. However, neither the Owner nor the Designer shall be liable or responsible for additional Work, costs or changes to the Work that should have been reasonably determined from any geotechnical, soils and other reports, surveys and analyses made available for the Contractor's review or that should have been reasonably discovered by the Contractor through site observations or through the performance of its obligations pursuant to this Agreement.

42. WARRANTY OF CONSTRUCTION

The Contractor shall unconditionally warrant materials and workmanship against defects arising from faulty materials, faulty workmanship or negligence for a period of twelve (12) months following the date of final acceptance of the work or date of beneficial occupancy and shall replace such defective materials or workmanship without cost to the Owner.

If the Owner takes possession of any part of the work before final acceptance, this warranty shall continue for a period of 1 year from the date the Owner takes possession.

The Contractor shall remedy at the Contractor's expense any failure to conform, or any defect. In addition, the Contractor shall remedy at the Contractor's expense any damage to owned or controlled real or personal property, when that damage is the result of--

- (1) The Contractor's failure to conform to contract requirements; or
- (2) Any defect of equipment, material, workmanship, or design furnished.

The Contractor shall restore any work damaged in fulfilling the terms and conditions of this clause. The Contractor's warranty with respect to work repaired or replaced will run for 1 year from the date of repair or replacement.

The Owner shall notify the Contractor, in writing, within a reasonable time after the discovery of any failure, defect, or damage. If the Contractor fails to remedy any failure, defect, or damage within a reasonable

time after receipt of notice, the Owner shall have the right to replace, repair, or otherwise remedy the failure, defect, or damage at the Contractor's expense.

With respect to all warranties, express or implied, from subcontractors, manufacturers, or suppliers for work performed and materials furnished under this contract, the Contractor shall--

- (1) Obtain all warranties that would be given in normal commercial practice;
- (2) Require all warranties to be executed, in writing, for the benefit of the Owner,
- (3) Enforce all warranties for the benefit of the Owner, if directed by the Owner.

Where items of equipment or material carry a manufacturer's warranty, or an extended warranty required by the specifications, for any period in excess of twelve (12) months, then the manufacturer's warranty or extended warranty shall apply for that piece of equipment or material. The Contractor shall replace such defective equipment or materials, without cost to the Owner, within the manufacturer's warranty period.

Additionally, the Owner may bring an action for latent defects caused by the negligence of the Contractor for defects which are hidden or not readily apparent to the Owner at the time of beneficial occupancy or final acceptance, whichever occurred first, in accordance with applicable law.

43. CONTRACTOR EVALUATION

The Contractors overall Work performance on this project shall be fairly evaluated by the Owner and the Designer for determining qualifications to bid on future City projects. In addition to the final evaluation, interim evaluations may be prepared during the progress of the project. The Owner may also request the Contractor's comments to evaluate the Designer's performance.

CITY OF RALEIGH COST CHANGE PROPOSAL
 Authorizing use of Owner's Contingency Allowance with Construction Contract

Contractor Name & Address: Date:

Project Name & ID: CCP No.
Note: If CCP is a credit to the Owner's Contingency Allowance, please enter amounts as negative.

Description of Change:

1	Products	(Itemized breakdown attached)	<input type="text"/>	
2	Rental of Equipment		<input type="text"/>	
		Subtotal of line 1 + line 2=	\$ -	ITEM A
3	Labor	(Itemized breakdown attached)	<input type="text"/>	
4	Insurance	(Worker's Comp, SS, etc.) <input type="text"/> % of line 3, 30% max	\$ -	
		Subtotal: (ITEM A)+line 3+line 4=	\$ -	ITEM B
5	Overhead & Profit		\$ -	
		15% of ITEM if add or 20% of ITEM B if deduct <input type="text"/>	0.00	
		Subtotal: (ITEM B)+line 5	\$ -	ITEM C
6	Sales Tax on ITEM A		<input type="text"/>	
		Subtotal: (ITEM C)+line 6	\$ -	ITEM D
7	Subcontracted Work (if applicable, with itemized breakdown)		<input type="text"/>	
8	Prime Contractor's Overhead & Profit (5% of line 7)		\$ -	
		5% if this is an add; 0% if this is a deduct <input type="text"/>	\$ -	
		Subtotal: line 7+line 8	\$ -	ITEM E
		Subtotal: ITEM D+ITEM E	\$ -	ITEM F
9	Performance/Payment Bonds	<input type="text"/> % of ITEM F	\$ -	
		TOTAL COST CHANGE PROPOSAL (CCP): ITEM F+line 9	\$ -	ITEM G
		Extension of Time Requested: <input type="text"/> days		

Proposal by: (Contractor)

Accepted by: (Designer/Engineer of Record)

Authorization for Debit/Credit to be applied to Owner's Contingency Allowance

10	Original Amount of Owner's Contingency Allowance	<input type="text"/>
11	Total CCPs previously approved (enter credits as negative)	<input type="text"/>
12	Current CCP Authorization Request	\$ -
13	Owner's Contingency Allowance Remaining	\$ -

TOTAL CCPs approved to date \$ - Use this amount for line 11 on next CCP

By signature below, the City of Raleigh authorizes the use of the Owner's Contingency Allowance funds and authorizes the above CCP to proceed in accordance with the construction contract. Any accepted time extension will be processed as a change order.

For the City of Raleigh: _____

SUPPLEMENTARY GENERAL CONDITIONS

INDEX TO SUPPLEMENTARY GENERAL CONDITIONS

<u>SECTION</u>	<u>TITLE</u>	<u>PAGE</u>
01	Emergency Contacts	SGC-2
02	Operations of Owner's Facilities	SGC-2
03	Disadvantaged Business Enterprise Participation	SGC-2
04	Accident Prevention	SGC-2
05	Preconstruction Photos / Video	SGC-2
06	Progress Photos	SGC-3
07	Sanitary Facilities	SGC-3
08	Contractor License / Privilege License	SGC-3
09	Material Tickets	SGC-3
10	Final Cleaning	SGC-3
11	Sales Tax	SGC-3

1. EMERGENCY CONTACTS

The Contractor shall provide by letter names, telephone numbers and addresses of two responsible company representatives prior to beginning work. These two representatives are to be capable and authorized to respond to emergencies, so which arise during the project, nights, holidays or week-ends. The Contractor, by submitting these person's names, certifies that at least one representative will be available for on call emergency response at all times.

2. OPERATIONS OF OWNER'S FACILITIES

The Contractor agrees that all Work done under the Contract Documents shall be carried on in such a manner so as to ensure the regular and continuous operation of the adjoining or adjacent facilities. The Contractor further agrees that the sequence of operations under the Contract Documents shall be scheduled and carried out so as to ensure said regular and continuous operation. The Contractor shall not close any areas of construction until so authorized by the Owner. The Contractor shall control his operations and those of his Subcontractors and all suppliers, to assure the least inconvenience to the public. Under all circumstances, safety shall be the most important consideration.

- (b) The Owner will occupy the site and existing building during construction except as herein noted. Cooperate with the Owner to minimize conflicts and facilitate owner usage. Perform the work so as not to interfere with the Owner's operations.
- (c) The Owner reserves the right to occupy and place and install equipment in selected construction areas prior to Substantial Completion without accepting the Work in total.

3. DISPOSAL OF WASTE MATERIALS FROM ANY CONSTRUCTION.

Disposal of all waste material from construction sites shall be made in strict accordance with all State laws and City ordinances pertaining to disposal of construction or hazardous waste. It shall be the responsibility of the Contractor to secure the necessary permits and provide all information required to secure said permits. The Contractor shall designate the disposal site prior to beginning construction and in the event waste material is to be disposed of on private property a letter from the property owner shall be furnished the Owner's Representative granting the Contractor or his agent such permission and listing the requirements made by the property owner on the Contractor, if any.

4. ACCIDENT PREVENTION

To supplement the provisions as outlined in the Contract, the Contractor shall provide all necessary safety measures for the protection of all persons on the project, including the requirements outlined in the Contract, the A.G.C. *Accident Prevention Manual in Construction*, as amended, and shall fully comply with all state laws or regulations, the North Carolina State Building Code and other requirements to prevent accident or injury to persons on or about the location of the work. The Contractor shall clearly mark or post signs warning of hazards existing, and shall barricade excavations, elevator shafts, stairwells and similar hazards. The Contractor shall protect against damage or injury resulting from falling materials and he shall maintain all protective devices and signs throughout the progress of the work.

The Contractor shall adhere to the rules, regulations and interpretations of the Department of Labor relating to Occupational Safety and Health Standards for the Construction Industry (Title 29, Code of Federal Regulations, Part 1926, *Federal Register*), and revisions thereto.

The Contractor shall designate a responsible member of his organization as safety inspector, whose duties shall include accident prevention on the work project. The name of the safety inspector shall be made known to the Designer and Owner's Representative at the time the work is started.

5. PRECONSTRUCTION PHOTOS/VIDEO

The Contractor shall document pre-existing conditions on the project site and submit the photos / video in electronic

format. The intent of these photos / video is to document the project conditions such as the pavement and driveways; the condition of the curb & gutter; the condition of the adjoining site boundary; installed improvements and drainage; the condition of the grassing; the condition of any structures and other improvements prior to the start of construction.

The Contractor may also include any pre-existing conditions it wants brought to the attention of the Designer and Owner by including notes and time position on the index sheet. The documentation must be submitted before mobilization to the site.

6. PROGRESS PHOTOS

The Contractor shall document construction on the project with weekly photographs. Photographs shall be digital with resolution equivalent to a 3-inch by 5-inch color photograph. Photos shall be submitted to the Owner digitally. Any information the Contractor wishes to describe regarding the progress photos shall be accompanied with a detailed description and date. Progress photos shall be provided for each payment request submitted by the Contractor. Progress photos may also be provided with daily reports.

7. SANITARY FACILITIES

The Contractor shall furnish, install, and maintain ample sanitary facilities for the workers. As the needs arise, a sufficient number of enclosed temporary toilets shall be conveniently placed as required by the sanitary codes of the State and City of Raleigh. Drinking water shall be provided from an approved source, so piped or transported as to keep it safe and fresh and served from single service containers or satisfactory types of sanitary drinking stands or fountains. All such facilities and services shall be furnished in strict accordance with existing and governing health regulations. No separate payment will be made for providing these

8. CONTRACTOR LICENSE/PRIVILEGE LICENSE

All invited bidders and contractors shall be advised that those who submit formal bids on this project must be licensed in the State of North Carolina, in accordance with GS 87-10, and shall be advised that they must show evidence of a current license issued by the North Carolina Licensing Board for General Contractors.

The contractor shall provide evidence of current privilege license.

9. MATERIAL TICKETS

For all work to be paid based on the basis of a material quantity, the Contractor shall turn in all material tickets from the source of supply for the purpose of payment to the Owner on a daily basis. Such tickets shall be totaled by the Contractor and included on the Contractor's daily report of construction.

10. FINAL CLEANING

Final cleaning of the premises shall be left broom clean. Stains, foreign substances, and temporary labels shall be removed from surfaces. Paved areas shall be swept and landscaped areas shall be raked clean. The site shall have waste, surplus materials, and rubbish removed. The project area shall have temporary structures, barricades, project signs, and construction facilities removed. A list of any uncompleted clean-up items shall be submitted on the day of final inspection.

11. SALES TAX

North Carolina Sales Tax and Use Tax and Local Option Sales and Use Tax do apply to materials entering into Municipal Work (N.C. Sales and Use Tax Regulations No. 42 & 57, Paragraph A), and such costs shall be included in the bid proposal and contract sum.

The procedures for reporting sales taxes paid by the contractor are as follows:

1.
 - (a) It shall be the general contractor's responsibility to furnish the owner documentary evidence showing the materials used and sales tax paid by the general contractor and each of his sub-contractors and where paid. Any county sales tax included in the contractor's statements must be shown separately from the state sales tax. If more than one county is shown, each county shall be listed separately.
 - (b) The documentary evidence shall consist of a certified statement, by the general contractor and each of his subcontractors individually, showing total purchases of materials from each separate vendor and total sales taxes by each county paid each vendor. The certified statement must show the invoice number (s) covered and inclusive dates of such invoices. State sales tax shall be listed separately from county sales tax. If more than one county is shown, each county shall be listed separately.
 - (c) Materials used from general contractor's or sub-contractor's warehouse stock shall be shown in a certified statement at warehouse stock prices.
 - (d) The general contractor shall not be required to certify the sub-contractor's statements.
 - (e) The documentary evidence to be furnished to owners eligible for sales or use tax refunds covers sales and or use taxes paid on building materials used by contractors and sub-contractors in the performance of contract with churches, orphanages, hospitals not operated for profit and other charitable or religious institutions or organizations not operated for profit and, incorporated cities, towns, and counties in this State. The documentary evidence is to be submitted to the above-named institutions, organizations and governmental units to be included in claims for refunds to be prepared and submitted by them to obtain refunds provided by G. S. 105-164.14 (2) and (3) of the 1961 Statute and is to include the purchases of building materials, supplies, fixtures and equipment which become a part of or annex to buildings, or structures being erected, altered or repaired under contract with such institutions, organizations, or governmental units.
2. The contractor is advised that all requests for payment, partial or final, for work completed under this contract must include a sales tax report submitted in accordance with the procedures outlined above.

**PROCEDURE FOR REPORTING NORTH CAROLINA SALES TAX
EXPENDITURES ON CITY OF RALEIGH CONTRACTS**
(for projects with reimbursable sales tax excluded from Bid)

1. The following procedure in handling the North Carolina Sales Tax is applicable to this project. Contractors shall comply fully with the requirements outlined hereinafter, in order that the owner may recover the amount of the tax permitted under the law. For the purposes of this section, "Sales Taxes" shall mean sales and use taxes paid to the State of North Carolina or to local governments in North Carolina.
 - (a) Reimbursable Sales Taxes are to be excluded from the bid price for this project.
 - (b) The City is entitled to refunds from the State of North Carolina for these reimbursable sales taxes. The Contractor that performs work under this contract is allowed to obtain a reimbursement from the City for those Sales Taxes for which the State will grant a refund to the City. The City will reimburse the Contractor, and the City later obtains a refund from the State.
 - (c) It shall be the general contractor's responsibility to furnish the City documentary evidence showing the materials used and sales tax paid by the general contractor and each of his subcontractors. Any county sales tax included in the contractor's statements must be shown separately from the state sales tax. If more than one county is shown, each county shall be listed separately.
 - (d) The documentary evidence shall be the attached Reimbursable Sales and Use Tax Statement. This evidence shall consist of a certified statement, by the general contractor and each of his subcontractors individually, showing total purchases of materials from each separate vendor and total sales taxes by each county paid each vendor. The certified statement must show the invoice number (s) covered and inclusive dates of such invoices. State sales tax shall be listed separately from county sales tax. If more than one county is shown, each county shall be listed separately. The invoices shall be provided to substantiate the information on the statement.
 - (e) Materials used from general contractor's or subcontractor's warehouse stock shall be shown in a certified statement at warehouse stock prices.
 - (f) The general contractor shall not be required to certify the subcontractor's statements. However, the subcontractor may submit for reimbursement by certifying a Reimbursable Sales and Use Tax Statement, submitting it to the general contractor for the general contractor to submit with the pay application for the properties listed on that form. The City will make the reimbursement payable to the Contractor.
 - (g) The documentary evidence to be furnished to owners eligible for Reimbursable Sales Tax refunds covers sales and/or use taxes paid on building materials used by general contractors and subcontractors in the performance of contracts with churches, orphanages,

hospitals not for profit, educational institutions not operated for profit and other charitable or religious institutions or organizations not operated for profit and incorporated cities, towns and counties in this State. The documentary evidence is to be submitted to the above-named institutions, organizations and governmental units to be included in claims for refunds to be prepared and submitted by them to obtain refunds provided by G.S. 105-164.14 and is to include the purchase of building materials, supplies, fixtures and equipment which become a part of or annexed to buildings or structures being erected, altered or repaired under contracts with such institutions, organizations or governmental units.

- (h) The Contractor may seek reimbursement separately from, but at the same time as, the application for payment is made for the properties that were taxed. The Contractor shall not file for reimbursement for Sales Taxes before the Contractor has the right to file an application for payment for the properties that were taxed.
- 2. If the State refuses to refund any such Sales Tax to the City, or if after a refund is made, the City is told to return a refund to the State, the Contractor shall upon demand repay the City for the amount of the failed refunds.
- 3. The contractor or contractors to whom an award is made on this project will be required to follow the procedure outlined above.
- 4. The contractor is advised that all requests for payment, partial or final, for work completed under this contract must include a sales tax report submitted in accordance with the procedures outlined above.

