

CITY OF RALEIGH
Bridge Repair and Preservation
PROJECT NO. 274-TM-3-26R

DATE OF ADVERTISING: June 8th, 2026

DATE OF PRE-BID CONFERENCE: N/A

DATE QUESTIONS DUE: June 15th, 2026, 5:00 p.m.

DATE FOR RESPONSES BY THE CITY: June 17th, 2026, 5:00 p.m.

DATE OF BID OPENING: June 22nd, 2026, 2:00p.m.

NAME OF BIDDER:

ADDRESS:

NC LICENSE NO.:

BID DEPOSIT 5%:

TOTAL BID:

MWBE PERCENTAGE:

CONTRACTOR SIGNATURE:

TABLE OF CONTENTS

ADVERTISEMENT	3
BID	4 - 5
BID BOND	6 - 7
INSTRUCTIONS TO CONTRACTORS	8
CONTRACT	9 - 23
NON DISCRIMINATION AGREEMENT	24
MINORITY DOCUMENTATION FORMS	25 - 45
PERFORMANCE BOND	46 - 49
PAYMENT BOND	50 - 53
PROCEDURE FOR REPORTING SALES TAX	54 - 57
FINAL PAYMENT AFFIDAVIT	58
SCHEDULE OF PRICES	59-60
GENERAL CONDITIONS	61 - 83
STANDARD GENERAL PROVISIONS	84 - 87
PROJECT SPECIFICATIONS	88 - 143
APPENDIX	144 - 148

ADVERTISEMENT

CITY OF RALEIGH PROJECT NO. 274-TM-3-26R

Bridge Repair and Preservation

Pursuant to the General Statutes of North Carolina, Section 143-128 et. seq, sealed proposals are invited and will be received by the City of Raleigh at the Transportation Field Services Office until 2:00 p.m. on June 22nd, 2026 at which time a meeting at 2550 Operations Way, Raleigh, N.C., the sealed proposals will be publicly opened for construction consisting of furnishing and installing the following:

- This project is for the repair and preservation of the various bridges within the City of Raleigh.

Copies of the contract proposal may be obtained from the City of Raleigh beginning June 8th, 2026 for no fee, provided conditions are met as outlined in the bid documents.

A Mandatory Pre-Bid Conference will not be held. In review of the bid, Vendors may have questions to clarify or interpret the bid to submit the best bid possible. To accommodate the bid questions, Vendors shall submit any such questions by 5:00 p.m. on June 15th, 2026. The City will not entertain any further questions after the deadline. Send your questions via email to Daniel.Callahan@raleighnc.gov with the bid number in the subject line of your email. The City will answer all questions in addenda to the bid and post on the IPS website.

No proposal will be considered or accepted unless at the time of its filing, the same shall be accompanied by a cash deposit, cashier's check, or certified check on a bank or trust company insured by the FDIC and authorized to do business in North Carolina in an amount equal to five percent (5%) of the proposal. In the alternative, a five percent (5%) bid bond issued by a corporate surety licensed by the State of North Carolina may be filed with the proposal. Bidders must be properly licensed under Chapter 87 of the General Statutes of North Carolina and must comply with nondiscrimination provisions. The City is an equal opportunity Municipality/Owner and invites small and minority contractors to bid. The City Council reserves the right to reject any or all proposals.

This the 8th day of June, 2026.

THE CITY OF RALEIGH
Janet Cowell, MAYOR
Paul Kallam, DIRECTOR, DEPT OF TRANSPORTATION

BID FORM

PROPOSAL FOR THE CONSTRUCTION OF PROJECT NO. 274-TM-3-26R
IN THE CITY OF RALEIGH, NORTH CAROLINA

DATE

CITY COUNCIL

CITY OF RALEIGH

RALEIGH, NORTH CAROLINA

Ladies and Gentlemen:

The undersigned bidder has carefully examined the Form of Contract, the Form of Contract Bonds, the General Conditions, the Special Conditions, the Plans and Specifications, all of which are acknowledged to be a part of the proposal, and the Proposal Form; and he has also carefully examined the site of the proposed work. The undersigned bidder agrees to bind himself on award to him by the City Council of the City of Raleigh under this proposal, to execute within ten (10) days, in accordance with such award, a Contract with necessary surety bonds, of which Contract this proposal and the plans and specifications shall be a part, to provide all necessary machinery, tools, labor, and other means of construction, and to do all the work and to furnish all materials, except as otherwise noted, necessary to perform and complete the said project within the time limit specified below.

In addition to all other agreements and assurances, the undersigned bidder understands and hereby agrees as follows:

1. If this Contract is awarded, the bidder must, upon completion of this Contract, or at any other time requested, furnish to the City of Raleigh an accurate itemized statement of North Carolina Sales Tax paid on materials, supplies, equipment and any other items charged to this Contract, and otherwise fully comply with the "Procedure for Reporting North Carolina Sales Tax Expenditures", attached.
2. The bidder further agrees to begin work within **10** calendar days from date of Contract Notice to Proceed.
3. The bidder represents and agrees to complete proposed work by November 30th, 2026.

Submitted this _____ day of _____, 2026.

Name of bidder: _____

Address: _____

BIDDER’S CERTIFICATION

Acceptance of Terms

In submitting this Proposal, the undersigned agrees that this bid will remain in effect for a period of 60 days following the opening of the Bids, that the undersigned agrees to enter into a Contract with the Owner, if awarded, on the basis of this Proposal, and that the undersigned agrees to complete the work in accordance with the Contract Documents.

Non-Collusion in Bidding

The Bidder specifically agrees to abide by all applicable provisions of Article 3 of Chapter 133 of the North Carolina General Statutes. By submission of this Bid, each Bidder and each person signing on behalf of any Bidder certifies, and in case of a joint Bid each party thereto certifies as to its own organization, under penalty of perjury, that to the best of knowledge and belief:

1. The prices in this Bid have been arrived at independently without collusion, consultation, communication, or agreement, for the purpose of restricting competition, as to any matter relating to such prices with any other Bidder or with any competitor,
2. Unless otherwise required by Law, the prices quoted in the Bid have not been knowingly disclosed by the Bidder and will not knowingly be disclosed by the Bidder prior to opening, directly or indirectly, to any other Bidder or to any competitor, and
3. No attempt has been made or will be made by the Bidder to induce any other person, partnership, or corporation to submit or not to submit a Bid for the purpose of restricting competition.

Type of Business

The undersigned hereby represents that it is a _____ (corporation, partnership, an individual or limited liability company). If a corporation, the undersigned further represents that it is duly qualified as a corporation under the Laws of the State of North Carolina and it is authorized to do business in this State.

Firm Name

Date

Authorized Signature

Bridge Preservation & Repair

Name of Project

Title

Address of Firm

BID BOND (PENAL SUM FORM)

Bidder Name: Address <i>(principal place of business)</i> :	Surety Name: Address <i>(principal place of business)</i> :
Owner Name: City of Raleigh Address <i>(principal place of business)</i> : 222 W. Hargett Street Raleigh, NC 27601	Bid Project <i>(name and location)</i> : Bid Due Date:
Bond Penal Sum: Date of Bond:	
Surety and Bidder, intending to be legally bound hereby, subject to the terms set forth in this Bid Bond, do each cause this Bid Bond to be duly executed by an authorized officer, agent, or representative.	
Bidder	Surety
<i>(Full formal name of Bidder)</i>	<i>(Full formal name of Surety) (corporate seal)</i>
By: _____ <i>(Signature)</i>	By: _____ <i>(Signature) (Attach Power of Attorney)</i>
Name: _____ <i>(Printed or typed)</i>	Name: _____ <i>(Printed or typed)</i>
Title: _____	Title: _____
Attest: _____ <i>(Signature)</i>	Attest: _____ <i>(Signature)</i>
Name: _____ <i>(Printed or typed)</i>	Name: _____ <i>(Printed or typed)</i>
Title: _____	Title: _____
<i>Notes: (1) Note: Addresses are to be used for giving any required notice. (2) Provide execution by any additional parties, such as joint venturers, if necessary.</i>	

1. Bidder and Surety, jointly and severally, bind themselves, their heirs, executors, administrators, successors, and assigns to pay to Owner upon default of Bidder the penal sum set forth on the face of this Bond. Payment of the penal sum is the extent of Bidder's and Surety's liability. Recovery of such penal sum under the terms of this Bond will be Owner's sole and exclusive remedy upon default of Bidder.
2. Default of Bidder occurs upon the failure of Bidder to deliver within the time required by the Bidding Documents (or any extension thereof agreed to in writing by Owner) the executed Agreement required by the Bidding Documents and any performance and payment bonds required by the Bidding Documents.
3. This obligation will be null and void if:
 - 3.1. Owner accepts Bidder's Bid and Bidder delivers within the time required by the Bidding Documents (or any extension thereof agreed to in writing by Owner) the executed Agreement required by the Bidding Documents and any performance and payment bonds required by the Bidding Documents, or
 - 3.2. All Bids are rejected by Owner, or
 - 3.3. Owner fails to issue a Notice of Award to Bidder within the time specified in the Bidding Documents (or any extension thereof agreed to in writing by Bidder and, if applicable, consented to by Surety when required by Paragraph 5 hereof).
4. Payment under this Bond will be due and payable upon default of Bidder and within 30 calendar days after receipt by Bidder and Surety of written notice of default from Owner, which notice will be given with reasonable promptness, identifying this Bond and the Project and including a statement of the amount due.
5. Surety waives notice of any and all defenses based on or arising out of any time extension to issue Notice of Award agreed to in writing by Owner and Bidder, provided that the total time for issuing Notice of Award including extensions does not in the aggregate exceed 120 days from the Bid due date without Surety's written consent.
6. No suit or action will be commenced under this Bond prior to 30 calendar days after the notice of default required in Paragraph 4 above is received by Bidder and Surety, and in no case later than one year after the Bid due date.
7. Any suit or action under this Bond will be commenced only in a court of competent jurisdiction located in the state in which the Project is located.
8. Notices required hereunder must be in writing and sent to Bidder and Surety at their respective addresses shown on the face of this Bond. Such notices may be sent by personal delivery, commercial courier, or by United States Postal Service registered or certified mail, return receipt requested, postage pre-paid, and will be deemed to be effective upon receipt by the party concerned.
9. Surety shall cause to be attached to this Bond a current and effective Power of Attorney evidencing the authority of the officer, agent, or representative who executed this Bond on behalf of Surety to execute, seal, and deliver such Bond and bind the Surety thereby.
10. This Bond is intended to conform to all applicable statutory requirements. Any applicable requirement of any applicable statute that has been omitted from this Bond will be deemed to be included herein as if set forth at length. If any provision of this Bond conflicts with any applicable statute, then the provision of said statute governs and the remainder of this Bond that is not in conflict therewith continues in full force and effect.
11. The term "Bid" as used herein includes a Bid, offer, or proposal as applicable.

INSTRUCTIONS TO CONTRACTORS

DO NOT REMOVE FROM CONTRACT

Please observe the following in executing the attached Contract:

1. The City may contract with various categories of legal entities; and the legal requirements for proper execution (signing, witnessing, etc.) differ as to each.
 - A. If the Contract is with an individual, that individual should sign the agreement exactly as his name is set out.
 - B. Execution on behalf of a corporation, authorized corporate officer must sign, with 2nd officer signing to attest (which is 2nd officer's verification of authority and signature authenticity), plus corporate seal affixed. The following are corporate officers allowed to sign for the corporation: president; vice-president; chairman; CEO; CFO; and Treasurer. The following officers are typically authorized to attest: secretary; vice president, trust officer; clerk to board; cashier (only for banks); and their assistants or deputies.
A sole corporate officer may sign, accompanied with a notary's acknowledgement, using the corporate acknowledgement form.
 - C. If the agreement is with a partnership (General Partnership or Limited Partnership), a general partner must sign, and his/her/its signature must be notarized.
 - D. LLC "Manager" or "managing member" must sign with proper notary acknowledgement.
2. After signing the Contract, the appropriate notary's acknowledgement, either in the corporate form or individual/partnership form should be completed.
3. The Performance and Payment Bonds should be attached to the Contract package. Bonds are required by law on construction and repair contracts subject to formal bidding requirements (N.C.G.S. § 143-129 et seq. -- \$300,000.00 for construction). They should be signed by the contractor, and his signature should be acknowledged with the appropriate acknowledgement form. Next, the bonds, in approved form, must be signed by the authorized agent of the Surety Company issuing the bonds, and an executed Power of Attorney document authorizing the agent to sign must accompany the bond documents. **Bonds should not be dated.** Bonds will be dated on or after the Contract date by the City. **(Performance and Payment Bonds are not to be included in your bid)**
4. The instrument should not be dated, except by the last person executing the Contract, normally the City Clerk.
5. Non-discrimination provisions should be included with the Contract, as should applicable Certificates of Insurance with proper and timely coverage indicated.
6. All modifications or deletions should be initialed or signed by representatives of both the Contractor and the City.
7. Three (3) original copies of the Contract are sent to the Contractor for execution. These three originals should be signed and returned to the City of Raleigh for final execution, after which one (1) copy will be returned to the Contractor. Alternatively, copies of the contract may be executed through the City's DocuSign process.
8. The minority business firm listing is to be completed and submitted as part of the Bid. Additional pages may be added as needed. All backup information related to solicitation of minority participation shall be copied and submitted with the Contract. **Affidavit A and B must be submitted with your bid. Affidavit C or D must be submitted depending on MWBE commitment percentage.**

Rev.05/15/23

NORTH CAROLINA
WAKE COUNTY

Rev.07/15/2025

THIS CONTRACT (the "Contract") is entered into by and between _____, hereinafter referred to as the "Contractor", and the City of Raleigh, a North Carolina municipal corporation, hereinafter referred to as the "City" for the project entitled: Sidewalk Access Ramp Upgrades and Improvements.

WITNESSETH:

WHEREAS, the City desires to procure a contractor to perform services; and

WHEREAS, the City has completed necessary steps for retention of construction/repair services under State law and applicable City policies; and

WHEREAS, the City has agreed to engage the Contractor, and the Contractor has agreed to contract with the City, for performance of services as described, and according to the further terms and conditions, set forth herein.

NOW THEREFORE, in consideration of sums to be paid to the Contractor, and other good and valuable consideration, the Contractor and City do contract and agree as follows:

1. Description of Work

The Contractor, at its own proper cost and expense and with skill and diligence, shall furnish all labor, tools, materials and equipment and do all things necessary for the proper construction and completion ready for use of the following improvements:

- Bridge Preservation and Repair on the following bridges: Atlantic Ave (910342), Brooks Ave (910346), Stony Brook Dr (910661), South State St (911085), New Falls of Neuse (911346 & 911347), Corporation Pkwy (911351), Angel Falls Rd (911453 & 911456), Sellona St (911459)

In strict accordance with and as shown in the specifications, schedules, drawings and other documents set forth herein or incorporated by reference as follows:

- NCDOT Standards and Specifications for Roads and Structures (Latest Edition)
- NCDOT Standard Drawings
- City of Raleigh Public Utilities Handbook
- City of Raleigh Standards and Specifications
- Guidelines for Land Disturbing Activities
- ACI Specifications.

The Contractor shall further perform in accordance with the directions (not inconsistent therewith) given from time to time during the construction by the project engineer or of such other official, employee, or other agent of the City as the City may designate.

2. General Obligations of the Contractor

The Contractor will accept the prices specified in this Contract in full compensation and satisfaction for the performance of this Contract and as consideration of this Contract. The Contractor shall be responsible for all loss and damages of every kind and nature which may arise out of or an account of the performance of the work required by this Contractor, and for all risks of every description connected with the said work; and the Contractor shall be responsible for well and faithfully completing the whole work according to all applicable plans and specifications and the terms and conditions of this Contract.

3. Time of Commencement and Completion

The entire work required by this Contract shall be commenced by the Contractor not later than 10 days after the date of Notice-to-Proceed and the entire work shall be completed not later than **November 30th, 2026**. Failure to complete the work by that time will result in damages due to public inconvenience, obstruction and delay to traffic, safety, and other considerations. For each consecutive calendar day in excess of the Contract time specified above, the Contractor shall have withheld monies due it, a sum of \$1,000.00 per calendar day. If applicable, liquidated damages will be deducted/adjusted on a monthly basis at the time of the partial payment request, based on the Contractor's progress in comparison with the approved progress schedule. In the event the Contractor does not complete the Contract within the contract deadline, including any extensions of time for excusable delays as noted in Article 17 of the General Conditions portion of the Contract Documents, the Contractor shall have withheld monies due it based on the above noted procedure. Further, the Contractor shall have withheld monies due it a sum of \$1,000.00 for each consecutive calendar day of delay, until the Contract is completed.

4. Workmanship and Quality of Services/Warranties

All work under this Contract shall be done and performed to the satisfaction of the project engineer of the City of Raleigh, or of such other official, employee, or agent of the City as may be designated by the City, and such official, employee or agent designated by the City shall in all cases of dispute determine the quantity, quality, acceptability and fitness of the work and materials and of several portions thereof which are to be paid for under this Contract and shall decide and determine all questions which may arise as to the measurements, lines, levels and dimensions of the work and all questions respecting the true construction, interpretation or meaning of the plans and specifications. In case of dispute between the Contractor and the said official, employee, or agent of the City, the decision and determination of the latter shall be taken and shall be final and conclusive.

- A. The Contractor, in executing this Contract, warrants that it will be responsible for the maintenance or correction of any work completed under this Contract that may become defective due to faulty workmanship or materials for a period of one (1) year after final acceptance of the work performed.
- B. It is understood and agreed by the parties hereto that work done under this Contract shall be subject to all ordinances of the City of Raleigh relating to work done in the public streets or other public property of the City. Particularly reference is made to the provisions of Part 11, Chapter 6 of the Raleigh City Code.

5. Compensation

In consideration of the performance of this Contract and the full completion of the work required of the Contractor by the terms and conditions of this Contract, the City agrees to pay to the Contractor the not to exceed total Contract Amount of: (in written word and numerals), unless changed by a duly authorized amendment or change order.

- A. Partial payments will be made to the Contractor by the City NET thirty (30) days after presentation of a true and accurate payment application to the City as certified by the Project Engineer or agent of the City.
- B. All invoices must include the following Purchase Order Number _____.
- C. The final amount due to the Contractor will be made within thirty (30) days after the certified completion and final acceptance of all the work required by the Contract less retainage per Section 6. Payment to the Contractor by the City of the amounts so determined to be due, in accordance with this Contract, shall relieve the City from all claims for work done and materials and equipment furnished under this Contract.
- D. It is further mutually agreed between the parties that no partial payment made under this Contract shall be conclusive evidence of the performance of this Contract, either wholly or in part, and that no such payment shall be construed to be an acceptance of defective work or improper materials.

6. Retainage

This section will only apply if this public construction contract pertains to a project in which the total project costs are equal to or greater than one hundred thousand dollars (\$100,000.00).

To ensure proper performance of the Contract, the City may retain five percent (5%) of the amount of each approved partial or periodic payment application until the project work is fifty percent (50%) complete, provided that the Contractor continues to perform satisfactorily, and any non-conforming work identified in writing prior to that date has been corrected by the Contractor and accepted by the construction manager.

If the City determines the Contractor's performance is unsatisfactory, the City may reinstate retainage in the amount of five percent (5%) for each subsequent partial or periodic payment application until the Contractor's performance becomes satisfactory. The project shall be deemed fifty percent (50%) complete when the contractor's gross project invoices, excluding the value of materials stored off-site, equal or exceed fifty percent (50%) of the value of the contract, except the value of materials stored on-site shall not exceed twenty percent (20%) of the contractor's gross project invoices for the purpose of determining whether the project is fifty percent (50%) complete. Following fifty percent (50%) completion of the project, the City may also withhold additional retainage from any subsequent periodic payment, not to exceed five percent (5%), to allow the City to retain two and one-half percent (2 ½%) total retainage through the completion of the project.

Within sixty (60) days after the submission of a pay request, the City with written consent of the surety shall release to the Contractor all retainage on payments held by the City if (1) the City receives a certificate of substantial completion from the architect, engineer, or designer in charge of the project; or (2) the City receives beneficial occupancy or use of the project. However, the City may retain sufficient funds to secure completion of the project or corrections on any work. If the City retains funds, the amount

retained shall not exceed two and one-half (2 ½) times the estimated value of the work to be completed or corrected. Any reduction in the amount of the retainage on payments shall be with the consent of the contractor's surety.

Retainer provisions contained in Contractor's subcontracts may not exceed the terms and conditions for retainage provided herein. Contractors are further required to satisfy the retainage provisions of N.C.G.S. 143-134.1(b2) with regard to subcontracts for early finishing trades (structural steel, piling, caisson, and demolition) and to coordinate the release of retainage for such trades from the retainage held by the City from the Contractor pursuant to statute. Nothing shall prevent the City from withholding payment to the Contractor in addition to the amounts identified herein for unsatisfactory job progress, defective construction not remedied, disputed work, or third-party claims filed against the City or reasonable evidence that a third-party claim will be filed.

7. Notices

Except as otherwise expressly provided in this Contract, all notices, requests for payment, or other communications arising hereunder shall be sent to the following:

<u>City of Raleigh</u>	<u>Contractor</u>
Attn: Justin Massengill	Attn:
Title: Operations Supervisor	Title:
Address 1: P.O. Box 590	Address 1:
Address 2: Raleigh, NC 27602	Address 2:
Telephone: 919-996-5787	Telephone:
E-mail: justin.massengill@raleighnc.gov	E-mail:

8. Non-Discrimination

- A. To the extent permitted by North Carolina law, the Parties for themselves, their agents, officials, directors, officers, members, representatives, employees, and contractors agree not to discriminate in any manner or in any form based on actual or perceived age, mental or physical disability, sex, religion, creed, race, color, sexual orientation, gender identity or expression, familial or marital status, economic status, veteran status or national origin in connection with this Contract or its performance.
- B. The Parties agree to conform with the provisions and intent of Raleigh City Code §4-1004 in all matters related to this Contract. This provision is incorporated into the Contract for the benefit of the City of Raleigh and its residents and may be enforced by an action for specific performance, injunctive relief, or any other remedy available at law or equity. This section shall be binding on the successors and assigns of all parties with reference to the subject matter of the Contract.

9. Minority and Women Owned Business Enterprise

The City of Raleigh prohibits discrimination in any manner against any person based on actual or perceived age, race, color, creed, national origin, sex, mental or physical disability, sexual orientation, gender identity or expression, familial or marital status, religion, economic status, or veteran status. The

City maintains an affirmative policy of fostering, promoting, and conducting business with women and minority owned business enterprises.

10. Assignment

This Contract may not be assigned without the express written consent of the City.

11. Applicable Law

All matters relating to this Contract shall be governed by the laws of the State of North Carolina, without regard to its choice of law provisions, and venue for any action relating to this Contract shall be Wake County Civil Superior Court or the United States District Court for the Eastern District of North Carolina, Western Division.

12. Insurance

Contractor agrees to purchase at its own expense insurance coverages to satisfy the following minimum requirements. A certificate reflecting the following minimum coverages shall accompany this Contract:

A. Workers' Compensation Insurance:

Limits:

Workers Compensation:	Statutory for the State of North Carolina
Employers Liability:	Bodily Injury by Accident \$1,000,000 each accident
Bodily Injury by Disease	\$1,000,000 policy limit
Bodily Injury by Disease	\$1,000,000 each employee

B. Commercial General Liability:

Limits:

Each Occurrence:	\$1,000,000
Personal and Advertising Injury	\$1,000,000
General Aggregate Limit	\$2,000,000
Products and Completed Operations Aggregate	\$2,000,000

The aggregate limit must apply per project. The form of coverage must be the ISO CG 00 01 policy as approved by the State of North Carolina Department of Insurance. If a form of coverage other than the CG 00 01 is used it must be approved by the City's risk manager. Any endorsed exclusions or limitations from the standard policy must be clearly stated in writing and attached to the Certificate of Insurance.

Completed Operations coverage must be maintained for the period of the applicable statute of limitations.

C. Commercial Automobile Liability:

Limits:

\$1,000,000 combined single limit.

D. Additional Insured:

Contractor agrees to endorse the City as an Additional insured on the Commercial General Liability, Auto Liability and Umbrella Liability if being used to meet the minimum liability limits for General Liability and Automobile Liability.

The Additional Insured shall read 'City of Raleigh is named additional insured as their interest may appear'.

The Certificate Holder address should read:

City of Raleigh

Post Office Box 590

Raleigh, NC 27602-0590

E. Builders Risk Coverage:

Limits:

Minimum limit in the amount of total bid price. The Builder Risk policy must be endorsed to increase the limit of insurance for all change orders.

F. Policy Form:

Builder Risk coverage must be on a direct physical loss basis and contain no exclusion for theft, collapse or damage to foundations or underground structures, pipes or conduits.

G. Named Insured:

The Named Insured shall be The City of Raleigh, the Contractor, and all sub-contractors with a contractual assumption of responsibility for damage to the project.

All insurance companies must be licensed to do business in North Carolina and be acceptable to the City's risk manager. If the insurance company(s) is a permitted surplus lines insurer, the insurance company name, and NAIC number must be submitted to the City's risk manager for approval before commencing work. Contractor shall be required to provide the City no less than thirty (30) days' notice of cancellation, or any material change, to any insurance coverage required by this Contract.

A Certificate of Insurance (COI) must be issued by an authorized representative of the insurance carrier(s). Certificates of Insurance must have the insurance company name and NAIC number clearly identified. The acceptance of or the review of Certificates of Insurance by the City does not relieve Contractor of any requirements in the Contract to provide specific insurance coverage required by the Contract, nor does the acceptance of or review of Certificates of Insurance covenant all insurance requirements have been met.

13. Surety Bonds

If Surety Bonds are required by the City for this project, the Contractor shall have furnished and attached hereto a performance bond and a payment bond each in the penal sum of the full Contract amount covering the faithful performance of the Contract and the payment of all obligations arising hereunder, in such form and content as the City may prescribe and with surety approved by the City. Should any surety upon the bond for the performance of this Contract become unacceptable to the City, the Contractor must promptly furnish additional security as may be required from time to time by the City to protect the interests of the City and of persons, firms and corporations supplying labor or materials in the performance of the work contemplated by the Contract.

14. Indemnity

- A. To the fullest extent allowed by law, Contractor shall indemnify, defend, and hold harmless the City, its officers, officials, employees, agents, or indemnities (collectively called “Indemnified Parties”) from and against those Losses, liabilities, damages, and costs proximately caused by, arising out of, or resulting from the sole negligence of the Contractor, the Contractor’s agents, or the Contractor’s employees.
- B. In matters other than those covered by subsection 14.1. above, and to the fullest extent allowed by law, Contractor shall indemnify, defend, and hold harmless the Indemnified Parties from and against those Losses, liabilities, damages, and costs caused by, arising out of, resulting from, or in connection with the execution of the work provided for in this Agreement when the Fault of the Contractor or its Derivative Parties is a proximate cause of the Loss, liability, damage, or expense indemnified.
- C. Costs and expenses shall include attorneys’ fees, litigation or arbitration expenses, or court costs actually incurred by the Indemnified Parties to defend against third-party claims alleged in any court, tribunal, or alternative dispute resolution procedure required of any of the Indemnified Parties by law or by contract, only if the Fault of the Contractor or its Derivative Parties is a proximate cause of the attorney’s fees, litigation or arbitration expenses, or court costs to be indemnified.
- D. The Contractor’s duty to indemnify, defend, and hold harmless described hereinabove shall survive the termination or expiration of this Contract.
- E. Definitions:
 - i. For the purposes of this Section 14, the term “Loss” or “Losses” shall include, but not be limited to, fines, penalties, and/or judgments issued or levied by any local, state, or federal governmental entity.
 - ii. For the purposes of this Section 14, the term “Derivative Parties” shall mean any of the Contractor’s subcontractors, agents, employees, or other persons or entities for which the Contractor may be liable or responsible as a result of any statutory, tort, or contractual duty.

15. Communications

If communications to the public and/or City employees are required as part of the Contractor's scope of work under this Contract, then the Contractor shall work with the City in the development of a communications plan ("Communications Plan") that must first be approved by the City in writing before any such communications are delivered to the public and/or City employees.

For purposes of this Section 15, such written approval by the City shall be provided by electronic mail by the applicable City Communications Department employee who is responsible for reviewing and approving the Communications Plan, such electronic mail to be sent to the electronic mail address listed in Section 7, above, as part of the contact information for the Contractor representative identified in Section 7, above.

Among other things, the Communications Plan must establish whether the City or the Contractor will be responsible for sending any such communications to the public and/or City employees as required either by this Contract or the Communications Plan. The Communications Plan also shall include, but not be limited to, communications objectives, target audience, and deliverables (print, video, website, social, direct, or digital). The Contractor shall comply with the Communications Plan when communicating to the public and/or City employees pursuant to this Contract and the Communications Plan. All such communications shall comply with the City's brand and communications guidelines, as the same may be amended or modified from time to time.

The City's current brand and communications guidelines are incorporated into this Contract by reference and can be found on the City's website here: <https://raleighnc.gov/doing-business/city-brand-guidance-vendors>.

For purposes of this Section 15, "Communications" is defined as any public or City employee facing information presented in channels such as, but not limited to, a website, mobile applications, social media, printed materials, vehicles, billboards, and videos.

A. Communications Plan Approval:

Any materials, messaging or outreach from the Contractor related to marketing and communications of any service or effort under this Contract must first be reviewed and approved by the City's Communications Department. This is to ensure that the Communications Plan: (i) complies with the City's brand and communication guidelines; (ii) integrates with the City's other communications channels and digital strategy; (iii) meets accessibility guidelines; and (iv) conforms to communications best practices with respect to general user experience.

B. Accessibility Requirements:

For web content that the Contractor is to make accessible to the public and/or City employees as part of an approved Communications Plan that is included in the Contractor's scope of work under this Contract, all web materials including, but not limited to, tools, mobile applications, and websites, generated by, or on behalf of, the Contractor must meet at least the mid-range conformance level, AA compliance of the

current Web Content Accessibility Guidelines, as the same may be amended from time to time.

Any such web content generated by, or on behalf of the Contractor, as part of a Communications Plan associated with this Contract shall meet all standards of good cognitive web accessibility, which include the following:

- i. Using proper headings and lists
- ii. Using unique links
- iii. Using alternative text and captions
- iv. Using more white space
- v. Dividing content into more manageable pieces
- vi. Making forms manageable by breaking them into multiple, sequential steps
- vii. Providing a logical reading order
- viii. Being consistent with fonts, colors and locations of page elements
- ix. Offering keyboard access
- x. Offering content in multiple formats
- xi. Understanding minimum contrast

C. Languages:

Digital sites/ tools that are for public use/consumption, including for use by City employees, under a Communications Plan associated with this Contract must have translation module (e.g., G-translate, Weglot) so that the service is available in all languages. At minimum, Spanish translation is required on all such digital sites/tools based on low English proficiency requirements:

- i. In most cases, entities that are recipients of federal financial assistance through U.S. Department of Health and Human Services (HHS) must provide language assistance services in order to comply with their legal obligation to take reasonable steps to ensure meaningful access to their programs by persons with Limited English Proficiency (LEP).

D. Content:

For any communications content that the Contractor is required to generate, or have generated, as part of its scope of work under this Contract, the Contractor shall send such content to City Communications Department staff in raw, high-resolution format for inclusion in communications materials to be made accessible to the public and/or City employees as set forth in the Communications Plan that arises from this Contract (i.e.,

websites, mobile applications, printed materials collateral, and social media). PDF attachments shall be used only as a last resort and only after written approval by the City, with such written approval to be provided by the City in electronic mail format as described elsewhere in this Section 15.

- i. Contractor shall only provide to the City communications materials for which the City has rights to use, with written documentation of such use rights being provided to the City as requested from time to time by the City in its sole discretion.
- ii. All working files agreed upon for the specific Communications Plan shall be provided to the City Communications Department, i.e., text, graphics, charts and data, infographics, and original native files such as Illustrator, Excel, ArcGIS, etc. Following are the file format specifications:
 - a. Images: At least 300dpi for printing at actual size; 96dpi and at least 1920x1080px for digital/Web.
 - b. Video: Any video should be no less than Standard HD (1920x1080) but preferable 4k.
 - c. Text: Word document using accessibility best practices (heading structure, table of contents, and tables).

16. Advertising

The Contractor shall not use the existence of this Contract, or the name of the City, as part of any advertising without prior written approval of the City.

17. Acknowledgement of City Brand and Tree Logo Ownership and Restrictions

The City of Raleigh has developed proprietary branding (the “City Brand”) centered around the Raleigh tree mark logo (the “Tree Logo”). The City’s exclusive rights and ownership in and to the Tree Logo are protected under trademark and copyright, including U.S. Copyright Reg. No. VAu1-322-896, N.C. State Trademark Registration Reg. No. T-23070 and Federal Trademark Registration Reg. No. 5,629,347, as well as under other federal and state laws.

The Contractor acknowledges and understands that the City is not conferring any license to the Contractor under this Agreement to use or depict the Tree Logo or other aspects of the City Brand. The Contractor shall not make any use or depiction of the Tree Logo or other aspects of the City Brand without the prior express written approval of the City. In this regard, should any materials being produced by Contractor for the City under this Agreement contemplate use or depiction of the Tree Logo, including, but not limited to, printed materials, digital media, signage and/or display materials, Contractor shall proceed under the auspices and direction of the City’s Communications Department and shall comply with all guidelines and restrictions governing use or depiction of the Tree Logo.

18. Force Majeure

Except as otherwise provided in any environmental laws, rules, regulations or ordinances applicable to the parties and the services performed under this Contract, neither party shall be deemed to be in default of its obligations hereunder if and so long as it is prevented from performing such obligations by an act of war, hostile foreign actions, nuclear explosion, earthquake, hurricane, tornado, or other catastrophic natural event or act of God. Either party to the Contract must take reasonable measures and implement reasonable protections when a weather event otherwise defined as a force majeure event is forecast to be eligible to be excused from the performance otherwise required under this Contract by this provision.

19. Termination

If the Contractor fails to perform the work described herein by the time allowances provided in Section 3 or fails to provide adequate staff and resources required to properly execute said work in a workmanlike and safe manner, the City can declare the Contractor in Default.

If the Contractor fails to complete the work in the provided project duration as stated in Section 3 of this Contract, or fails to meet periodic schedules describing work sequence, or fails to comply with all appropriate local, federal, or state laws, rules and regulations, then the City may, without prejudice to any other right or remedy and after giving the Contractor and its surety a maximum of seven (7) days from delivery of a written notice, declare the Contract in default, take possession of the project and of all equipment, tools, materials thereon owned by the Contractor and call upon the surety or appropriate legal recourse to finish the work by whatever method deemed expedient.

20. Laws/Safety Standards

- A. The Contractor shall comply with all laws, ordinances, codes, rules, regulations, safety standards and licensing requirements that are applicable to the conduct of its business, including those of federal, state, and local agencies having jurisdiction and/or authority.
- B. All manufactured items and/or fabricated assemblies subject to operation under pressure, operation by connection to an electric source, or operation involving a connection to a manufactured, natural, or LP gas source shall be constructed and approved in a manner acceptable to the appropriate state inspector which customarily requires the label or re-examination listing or identification marking of the appropriate safety standard organization, such as the American Society of Mechanical Electrical Engineers for pressure vessels; the Underwriters' Laboratories and/or National Electrical Manufacturers' Association for electrically operated assemblies; or the American Gas Association for gas operated assemblies, where such approvals of listings have been established for the type(s) of devices offered and furnished. Further, all items furnished by the Contractor shall meet all requirements of the Occupational Safety and Health Act (OSHA), and state and federal requirements relating to clean air and water pollution.
- C. Contractor must comply with *North Carolina Occupational Safety and Health Standards for General Industry 13 NCAC 07F (29CFR 1910)*. In addition, Contractor shall comply with all applicable occupational health and safety and environmental rules and regulations.

- D. The Contractor shall effectively manage its safety and health responsibilities including:
- i. Accident Prevention:
Prevent injuries and illnesses to its employees and others on or near the job site. Contractor managers and supervisors shall ensure personnel safety by strict adherence to established safety rules and procedures.
 - ii. Environmental Protection:
Protect the environment on, near, and around the work site by compliance with all applicable environmental regulations.
 - iii. Employee Education and Training:
Provide education and training to all contractor's employees before they are exposed to potential workplace or other hazards as required by specific OSHA Standards.

21. Applicability of North Carolina Public Records Law

Notwithstanding any other provisions of this Contract, this Contract and all materials submitted to the City by the Contractor are subject to the public records laws of the State of North Carolina and it is the responsibility of the Contractor to properly designate materials that may be protected from disclosure as trade secrets under North Carolina law as such and in the form required by law prior to the submission of such materials to the City. Contractor understands and agrees that the City may take any and all actions necessary to comply with federal, state, and local laws and/or judicial orders and such actions will not constitute a breach of the terms of this Contract. To the extent that any other provisions of this Contract conflict with this section, the provisions of this section shall control.

22. Miscellaneous

- A. The Contractor shall be responsible for the proper custody and care of any property furnished or purchased by the City for use in connection with the performance of this Contract and will reimburse the City for the replacement value of its loss or damage. The Contractor shall keep the job sites and surrounding area reasonably free from rubbish at all times and shall remove debris from the site from time to time or when directed to do so by the City. Before final inspection and acceptance of the project, the Contractor shall thoroughly clean the job sites, and completely prepare the project and site for use by the City.
- B. The Contractor shall be considered to be an independent contractor and as such shall be wholly responsible for the work to be performed and for the supervision of its employees. Nothing herein is intended or will be construed to establish any agency, partnership, or joint venture. Contractor represents that it has, or will secure at its own expense, all personnel required in performing the services under this Contract. Such employees shall not be employees of or have any individual contractual relationship with the City.
- C. This Contract may be amended only by written agreement of the parties executed by their authorized representatives.

23. Right of Audit and Examination of Records

- A. The City may conduct an audit of any services performed and fees paid subject to this Contract. The City, or its designee, may perform such an audit throughout the contract period and for three (3) years after termination thereof or longer if otherwise required by law.
- B. The Contractor and its agents shall maintain all books, documents, papers, accounting records, contract records and such other evidence as may be appropriate to substantiate costs incurred under this Contract. The City, or its designee, shall have the right to, including but not limited to: review and copy records; interview current and former employees; conduct such other investigation to verify compliance with Contract terms; and conduct such other investigation to substantiate costs incurred by this Contract.
- C. "Records" shall be defined as data of every kind and character, including but not limited to books, documents, papers, accounting records, contract documents, information, and materials that, in the City's sole discretion, relate to matters, rights, duties or obligations of this Contract.
- D. Records and employees shall be available during normal business hours upon advanced written notice. Electronic mail shall constitute written notice for purposes of this section.
- E. Contractor shall provide the City or its designee reasonable access to facilities and adequate and appropriate workspace for the conduct of audits.
- F. The rights established under this section shall survive the termination of the Contract, and shall not be deleted, circumvented, limited, confined, or restricted by contract or any other section, clause, addendum, attachment, or the subsequent amendment of this Contract.
- G. The Contractor shall reimburse the City for any overcharges identified by the audit within ninety (90) days of written notice of the City's findings.
- H. If an audit discloses overpricing or overcharges by the Contractor or Subcontractor in excess of one percent (1%) of the total contract billings, the Contractor shall reimburse the City for the cost of the audit.
- I. Contractor shall ensure that all contracts with any subcontractors provide the City with an equivalent right to audit as contained herein.
- J. Contractor shall, upon request, provide any records associated with this engagement to the North Carolina State Auditor that are necessary to comply with the provisions of G.S. § 147-64.7.

24. Incorporation of Documents/Complete Agreement

This Contract, and any documents incorporated below, represent the entire Contract between the parties and suspend all prior oral or written statements, agreements or Contracts.

Specifically incorporated into this Contract are the following attachments, or if not physically attached, are incorporated fully herein by reference:

- Bid Advertisement/City-issued bid document
- Contractor's Bid-response document
- Procedure for N.C. Sales Tax Reporting
- Performance Bond (w/Power-of-Attorney)
- Payment Bond (w/Power-of-Attorney)
- Certificate of Insurance
- General Conditions
- Special or Supplemental Conditions
- Job Specifications
- SDMWOB Affidavits/documentation
- Other (Describe) _____

In case of conflict between this Contract and any of the incorporated attachments or references listed above, the terms of this Contract shall prevail.

25. E – Verify

Contractor shall comply with *E-Verify*, the federal E-Verify program operated by the United States Department of Homeland Security and other federal agencies, or any successor or equivalent program used to verify the work authorization of newly hired employees pursuant to federal law and as in accordance with N.C.G.S. §64-25 *et seq.* In addition, to the best of Contractor's knowledge, any subcontractor employed by Contractor as a part of this contract shall be in compliance with the requirements of E-Verify and N.C.G.S. §64-25 *et seq.* In cases of conflict between this Contract and any of the above incorporated attachments or references, the terms of this Contract shall prevail.

26. Iran Divestment Act Certification

Contractor certifies that, as of the date listed below, it is not on the final divestment list as created by the State Treasurer pursuant to N.C.G.S. § 147-86.55, *et seq.* In compliance with the requirements of the Iran Divestment Act and N.C.G.S. § 147-86.60, Contractor shall not utilize in the performance of the Contract any subcontractor that is identified on the final divestment list.

27. Companies Boycotting Israel Divestment Act Certification

Contractor certifies that it has not been designated by the North Carolina State Treasurer as a company engaged in the boycott of Israel pursuant to N.C.G.S. 147-86.81.

The remainder of this page is left blank intentionally.

IN WITNESS WHEREOF, the parties hereto have executed this Contract by digital signature, under seal, on the respective dates below, and this Contract shall be effective upon the date of the City's signature.

CONTRACTOR:

CITY:

CITY OF RALEIGH
a North Carolina municipal corporation

By:

By:

_____(SEAL)
Signature

Signature

Name

Name

Title

Title

Department

Date of Signature

Date of Signature

ATTEST:

ATTEST:

Signature

_____(SEAL)
City Clerk (or designee)

Name

Title

This instrument has been pre-audited in the manner required by the Local Government Budget and Fiscal Control Act.

Chief Financial Officer (or designee)

AFFIDAVIT

**STATE OF NORTH CAROLINA
COUNTY OF WAKE**

NOW COMES Affiant, _____, being duly authorized by law and on behalf of _____ (“Contractor”) after first being duly sworn hereby swears or affirms as follows:

1. Contractor has submitted a bid for contract or desires to enter into a contract with the City of Raleigh;

2. As part of his/her duties and responsibilities pursuant to said bid and/or contract, Contractor attests that he/she is aware of and in compliance with the requirements of E-Verify, the federal program operated by the United States Department of Homeland Security, and Article 2 of Chapter 64 of the North Carolina General Statutes, to include (mark which applies):

- ___ After hiring an employee to work in the United States, verifies the work authorization of said employee through E-Verify and retain the record of the verification of work authorization while the employee is employed and for one year thereafter; or
- ___ Employs less than twenty-five (25) employees in the State of North Carolina.

3. As part of his/her duties and responsibilities pursuant to said bid and/or contract, Contractor attests that to the best of his/her knowledge any subcontractors employed as a part of this bid and/or contract are in compliance with the requirements of E-Verify and Article 2 of Chapter 64 of the North Carolina General Statutes.

This the _____ day of _____, 2026.

Affiant

Sworn to and subscribed before me, this the _____ day of _____, 2026.

[OFFICIAL SEAL] _____, Notary Public

My Commission Expires: _____

INFORMATION FOR BIDDERS REGARDING COMPLIANCE WITH THE CITY OF RALEIGH'S MINORITY AND WOMEN-OWNED BUSINESS ENTERPRISE (MWBE) PROGRAM

Policy

In accordance with North Carolina law, the City of Raleigh encourages and provides an equal opportunity for Certified Minority and Women-Owned Business Enterprises (MWBE) to participate in all aspects of the City's contracting and procurement programs.¹ The prime contractor or a first-tier subcontractor on a construction manager at risk (CMAR) project (collectively, "Bidder") shall be required to identify participation of MWBE businesses in its proposal, and document how that participation will be achieved. Bidders are subject to the City's MWBE subcontracting requirements (including good faith efforts as applicable), regardless if a Bidder is itself a Certified MWBE.²

The City has an aspirational goal of 15% of the total contract amount to be performed by MWBE businesses in contracts awarded by the City for: (i) construction and building projects of \$300,000 or more; and (ii) construction and building projects of \$100,000 or more that have any state funding.

Definitions

Certified Minority Business (MWBE)

A business which:

- a. At least fifty-one percent (51%) is owned by one or more Minority Persons or Socially and Economically Disadvantaged Individuals; or in the case of a corporation, in which at least fifty-one percent (51%) of the stock is owned by one or more Minority Persons or Socially and Economically Disadvantaged Individuals;
- b. The management and daily business operations are controlled by one or more Minority Persons or Socially and Economically Disadvantaged Individuals; and
- c. Is certified in one of the MWBE categories as defined by the NC Department of Administration/Historically Underutilized Business (HUB) and the NC Department of Transportation/Disadvantaged Business Enterprise (DBE).

Minority Person

A person who is a citizen or lawful permanent resident of the United States and who is:

- a. Black, that is, a person having origins in any of the black racial groups in Africa;
- b. Hispanic, that is, a person of Spanish or Portuguese culture with origins in Mexico, South or Central America, or the Caribbean Islands, regardless of race;
- c. Asian American, that is, a person having origins in any of the original peoples of the Far East, Southeast Asia, Asia, the Indian subcontinent, or the Pacific Islands;
- d. American Indian, that is, a person having origins in any of the original peoples of North America; or
- e. Non-minority Female.

Socially and Economically Disadvantaged Individual

Socially disadvantaged individuals are those who have been subjected to racial or ethnic prejudice or cultural bias because of their identity as a member of a group without regard to their individual qualities. Economically disadvantaged individuals are those socially disadvantaged individuals whose ability to compete in the free enterprise system has been impaired due to diminished capital and credit opportunities as compared to others in the same business area who are not socially disadvantaged.³

¹ See, N.C.G.S. §§ 143-128.2, 143-128.4, 143-129, and 143-131.

² See, City of Raleigh SOP 505-2.

³ See, 15 U.S.C. 637.

Bidder Responsibilities

Bidders agree to comply with all the terms and conditions of the City of Raleigh's Minority and Women-Owned Business Enterprise (MWBE) Program. Bidders must use good faith efforts (if applicable) to meet participation goals through the award of subcontracts to certified MWBE businesses consistent with City policy and North Carolina law.

Pre-Bid Opening

The City's Solicitation Documents include forms that: (a) capture information about MWBEs and any other subcontractors or suppliers that a Bidder intends to use on a contract ("Identification of MWBE Participation") and (b) affidavits to be completed by the Bidder.

Identification of MWBE Participation

The "Identification of MWBE Participation" must be completed by the Bidder on the City's form and submitted with its bid. If the project work is to be self-performed by the Bidder, the Bidder must so designate by checking the appropriate box on the form. For all Bidders which will not be self-performing the project work, the "Identification of MWBE Participation" form must be completed in its entirety. The Bidder must list on the City's form all MWBE businesses which will be construction subcontractors, vendors, or suppliers (collectively, "Subcontractors") on the project, and the total dollar value of its bid that will be performed by MWBEs. The failure to complete the "Identification of MWBE Participation" form in its entirety, or the failure to submit a completed "Identification of MWBE Participation" form with its bid, will render the bid non-responsive and the Bidder's bid will not be considered for award. The City will only credit MWBE participation for those Subcontractors listed on the "Identification of MWBE Participation" form.

Affidavit A: Listing of Good Faith Efforts

If the Bidder intends to subcontract any portion of the project work on a contract, an Affidavit A must be properly executed and submitted with its bid, listing the good faith efforts the Bidder made to achieve MWBE subcontracting goals for the contract prior to submitting its bid. The Affidavit A must be completed using the City's form. A minimum of fifty (50) good faith efforts points is required, the failure to achieve at least 50 points is grounds for rejection of a bid.

Affidavit B: Intent to Perform Contract with Own Workforce

In lieu of an Affidavit A, a Bidder that intends to perform 100% of the project work on a contract with its own current workforce may submit an Affidavit B with its bid. In submitting an Affidavit B, a Bidder certifies that the Bidder does not customarily subcontract elements of this type of project, and normally performs, has the capability to perform, and will perform all elements of the project work on the contract with its own current workforce. The Affidavit B must be completed using the City's form.

The failure to submit a properly executed Affidavit A or Affidavit B with a bid will render the bid non-responsive and the bid will not be considered for award.

Bid Opening

At the project bid opening, the total MWBE participation for each bid will be recorded. Upon being named the apparent low bidder, the Bidder must comply with the following:

- a. If the Bidder submitted an Affidavit B with its bid indicating its intent to perform 100% of the project work on the contract with its own current workforce, then the Bidder is not required to resubmit its Affidavit B or to submit any additional affidavits (i.e., Affidavit C or Affidavit D). The City, in its discretion, may request that the Bidder submit additional information or documentation, including, but not limited to, information relating to the Bidder's subcontracting history and its ability to perform all elements of the project work on the contract with its own current workforce.

- b. If the Bidder submitted an Affidavit A with its bid and the amount of MWBE participation as a percentage of the total contract price meets or exceeds the applicable goal, then the Bidder must submit to the City an Affidavit C within three (3) business days after being notified by City Staff that it is the apparent low bidder. The Bidder must complete the Affidavit C in its entirety using the City's form.
- c. If the Bidder submitted an Affidavit A with its bid and the amount of MWBE participation as a percentage of the total contract price does not meet the applicable goal, then the Bidder must submit an Affidavit D to the City within three (3) business days after being notified by City Staff that it is the apparent low bidder. The Bidder must complete Affidavit D in its entirety on the City's form. In conjunction with the Affidavit D, the Bidder must include supplemental documentation of the good faith efforts made to meet the applicable goal. The City, in its discretion, may request that the Bidder submit additional information or documentation, including, but not limited to, information or documentation relating to any good faith efforts claimed by the Bidder, and completion of the City's Good Faith Negotiation Form and Solicitation Form. Good faith efforts can be demonstrated using, among other factors, the following:
 - i. Attending pre-solicitation or pre-bid meetings that are scheduled by the City to inform MWBE firms of contracting, subcontracting, and supply opportunities.
 - ii. Advertising in general circulation, trade association, or minority-focus media concerning subcontracting opportunities.
 - iii. Providing written notice, to a reasonable number of specific MWBE firms that their interest in the contract is being solicited, at least 10 days before bids are due, to allow MWBE firms time to participate.
 - iv. Following up initial solicitation of interest by contacting MWBE firms to determine with certainty whether the MWBE firms are interested.
 - v. Identifying and selecting portions of the work to be performed by MWBE firms in order to increase the likelihood of MWBE participation (including where appropriate, breaking down contracts into economically feasible units to facilitate MWBE participation).
 - vi. Providing interested MWBE firms with equal access to plans, specifications, and requirements of the contract.
 - vii. Negotiating fairly with interested MWBE firms, not rejecting MWBE firms as unqualified without sound reasons based on a thorough investigation of their capabilities.
 - viii. Using the services of the City's MWBE office; available minority community organizations; minority contractors' groups; local, state, and federal minority business offices; and other organizations that provide assistance in the recruitment and placement of MWBE firms.
 - ix. Assisting interested MWBE firms in need of equipment, loan capital, lines of credit or joint pay agreements to secure loans, supplies or letters of credit, including waiving credit that is ordinarily required.
 - x. Assisting interested MWBE firms in obtaining bonding, insurance, or providing alternatives to bonding or insurance for Subcontractors.
 - xi. Negotiating joint venture and partnership arrangements with minority businesses to increase the opportunities for minority participation when possible.
 - xii. Provide for quick pay agreements and policies to enable minority contractors and suppliers to meet cash flow demands.

For each unmet MWBE participation goal, for which an Affidavit D is submitted, a Bidder must earn at least fifty (50) good faith efforts points. The failure to achieve at least fifty (50) points is grounds for rejection of a bid. All

actions necessary to earn good faith efforts points must occur prior to bid opening. In determining whether a Bidder has made good faith efforts, the City will evaluate the efforts made by the Bidder and will determine compliance with regard to quantity, intensity, and results of these efforts prior to recommendation of award.

Post-Award

Payment

For purposes of this section the word "Contractor" means both the prime contractor and the CMAR for CMAR projects. The Contractor must submit a completed **Payment Affidavit - Subcontractor / Supplier Utilization Form** with each payment application, including periodic payments and final payment. Payment applications will not be processed by the City until a completed Payment Affidavit – Subcontractor/ Supplier Utilization Form is submitted. Within seven (7) days of receipt by the Contractor of a periodic or final payment from the City, the Contractor must pay each first-tier Subcontractor based on work completed or services provided under each subcontract. If the Contractor has made a quick pay commitment with any MWBE Subcontractor, they must comply with the provisions of their quick pay commitment.

Changing a Certified MWBE Subcontractor

If the situation arises that it becomes necessary to terminate, replace, or reduce the work of a MWBE Subcontractor counted toward a committed MWBE subcontracting goal, the Contractor must submit a completed **Request to Change MWBE Subcontractor** form to the applicable department project manager and the City's MWBE Program Manager. Any change in the work of a MWBE Subcontractor, including its termination and/or replacement, must first be approved by the City based upon good cause shown. Any further explanation or detail to the City in addition to what is identified in the Request to Change MWBE Subcontractor form must be on company letterhead. Good faith efforts shall apply to the selection of any substitute Subcontractor.

ACKNOWLEDGMENT OF MWBE POLICY
[PURSUANT TO N.C.G.S. § 143-128.2]

The City’s policy is to encourage bidders in the participation of MWBE businesses. A presentation of that policy has been made at the pre-bid or pre-proposal conference. By submission of a bid or proposal in response to this solicitation, the Bidder consents to all the terms and conditions of the City of Raleigh Minority and Women-Owned Business Enterprise (MWBE) Policy. A copy of the policy may be provided upon request by the Business Engagement & Opportunities Division, or online at www.raleighnc.gov.

Bidder recognizes that the City of Raleigh encourages and provides equal opportunity for MWBE businesses to participate in all aspects of the City’s contracting and procurement. The City’s MWBE participation aspirational goal is at least fifteen percent (15%) of the total contract amount to MWBEs on construction projects of \$300,000 or more and building related contracts of \$100,000 or more that include any State funding. The Bidder on the subject Contract/Proposal must document good faith efforts to provide meaningful participation by MWBEs in the performance of the Contract. Bidder agrees that the City may reject a bid for MWBE Policy violations, including but not limited to, providing inaccurate information or for failure to provide required MWBE documentation.

The Prime Contractor will be required to identify participation of MWBE businesses and how that participation will be achieved. Bidder must identify anticipated subcontractors, including any Minority & Women-Owned Businesses, intended to be used. Bidder further agrees, if awarded a Contract, it will, upon request, submit to the City, the proper affidavit identifying the workforce actually utilized on the Contract. All MWBE related bid documents have been provided to the Bidder. MWBE information provided by the Bidder is subject to the NC Public Records Act. Bidder acknowledges that the City must be notified of any change of subcontractors, suppliers, or subconsultants.

To the extent permitted by North Carolina law, the Bidder for themselves, their agents, officials, directors, officers, members, representatives, employees, and contractors agree not to discriminate in any manner or in any form based on actual or perceived age, mental or physical disability, sex, religion, creed, race, color, sexual orientation, gender identity or expression, familial or marital status, economic status, veteran status or national origin in connection with this Contract/Proposal or its performance. The Bidder agrees to conform with the provisions and intent of Raleigh City Code §4-1004 in all matters related to this Contract/Proposal. This provision is incorporated herein for the benefit of the City of Raleigh and its residents and may be enforced by an action for specific performance, injunctive relief, or any other remedy available at law or equity. This section shall be binding on the successors and assigns of all parties with reference to the subject matter of the Contract/Proposal.

I have read and understand the City of Raleigh’s MWBE policy.

Signature

Printed Name and Title

Company

Date

AFFIDAVIT A
Listing of Good Faith Efforts (GFE)

Affidavit of _____
(Name of Bidder)

Project Name			
Project Number			
Total Project Bid		Bid Submittal Date	

Total Available GFE Points: 155		Minimum Number GFE Points Required: 50
POINTS	GOOD FAITH EFFORT (GFE)	
<input type="checkbox"/>	10	Contacted MWBE businesses that reasonably could have been expected to submit a quote and that were known to the contractor or available on State or local government-maintained lists, at least 10 days before the bid date and notified them of the nature and scope of the work to be performed.
<input type="checkbox"/>	10	Made construction plans, specifications and requirements available for review by prospective MWBE businesses or provided these documents at least 10 days before bids are due.
<input type="checkbox"/>	15	Broken down or combined elements of work into economically feasible units to facilitate MWBE business participation.
<input type="checkbox"/>	10	Worked with MWBE businesses trade, community, or contractor organizations identified by the MWBE Office and included in the bid documents that provide assistance in recruitment of MWBE businesses.
<input type="checkbox"/>	10	Attended pre-bid meetings schedule by the public owner.
<input type="checkbox"/>	20	Provided assistance in getting required bonding or insurance or provided alternatives to bonding or insurance for subcontractors.
<input type="checkbox"/>	15	Negotiated in good faith with interested MWBE businesses and did not reject them as unqualified without sound reasons based on their capabilities. Any rejection of a MWBE business based on lack of qualification should have the reasons documented in writing.
<input type="checkbox"/>	25	Provided assistance to MWBE businesses in need of equipment, loan capital, lines of credit, or joint pay agreements to secure loans, supplies, or letters of credit, including waiving credit that is ordinarily required. Assisted MWBE businesses in obtaining the same unit pricing with the bidder's suppliers in order to help MWBE businesses in establishing credit.
<input type="checkbox"/>	20	Negotiated joint venture and partnership arrangements with MWBE businesses in order to increase opportunities for MWBE businesses participation on a public construction or repair project when possible.
<input type="checkbox"/>	20	Provided quick pay agreements and policies to enable MWBE business contractors and suppliers to meet cash flow demands.
Total GFE Points _____		

The undersigned certifies the preceding representation is a true and accurate statement of Good Faith Efforts made toward the participation of MWBE businesses in the performance of this Project/Contract. Failure to provide accurate and truthful information is a violation of the City of Raleigh MWBE Policy and may result in the sanctions prescribed therein.

This the ____ of _____, 20 ____
Signature _____ Printed Name/Title _____

AFFIDAVIT B
Intent to Perform Contract with Own Workforce

Affidavit of _____
(Name of Bidder)

Project Name			
Total Project Bid		Bid Submittal Date	
Project Number			
<input type="checkbox"/> PRIME IS MWBE	Classification: _____	<input type="checkbox"/> Certified with NCHUB	<input type="checkbox"/> Certified with NCDOT-DBE

*MWBE Classifications: American Indian (AI), Asian American (AA), Black/African-American (B), Hispanic (H), Non-Minority Female (NMF), Socially/Economic Disadvantaged (D)

The Bidder hereby certifies having read and understood the City of Raleigh MWBE Policy, and affirms that it is the intent of the Bidder to **perform 100% of the work** required for the above-named Contract.

In making this certification, the Bidder states that the Bidder does not customarily subcontract elements of this type project, and normally performs and has the capability to perform and will perform **all elements of work on this project** with the Bidder's own current work forces; and

The Bidder agrees to provide any additional information or documentation requested by the City of Raleigh in support of the above statement. If additional scopes of work are added after the Bidder has been awarded the Contract, then the Bidder agrees to make a Good Faith Effort to utilize Minority and Women-Owned Business Enterprises (MWBEs), as applicable, where possible.

The undersigned hereby certifies that he or she has read this certification and is authorized to bind the Bidder to the commitments herein contained.

Date: _____ Name of Authorized Officer: _____

Signature: _____

Title: _____

State of North Carolina, County of _____

Subscribed and sworn to before me this _____ day of _____ 20__

Notary Public _____ My commission expires _____

SEAL

AFFIDAVIT C
MWBE SUBCONTRACTOR UTILIZATION COMMITMENT

This affidavit is to be provided by the Prime Contractor within three (3) business days after notification by the City of being the apparent lowest, responsible, responsive bidder (LRRB) if the portion of the work to be performed by MWBE Businesses equals or exceeds fifteen percent (15%) of the total contract price. *Copy this Form as needed.*

SECTION 1. PROJECT INFORMATION

Project Name			
Project Number		City Department	
Project Manager			
Phone Number		Email Address	
Bidder		Contact Name	
Phone Number		Email Address	
<input type="checkbox"/> PRIME IS MWBE	Classification: _____ <input type="checkbox"/> Certified with NCHUB <input type="checkbox"/> Certified with NCDOT-DBE	Bid Submittal Date	
Prime to Perform	\$ _____	Prime to Perform	_____ %

Total Base Bid Amount \$ _____

Total Contract Amount (including Contingency) \$ _____

Total MWBE Subcontractor / Supplier Utilization \$ _____

Percent MWBE Subcontractor Utilization (Total MWBE \$ divided by Total Base Bid) _____ %

SECTION 2. MWBE SUBCONTRACTORS

Complete the chart below for all MWBE subcontractors to be used on this Project/Contract regardless of dollar amount.

Company Name	Contact Information (Name, Email, Phone)	MWBE Classification	Description of Services	Percentage of Total Contract	Total Projected Utilization (\$)

*MWBE Classifications: American Indian (AI), Asian American (AA), Black/African-American (B), Hispanic (H), Non-Minority Female (NMF), Socially/Economic Disadvantaged (D)

Letters of Intent Submitted Upon Notice from the City

Within three (3) Business Days after receiving a request from the City (or within such longer time as may be communicated by the City in writing), Bidders must submit a separate Letter of Intent for each MWBE listed on Affidavit C. Each Letter of Intent must be executed by both the MWBE and the Bidder. The City shall not count proposed MWBE utilization for which it has not received a Letter of Intent by this deadline.

Adding Subcontractors or Suppliers After Submitting This Form

Nothing in this Affidavit shall be deemed to preclude you from entering into subcontracting arrangements after submission of this form. However, per the City of Raleigh MWBE Policy, you must comply with the following:

- You must maintain the level of MWBE participation proposed on this Affidavit throughout the duration of the Contract, except as may be otherwise specifically allowed by the City.
- If you need to terminate or replace a MWBE, you must complete a Request to Change a MWBE Subcontractor Form.
- If the scope of work on the Contract increases, or if you elect to subcontract any portion of work not identified on this form as subcontracted, then you must comply with City of Raleigh MWBE Policy, including Good Faith Efforts.
- A Letter of Intent must also be submitted for each MWBE you add subsequent to contract award.

Signature

Your signature below indicates that the undersigned firm certifies and agrees that:

- a. You have complied with all provisions of the City of Raleigh MWBE Policy;
- b. The information provided is a true and accurate statement of MWBE businesses intended to be used as subcontractors, subconsultants, or suppliers in the performance of this Project/Contract; and
- c. Failure to provide accurate and truthful information or to properly document such compliance in the manner and within the time periods established by the City of Raleigh MWBE Policy shall constitute a violation of the City of Raleigh MWBE Policy and may result in the sanctions prescribed therein, including rejection of your bid.

This the ___ of _____, 20 _____

Signature

Printed Name/Title

AFFIDAVIT D
GOOD FAITH EFFORTS (GFE) AND STATEMENT OF GFE COMPLIANCE

This affidavit is to be provided by the Prime Contractor within three (3) business days after notification by the City of being the apparent lowest, responsible, responsive bidder (LRRB) if the Bidder has not fully met the established MWBE Goal (15%) for this Project. The Bidder must document it has met the GFE requirements by completing this Form. GFE Points will be calculated independently by the City.

SECTION 1. PROJECT INFORMATION

Project Name			
Project Number		City Department	
Project Manager			
Phone Number		Email Address	
Bidder		Contact Name	
Phone Number		Email Address	
<input type="checkbox"/> PRIME IS MWBE	Classification: _____ <input type="checkbox"/> Certified with NCHUB <input type="checkbox"/> Certified with NCDOT-DBE	Bid Submittal Date	
Prime to Perform	\$ _____	Prime to Perform	_____ %

Total Base Bid Amount \$ _____

Total Contract Amount (including Contingency) \$ _____

Total MWBE Subcontractor / Supplier Utilization \$ _____

Percent MWBE Subcontractor Utilization (Total MWBE \$ divided by Total Base Bid) _____ %

SECTION 2. MWBE SUBCONTRACTORS

Complete the chart below for all MWBE subcontractors to be used on this Project/Contract regardless of dollar amount.

Company Name	Contact Information (Name, Email, Phone)	MWBE Classification	Description of Services	Percentage of Total Contract	Total Projected Utilization (\$)

*MWBE Classifications: American Indian (AI), Asian American (AA), Black/African-American (B), Hispanic (H), Non-Minority Female (NMF), Socially/Economic Disadvantaged (D)

SECTION 3. GOOD FAITH EFFORTS

Below is a list of Good Faith Efforts as defined in the City’s MWBE Policy. To the left of each item is the number of points assigned to that item. Please place an “X” in the first column for each item you are claiming credit. Please provide any documentation, if available. Failure to achieve the minimum number of GFE points stated in the box below may constitute grounds for rejection of your bid.

NOTE: All actions necessary to earn GFE Points must be undertaken prior to Bid Opening.

Total Available GFE Points: 155		Minimum Number GFE Points Required: 50
POINTS		GOOD FAITH EFFORT (GFE)
<input type="checkbox"/>	10	Contacted MWBE businesses that reasonably could have been expected to submit a quote and that were known to the contractor or available on State or local government-maintained lists, at least 10 days before the bid date and notified them of the nature and scope of the work to be performed.
<input type="checkbox"/>	10	Made the construction plans, specifications and requirements available for review by prospective MWBE businesses or providing these documents to them at least 10 days before the bids are due.
<input type="checkbox"/>	15	Broken down or combined elements of work into economically feasible units to facilitate MWBE business participation.
<input type="checkbox"/>	10	Worked with MWBE businesses trade, community, or contractor organizations identified by the MWBE Office and included in the bid documents that provide assistance in recruitment of MWBE businesses.
<input type="checkbox"/>	10	Attended pre-bid meetings schedule by the public owner.
<input type="checkbox"/>	20	Provided assistance in getting required bonding or insurance or provided alternatives to bonding or insurance for subcontractors.
<input type="checkbox"/>	15	Negotiated in good faith with interested MWBE businesses and did not reject them as unqualified without sound reasons based on their capabilities. Any rejection of a MWBE business based on lack of qualification should have the reasons documented in writing.
<input type="checkbox"/>	25	Provided assistance to MWBE businesses in need of equipment, loan capital, lines of credit, or joint pay agreements to secure loans, supplies, or letters of credit, including waiving credit that is ordinarily required. Assisted MWBE businesses in obtaining the same unit pricing with the bidder’s suppliers in order to help MWBE businesses in establishing credit.
<input type="checkbox"/>	20	Negotiated joint venture and partnership arrangements with MWBE businesses in order to increase opportunities for MWBE businesses participation on a public construction or repair project when possible.
<input type="checkbox"/>	20	Provided quick pay agreements and policies to enable MWBE business contractors and suppliers to meet cash flow demands.
Total GFE Points (Claimed by Bidder) _____		Total GFE Points (Assessed by City) _____

Letters of Intent Submitted Upon Notice from the City

Within three (3) Business Days after receiving a request from the City (or within such longer time as may be communicated by the City in writing), Bidders must submit a separate Letter of Intent for each MWBE listed on this Affidavit D. Each Letter of Intent must be executed by both the MWBE and the Bidder. The City shall not count proposed MWBE utilization for which it has not received a Letter of Intent by this deadline.

Adding Subcontractors or Suppliers After Submitting This Form

Nothing in this Affidavit shall be deemed to preclude you from entering into subcontracting arrangements after submission of this form. However, per the City of Raleigh MWBE Policy, you must comply with the following:

- You must maintain the minimum level of MWBE participation proposed on this Affidavit throughout the duration of the Contract, except as may be otherwise specifically allowed by the City.
- If you need to terminate or replace a MWBE, you must complete a Request to Change a MWBE Subcontractor Form.
- If the scope of work on the Contract increases, or if you elect to subcontract any portion of work not identified on this form as subcontracted, then you must comply with City of Raleigh MWBE Policy, including Good Faith Efforts.
- A Letter of Intent must also be submitted for each MWBE you add subsequent to contract award.

Signature

Your signature below indicates that the undersigned firm certifies and agrees that:

- a. You have complied with all provisions of the City of Raleigh MWBE Policy;
- b. The information provided is a true and accurate statement of Certified MWBE businesses intended to be used as subcontractors, subconsultants, or suppliers in the performance of this Project/Contract; and
- c. Failure to provide accurate and truthful information or to properly document such compliance in the manner and within the time periods established by the City of Raleigh MWBE Policy shall constitute a violation of the City of Raleigh MWBE Policy and may result in the sanctions prescribed therein, including rejection of your bid.

This the ___ of _____, 20 _____

Signature

Printed Name/Title

Letter of Intent

In accordance with City of Raleigh MWBE Policy, within three (3) Business Days after receiving a request from the City (or within such longer time as may be communicated by the City in writing), a Bidder must submit a separate Letter of Intent for each MWBE subcontractor listed on Affidavit C or Affidavit D, as may be applicable.

Project Name	
Project Number	

Section 1: TO BE COMPLETED BY THE BIDDER					
Name of Bidder					
Address					
Contact Person					
Telephone		E-mail		Fax	

If the Bidder has entered into a Quick Pay Agreement, in association with this Letter of Intent and as defined in the City's MWBE Policy, please attach a copy of the executed Agreement with the undersigned MWBE.

Identify in complete detail the scope of work to be performed or item(s) to be supplied by the MWBE.

Cost of Work to be Performed by MWBE \$ _____

Section 2: TO BE COMPLETED BY MWBE SUBCONTRACTOR					
Name of MWBE					
Address					
Contact Person					
Telephone		E-mail		Fax	

Upon execution of a Prime Contract with the City for the above referenced project, the Bidder certifies that it intends to utilize the MWBE listed above, and that the description, cost and percentage of work to be performed by the MWBE as described above is accurate. The MWBE firm certifies that it has agreed to provide such work/supplies for the amount stated above.

BIDDER		
	Signature	Date
	Print Name and Title	
MWBE		
	Signature	Date
	Print Name and Title	

CONTRACT SUBCONTRACTOR IDENTIFICATION FORM

Building Project/Construction Contracts

(This form **MUST** be submitted within 30 days after award of the Contract)

This Final Subcontractor Identification Form is to provide a list of all subcontractors that the Contractor will use in the performance of the Contract with the City, in accordance with NCGS §143-128.2. *Copy this Form as needed.*

CONTRACTOR NAME			
PROJECT NAME			
PROJECT NUMBER		CITY DEPARTMENT	
<input type="checkbox"/> PRIME IS MWBE	Classification: _____ <input type="checkbox"/> Certified with NCHUB <input type="checkbox"/> Certified with NCDOT-DBE	CONTRACT AWARD DATE	

MWBE Classifications: American Indian (AI), Asian American (AA), Black/African American (B), Hispanic (H), Non-Minority Female (NMF), Socially/Economic Disadvantaged (D)

WORK TO BE SELF-PERFORMED

Check this box **only** if you intend to perform 100% of the work on this Project/Contract with your own current work forces, and you normally perform and have the capability to perform all elements of this work on this Project/Contract with your own current work forces.

ALL CONTRACT SUBCONTRACTORS

Complete the chart below for **all** subcontractors that will be used on this Contract regardless of dollar amount.

Company Name	Contact	Description of Service/Trade	Total (\$)
	Name:		
<input type="checkbox"/> Certified MWBE <input type="checkbox"/> Registered Raleigh SCS	E-mail:	Address:	
	Name:		
<input type="checkbox"/> Certified MWBE <input type="checkbox"/> Registered Raleigh SCS	E-mail:	Address:	
	Name:		
<input type="checkbox"/> Certified MWBE <input type="checkbox"/> Registered Raleigh SCS	E-mail:	Address:	
	Name:		
<input type="checkbox"/> Certified MWBE <input type="checkbox"/> Registered Raleigh SCS	E-mail:	Address:	
	Name:		
<input type="checkbox"/> Certified MWBE <input type="checkbox"/> Registered Raleigh SCS	E-mail:	Address:	
	Name:		
<input type="checkbox"/> Certified MWBE <input type="checkbox"/> Registered Raleigh SCS	E-mail:	Address:	

Certification must be with NCHUB or the NCDOT-DBE. Proof of Certification may be required upon request by the City.

Total Contract Amount \$ _____

Total MWBE Utilization \$ _____

Percent MWBE Utilization _____ %
(Total MWBE Utilization divided by Total Contract Amount)

APPENDIX E - CERTIFIED SUBCONTRACTOR / SUPPLIER PAYMENT APPLICATION FORM

Contractors must submit this form with each request for payment from the City of Raleigh, including any invoice or request for final payment. Requests for payment are limited to work that has been completed and approved for all subcontractors and suppliers in connection with the Contract. Copy this form as needed. The Contractor on the Prime Contract (i.e., Prime) is responsible for collecting and submitting this Appendix E from all subsequent lower tier contractors.

Section 1: PROJECT INFORMATION

Project Name			Contractor Name		
Total Contract Amount	\$		Pay App #/Contract ID #		
Total MWBE Sub (\$/%)	\$	%	Invoice Amount	\$	
Payment Period	___/___/20___ through ___/___/20___		City Department		
FINAL PAYMENT <input type="checkbox"/> Check only when submitting Final Pay Request.			Project Completion Date		

Section 2: PAYMENTS TO SUBCONTRACTORS

Complete the chart below for all MWBE subcontractors used on the Project/Contract regardless of dollar amount.

Company Name	MWBE Classification	Work Performed	Percentage of Total Contract	Percent of Subcontract Completed	Payment this Period	Cumulative Payments to Date

*MWBE Classifications: American Indian (AI), Asian American (AA), Black/African-American (B), Hispanic (H), Non-Minority Female (NMF), Socially/Economic Disadvantaged (D)

Section 3: PAYMENTS TO SUPPLIERS

All suppliers providing goods under City contracts must be listed on the Sales Tax Statement submitted with each pay request. The City may request, on a case-by-case basis, that the Contractor require certain suppliers to be registered in the Raleigh Supplier Connection System and may withhold payment of any amounts due the Contractor in the event the Contractor fails to comply with such request.

The undersigned certifies the preceding chart is a true and accurate statement of all payments that have been made to subcontractors on this Project/Contract, and that all Suppliers providing goods under this contract have been listed in the Sales Tax Statements submitted to the City in connection with this Payment Appendix E. If no subcontractors or suppliers are listed on the preceding chart or Sales Tax Statements, the undersigned certifies that no subcontractors or suppliers were used in performing the Project/Contract for the payment period indicated. Failure to provide accurate and truthful information is a violation of the City of Raleigh MWBE Policy and may result in the sanctions prescribed therein.

This _____ day of _____ 20____

Signature

Print Name and Title

To be completed by City for FINAL PAYMENT

Total Paid to Contractor	\$	Proposed MWBE Amount	\$	MWBE Commitment:_____%
<input type="checkbox"/> Prime Contractor MWBE				
Total Paid to Subcontractors	\$	Total to MWBE Subcontractors	\$	MWBE Final:_____%

REQUEST TO CHANGE A MWBE SUBCONTRACTOR

Contractors must submit this form for **any request** to change any MWBE subcontractor or supplier in connection with the Contract. The Contractor on the Prime Contract (i.e. prime) is responsible for collecting and submitting this form from all subsequent lower tier contractors.

PROJECT NAME			
PROJECT MANAGER		CONTRACT NUMBER	
PRIME CONTRACTOR		CONTACT NAME	
PHONE NUMBER		E-MAIL ADDRESS	
DATE OF CHANGE		CITY DEPARTMENT	

SECTION 1: PREVIOUS REQUESTS FOR CHANGE

NO PREVIOUS REQUEST FOR THIS PROJECT/CONTRACT.

Complete the chart below for all previous Requests to Change a MWBE Subcontractor.

Date of Request	Subcontractor's Company Name	MWBE Classification	Request Approved: Y/N	Work Performed

MWBE Classifications: American Indian (AI), Asian American (AA), Black/African-American (B), Hispanic (H), Non-Minority Female (NMF), Socially/Economic Disadvantaged (D)

Section 2: CURRENT MWBE SUBCONTRACTOR INFORMATION

CURRENT MWBE SUBCONTRACTOR			
SERVICE PROVIDED			
PERCENT OF TOTAL CONTRACT	_____ %	PERCENT OF SUBCONTRACT COMPLETE	_____ %
TOTAL AMOUNT OF SUBCONTRACT	\$ _____	TOTAL AMOUNT PAID TO DATE	\$ _____

Section 3: PROPOSED ACTION (SELECT ONE)

WORK TO BE SELF-PERFORMED

Check this box **only** if the work previously performed by the above MWBE subcontractor will be performed with your own current work forces, and you normally perform and have the capability to perform all elements of this work on this Project/Contract with your own current work forces.

REPLACE MWBE SUBCONTRACTOR

Section 4: REASON FOR CHANGE (SELECT AT LEAST ONE)

- The listed MWBE, after having had a reasonable opportunity to do so, fails or refuses to execute a written contract.
- The listed MWBE is bankrupt or insolvent.
- The listed MWBE fails or refuses to perform the subcontract or furnish the listed materials.

- The work performed by the listed subcontractor is unsatisfactory according to industry standards and is not in accordance with the plans and specifications.
- The subcontractor is substantially delaying or disrupting the progress of the work.
- Other - explain in detail on company letter head and attach to this Request.

Section 5: NEW SUBCONTRACTOR INFORMATION (IF APPLICABLE)

Complete the information below for the new MWBE subcontractor requested to be changed on the Project/Contract.

Company Name	Contact Person	MWBE Classification	Work to be Performed	Amount of Subcontract	Subcontractor's Percentage of Total Contract

MWBE Classifications: American Indian (AI), Asian American (AA,) Black/African-American (B), Hispanic (H), Non-Minority Female (NMF), Socially/Economic Disadvantaged (D)

If new subcontractor(s) is not MWBE, attach documentation of Good Faith Efforts (Affidavit A).

This the ___ of _____, 20____

_____ Signature _____ Printed Name/Title

TO BE COMPLETED BY CITY

SIGNATURE:

Original Total Contract Amount: \$ _____

Original Total MWBE Participation _____ %

PRINT NAME:

New Total Contract Amount: \$ _____

New Total MWBE Participation _____ %

DATE:

Contract Amount Impact Increase \$ _____
 Decrease \$ _____
 No Change

MWBE Participation Change Increase _____ %
 Decrease _____ %
 No Change

APPROVED

 REJECTED

NOTES:



Minority and Women-owned Business Enterprise Program (MWBE)

Explanation of Affidavit A

A Listing of the Good Faith Effort (GFE)

Company has made a good faith effort to recruit minority businesses in accordance with N.C. Gen. Stat. § 143-128.2 and represents that it has performed the following (**check all that apply; note that a minimum of fifty (50) points must be achieved**):

Examples of ways to satisfy requirements are given for each criterion below:

- ❑ 1. (10 points) Contacted minority businesses that reasonably could have been expected to submit a quote and that were known to the contractor or available on State or local government maintained lists, at least 10 days before the bid date and notified them of the nature and scope of the work to be performed.
 - *Provide a list of potential bidders with proof of acknowledged responses (i.e. quotes)*
 - *Provide confirmation of notification at least 10 days before bid date*
 - *Newspaper/trade ads do not qualify as GFE notification*

- ❑ 2. (10 points) Made the construction plans, specifications and requirements available for review by prospective minority businesses, or provided these documents to them at least 10 days before the bids are due.
 - *Provide confirmation of notification at least 10 days before bid date*
 - *Include in the notice that plan specs are available in office/online (location/link) and at no cost to MWBEs*
 - *Newspaper/trade ads do not qualify as GFE notification*

- ❑ 3. (15 points) Broke down or combined elements of work into economically feasible units to facilitate minority participation.
 - *Provide confirmation of solicitation that include subcontracting opportunities (i.e. itemize or group trades such as flooring/trim or divide one sub does flooring and another sub does trim)*

- ❑ 4. (10 points) Worked with minority trade, community, or contractor organizations identified by the Office of Historically Underutilized Businesses and included in the bid documents that provide assistance in recruitment of minority businesses.
 - *Obtain letter or other documentation from one of these organizations indicating that you are working with them in the recruitment of minority businesses – NCMWBE Coordinators Network, The Institute, NCIEDI or HCAC.*
 - *A list of organizations can be found at www.raleighnc.gov/mwbe*

- ❑ 5. (10 points) Attended pre-bid meetings scheduled by the public owner.
 - **Attendance is recorded (make sure you sign-in)**

- ❑ 6. (20 points) Provided assistance in getting required bonding or insurance or provided alternatives to bonding or insurance for subcontractors.
 - **Include one of the following statements in solicitation to MWBEs as it applies:**
 - **Bonds are not required for this project**
 - **Bidder will assist in procuring bonds or insurance if necessary**

- ❑ 7. (15 points) Negotiated in good faith with interested minority businesses and did not reject them as unqualified without sound reasons based on their capabilities. Any rejection of a minority business based on lack of qualification should have the reasons documented in writing.
 - **“MWBE Solicitation Form” is attached to the Explanation Affidavit A Form**
 - **Provide completed MWBE Solicitation Form to document the following:**
 - **Did not receive low quotes from MWBEs**
 - **Bidder accepted other low quotes from MWBEs**
 - **Written reasons for rejection of any low quotes from MWBEs**

- ❑ 8. (25 points) Provided assistance to an otherwise qualified minority business in need of equipment, loan capital, lines of credit, or joint pay agreements to secure loans, supplies, or letters of credit, including waiving credit that is ordinarily required. Assisted minority businesses in obtaining the same unit pricing with the bidder’s suppliers in order to help minority businesses in establishing credit.
 - **Indicate in solicitation the following are available: equipment, loan capital, lines of credit, or joint pay agreements for qualified MWBEs or any other needs.**
 - **Document recent history of doing joint pay agreements such as “in the recent past, we have done joint pay agreements (lines of credit, waiving of credit, etc.) with the following MWBEs (x company, y company, z company) and intend to offer the same on this project for qualified MWBEs”**
 - **Provide letter from vendor/supplier indicating that they will give the same pricing to MWBEs quoting to you as vendor/supplier gives directly to you**

- ❑ 9. (20 points) Negotiated joint venture and partnership arrangements with minority businesses in order to increase opportunities for minority business participation on a public construction or repair project when possible.
 - **Indicate in solicitation that opportunities to negotiate joint venture and partnership arrangements are available**

- ❑ 10. (20 points) Provided quick pay agreements and policies to enable minority contractors and suppliers to meet cash flow demands.
 - **Indicate in solicitation that quick pay agreements are available for certified MWBEs to include payment terms (i.e., Net 30).**
 - **Document recent history of doing quick pay agreements such as “in the recent past, we have done quick pay agreements with the following MWBE’s (x company, y company, z company) and intend to offer the same on this project for qualified MWBE’s”**

SOLICITATION FORM

Copy this Form as needed to document MWBE contacts.

The Bidder must make the required contacts no less than ten (10) Days before Bid Opening to receive credit for this Good Faith Effort. All contacts must be verifiable with supporting documentation reflecting the methods and content of the solicitation. All documentation must be submitted with this form.

A Bidder must submit this Solicitation Form within the time specified in the City Solicitation Documents. If no time period is specified in the City Solicitation Documents, the Bidder must submit this form within three (3) Business Days after the City requests it.

SECTION 1. PROJECT INFORMATION

Project Name			
Project Number		City Department	
Bidder		Number MWBEs Contacted	

SECTION 2. SOLICITATION INFORMATION
--

If “No” is checked for “Selected” below, the Bidder must document the reasons for rejecting each bid submitted by a MWBE on the Good Faith Negotiation Form.

MWBE FIRM		CONTACT PERSON	
SCOPE OF WORK			
INITIAL CONTACT	DATE: ___/___/20___	METHOD (select all used):	<input type="checkbox"/> Email <input type="checkbox"/> Telephone <input type="checkbox"/> Fax <input type="checkbox"/> In-Person <input type="checkbox"/> Mail
FOLLOW-UP	DATE: ___/___/20___	METHOD (select all used):	<input type="checkbox"/> Email <input type="checkbox"/> Telephone <input type="checkbox"/> Fax <input type="checkbox"/> In-Person <input type="checkbox"/> Mail
RESPONSE	<input type="checkbox"/> No Response	<input type="checkbox"/> Not Bidding	<input type="checkbox"/> Bidding (\$_____) <input type="checkbox"/> Other (Explain)
SELECTED	<input type="checkbox"/> Yes	<input type="checkbox"/> No (Explain)	

MWBE FIRM		CONTACT PERSON	
SCOPE OF WORK			
INITIAL CONTACT	DATE: ___/___/20___	METHOD (select all used):	<input type="checkbox"/> Email <input type="checkbox"/> Telephone <input type="checkbox"/> Fax <input type="checkbox"/> In-Person <input type="checkbox"/> Mail
FOLLOW-UP	DATE: ___/___/20___	METHOD (select all used):	<input type="checkbox"/> Email <input type="checkbox"/> Telephone <input type="checkbox"/> Fax <input type="checkbox"/> In-Person <input type="checkbox"/> Mail
RESPONSE	<input type="checkbox"/> No Response	<input type="checkbox"/> Not Bidding	<input type="checkbox"/> Bidding (\$_____) <input type="checkbox"/> Other (Explain)
SELECTED	<input type="checkbox"/> Yes	<input type="checkbox"/> No (Explain)	

MWBE FIRM		CONTACT PERSON	
SCOPE OF WORK			
INITIAL CONTACT	DATE: ___/___/20___	METHOD (select all used):	<input type="checkbox"/> Email <input type="checkbox"/> Telephone <input type="checkbox"/> Fax <input type="checkbox"/> In-Person <input type="checkbox"/> Mail
FOLLOW-UP	DATE: ___/___/20___	METHOD (select all used):	<input type="checkbox"/> Email <input type="checkbox"/> Telephone <input type="checkbox"/> Fax <input type="checkbox"/> In-Person <input type="checkbox"/> Mail
RESPONSE	<input type="checkbox"/> No Response	<input type="checkbox"/> Not Bidding	<input type="checkbox"/> Bidding (\$_____) <input type="checkbox"/> Other (Explain)
SELECTED	<input type="checkbox"/> Yes	<input type="checkbox"/> No (Explain)	

PERFORMANCE BOND

<p>Contractor</p> <p>Name: _____</p> <p>Address <i>(as registered with Secretary of State, if applicable)</i>: _____</p>	<p>Surety</p> <p>Name: _____</p> <p>Address <i>(as registered with Secretary of State, if applicable)</i>: _____</p>
<p>Owner</p> <p>Name: City of Raleigh</p> <p>Mailing address: 222 W. Hargett Street Raleigh, NC 27601</p>	<p>Contract</p> <p>Description <i>(name and location)</i>: _____</p> <p>Contract Price: _____</p> <p>Effective Date of Contract: _____</p>
<p>Bond</p> <p>Bond Amount: _____</p> <p>Date of Bond: _____ <i>(Date of Bond cannot be earlier than Effective Date of Contract)</i></p> <p>Modifications to this Bond form: <input type="checkbox"/> None <input type="checkbox"/> See Paragraph 16</p>	
<p>Surety and Contractor, intending to be legally bound hereby, subject to the terms set forth in this Performance Bond, do each cause this Performance Bond to be duly executed by an authorized officer, agent, or representative.</p>	
Contractor as Principal	Surety
<p>By: _____ <i>(Full formal name of Contractor)</i></p> <p>_____ <i>(Signature)</i></p> <p>Name: _____ <i>(Printed or typed)</i></p> <p>Title: _____</p> <p>Attest: _____ <i>(Signature)</i></p> <p>Name: _____ <i>(Printed or typed)</i></p> <p>Title: _____</p>	<p>By: _____ <i>(Full formal name of Surety) (corporate seal)</i></p> <p>_____ <i>(Signature)(Attach Power of Attorney)</i></p> <p>Name: _____ <i>(Printed or typed)</i></p> <p>Title: _____</p> <p>Attest: _____ <i>(Signature)</i></p> <p>Name: _____ <i>(Printed or typed)</i></p> <p>Title: _____</p>
<p><i>Notes: (1) Provide supplemental execution by any additional parties, such as joint venturers. (2) Any singular reference to Contractor, Surety, Owner, or other party is considered plural where applicable.</i></p>	

1. The Contractor and Surety, jointly and severally, bind themselves, their heirs, executors, administrators, successors, and assigns to the Owner for the performance of the Construction Contract, which is incorporated herein by reference.
2. If the Contractor satisfactorily performs the Construction Contract, the Surety and the Contractor shall have no obligation under this Bond, except when applicable to participate in a conference as provided in Paragraph 3.
3. If there is no Owner Default under the Construction Contract, the Surety's obligation under this Bond will arise after:
 - 3.1. The Owner first provides notice to the Contractor and the Surety that the Owner is considering declaring a Contractor Default. Such notice may indicate whether the Owner is requesting a conference among the Owner, Contractor, and Surety to discuss the Contractor's performance. If the Owner does not request a conference, the Surety may, within five (5) business days after receipt of the Owner's notice, request such a conference. If the Surety timely requests a conference, the Owner shall attend. Unless the Owner agrees otherwise, any conference requested under this Paragraph 3.1 will be held within ten (10) business days of the Surety's receipt of the Owner's notice. If the Owner, the Contractor, and the Surety agree, the Contractor shall be allowed a reasonable time to perform the Construction Contract, but such an agreement does not waive the Owner's right, if any, subsequently to declare a Contractor Default;
 - 3.2. The Owner declares a Contractor Default, terminates the Construction Contract and notifies the Surety; and
 - 3.3. The Owner has agreed to pay the Balance of the Contract Price in accordance with the terms of the Construction Contract to the Surety or to a contractor selected to perform the Construction Contract.
4. Failure on the part of the Owner to comply with the notice requirement in Paragraph 3.1 does not constitute a failure to comply with a condition precedent to the Surety's obligations, or release the Surety from its obligations, except to the extent the Surety demonstrates actual prejudice.
5. When the Owner has satisfied the conditions of Paragraph 3, the Surety shall promptly and at the Surety's expense take one of the following actions:
 - 5.1. Arrange for the Contractor, with the consent of the Owner, to perform and complete the Construction Contract;
 - 5.2. Undertake to perform and complete the Construction Contract itself, through its agents or independent contractors;
 - 5.3. Obtain bids or negotiated proposals from qualified contractors acceptable to the Owner for a contract for performance and completion of the Construction Contract, arrange for a contract to be prepared for execution by the Owner and a contractor selected with the Owners concurrence, to be secured with performance and payment bonds executed by a qualified surety equivalent to the bonds issued on the Construction Contract, and pay to the Owner the amount of damages as described in Paragraph 7 in excess of the Balance of the Contract Price incurred by the Owner as a result of the Contractor Default; or
 - 5.4. Waive its right to perform and complete, arrange for completion, or obtain a new contractor, and with reasonable promptness under the circumstances:
 - 5.4.1 After investigation, determine the amount for which it may be liable to the Owner and, as soon as practicable after the amount is determined, make payment to the Owner; or
 - 5.4.2 Deny liability in whole or in part and notify the Owner, citing the reasons for denial.

6. If the Surety does not proceed as provided in Paragraph 5 with reasonable promptness, the Surety shall be deemed to be in default on this Bond seven days after receipt of an additional written notice from the Owner to the Surety demanding that the Surety perform its obligations under this Bond, and the Owner shall be entitled to enforce any remedy available to the Owner. If the Surety proceeds as provided in Paragraph 5.4, and the Owner refuses the payment, or the Surety has denied liability, in whole or in part, without further notice, the Owner shall be entitled to enforce any remedy available to the Owner.
7. If the Surety elects to act under Paragraph 5.1, 5.2, or 5.3, then the responsibilities of the Surety to the Owner will not be greater than those of the Contractor under the Construction Contract, and the responsibilities of the Owner to the Surety will not be greater than those of the Owner under the Construction Contract. Subject to the commitment by the Owner to pay the Balance of the Contract Price, the Surety is obligated, without duplication for:
 - 7.1. the responsibilities of the Contractor for correction of defective work and completion of the Construction Contract;
 - 7.2. additional legal, design professional, and delay costs resulting from the Contractor's Default, and resulting from the actions or failure to act of the Surety under Paragraph 5; and
 - 7.3. liquidated damages, or if no liquidated damages are specified in the Construction Contract, actual damages caused by delayed performance or non-performance of the Contractor.
8. If the Surety elects to act under Paragraph 5.1, 5.3, or 5.4, the Surety's liability is limited to the amount of this Bond.
9. The Surety shall not be liable to the Owner or others for obligations of the Contractor that are unrelated to the Construction Contract, and the Balance of the Contract Price will not be reduced or set off on account of any such unrelated obligations. No right of action will accrue on this Bond to any person or entity other than the Owner or its heirs, executors, administrators, successors, and assigns.
10. The Surety hereby waives notice of any change, including changes of time, to the Construction Contract or to related subcontracts, purchase orders, and other obligations.
11. Any proceeding, legal or equitable, under this Bond must be instituted in any court of competent jurisdiction in the location in which the work or part of the work is located and must be instituted within two years after a declaration of Contractor Default or within two years after the Contractor ceased working or within two years after the Surety refuses or fails to perform its obligations under this Bond, whichever occurs first. If the provisions of this paragraph are void or prohibited by law, the minimum periods of limitations available to sureties as a defense in the jurisdiction of the suit will be applicable.
12. Notice to the Surety, the Owner, or the Contractor must be mailed or delivered to the address shown on the page on which their signature appears.
13. When this Bond has been furnished to comply with a statutory or other legal requirement in the location where the construction was to be performed, any provision in this Bond conflicting with said statutory or legal requirement will be deemed deleted therefrom and provisions conforming to such statutory or other legal requirement will be deemed incorporated herein. When so furnished, the intent is that this Bond will be construed as a statutory bond and not as a common law bond.
14. Definitions
 - 14.1. *Balance of the Contract Price*—The total amount payable by the Owner to the Contractor under the Construction Contract after all proper adjustments have been made including allowance for the Contractor for any amounts received or to be received by the Owner in settlement of insurance or other claims for damages to which the Contractor is entitled, reduced by all valid and proper payments made to or on behalf of the Contractor under the Construction Contract.

- 14.2. *Construction Contract*—The agreement between the Owner and Contractor identified on the cover page, including all Contract Documents and changes made to the agreement and the Contract Documents.
 - 14.3. *Contractor Default*—Failure of the Contractor, which has not been remedied or waived, to perform or otherwise to comply with a material term of the Construction Contract.
 - 14.4. *Owner Default*—Failure of the Owner, which has not been remedied or waived, to pay the Contractor as required under the Construction Contract or to perform and complete or comply with the other material terms of the Construction Contract.
 - 14.5. *Contract Documents*—All the documents that comprise the agreement between the Owner and Contractor.
15. If this Bond is issued for an agreement between a contractor and subcontractor, the term Contractor in this Bond will be deemed to be Subcontractor and the term Owner will be deemed to be Contractor.
 16. Modifications to this Bond are as follows: **None**

PAYMENT BOND

<p>Contractor</p> <p>Name: _____</p> <p>Address <i>(as registered w/ Secretary of State, if applicable)</i>: _____</p>	<p>Surety</p> <p>Name: _____</p> <p>Address <i>(as registered w/ Secretary of State, if applicable)</i>: _____</p>
<p>Owner</p> <p>Name: City of Raleigh</p> <p>Mailing address: 222 W. Hargett Street Raleigh, NC 27601</p>	<p>Contract</p> <p>Description <i>(name and location)</i>: _____</p> <p>Contract Price: _____</p> <p>Effective Date of Contract: _____</p>
<p>Bond</p> <p>Bond Amount: _____</p> <p>Date of Bond: _____ <i>(Date of Bond cannot be earlier than Effective Date of Contract)</i></p> <p>Modifications to this Bond form: <input type="checkbox"/> None <input type="checkbox"/> See Paragraph 18</p>	
<p>Surety and Contractor, intending to be legally bound hereby, subject to the terms set forth in this Payment Bond, do each cause this Payment Bond to be duly executed by an authorized officer, agent, or representative.</p>	
Contractor as Principal	Surety
<p>By: _____ <i>(Full formal name of Contractor)</i></p> <p>By: _____ <i>(Full formal name of Surety) (corporate seal)</i></p>	<p>By: _____ <i>(Signature)</i></p> <p>By: _____ <i>(Signature)(Attach Power of Attorney)</i></p>
<p>Name: _____ <i>(Printed or typed)</i></p>	<p>Name: _____ <i>(Printed or typed)</i></p>
<p>Title: _____</p>	<p>Title: _____</p>
<p>Attest: _____ <i>(Signature)</i></p>	<p>Attest: _____ <i>(Signature)</i></p>
<p>Name: _____ <i>(Printed or typed)</i></p>	<p>Name: _____ <i>(Printed or typed)</i></p>
<p>Title: _____</p>	<p>Title: _____</p>
<p><i>Notes: (1) Provide supplemental execution by any additional parties, such as joint venturers. (2) Any singular reference to Contractor, Surety, Owner, or other party is considered plural where applicable.</i></p>	

1. The Contractor and Surety, jointly and severally, bind themselves, their heirs, executors, administrators, successors, and assigns to the Owner to pay for labor, materials, and equipment furnished for use in the performance of the Construction Contract, which is incorporated herein by reference, subject to the following terms.
2. If the Contractor promptly makes payment of all sums due to Claimants, and defends, indemnifies, and holds harmless the Owner from claims, demands, liens, or suits by any person or entity seeking payment for labor, materials, or equipment furnished for use in the performance of the Construction Contract, then the Surety and the Contractor shall have no obligation under this Bond.
3. If there is no Owner Default under the Construction Contract, the Surety's obligation to the Owner under this Bond will arise after the Owner has promptly notified the Contractor and the Surety (at the address described in Paragraph 13) of claims, demands, liens, or suits against the Owner or the Owner's property by any person or entity seeking payment for labor, materials, or equipment furnished for use in the performance of the Construction Contract, and tendered defense of such claims, demands, liens, or suits to the Contractor and the Surety.
4. When the Owner has satisfied the conditions in Paragraph 3, the Surety shall promptly and at the Surety's expense defend, indemnify, and hold harmless the Owner against a duly tendered claim, demand, lien, or suit.
5. The Surety's obligations to a Claimant under this Bond will arise after the following:
 - 5.1. Claimants who do not have a direct contract with the Contractor
 - 5.1.1. have furnished a written notice of non-payment to the Contractor, stating with substantial accuracy the amount claimed and the name of the party to whom the materials were, or equipment was, furnished or supplied or for whom the labor was done or performed, within ninety (90) days after having last performed labor or last furnished materials or equipment included in the Claim; and
 - 5.1.2. have sent a Claim to the Surety (at the address described in Paragraph 13).
 - 5.2. Claimants who are employed by or have a direct contract with the Contractor have sent a Claim to the Surety (at the address described in Paragraph 13).
6. If a notice of non-payment required by Paragraph 5.1.1 is given by the Owner to the Contractor, that shall be sufficient to satisfy a Claimant's obligation to furnish a written notice of non-payment under Paragraph 5.1.1.
7. When a Claimant has satisfied the conditions of Paragraph 5.1 or 5.2, whichever is applicable, the Surety shall promptly and at the Surety's expense take the following actions:
 - 7.1. Send an answer to the Claimant, with a copy to the Owner, within sixty (60) days after receipt of the Claim, stating the amounts that are undisputed and the basis for challenging any amounts that are disputed; and
 - 7.2. Pay or arrange for payment of any undisputed amounts.
 - 7.3. The Surety's failure to discharge its obligations under Paragraph 7.1 or 7.2 will not be deemed to constitute a waiver of defenses the Surety or Contractor may have or acquire as to a Claim, except as to undisputed amounts for which the Surety and Claimant have reached agreement. If, however, the Surety fails to discharge its obligations under Paragraph 7.1 or 7.2, the Surety shall indemnify the Claimant for the reasonable attorney's fees the Claimant incurs thereafter to recover any sums found to be due and owing to the Claimant.

8. The Surety's total obligation will not exceed the amount of this Bond, plus the amount of reasonable attorney's fees provided under Paragraph 7.3, and the amount of this Bond will be credited for any payments made in good faith by the Surety.
9. Amounts owed by the Owner to the Contractor under the Construction Contract will be used for the performance of the Construction Contract and to satisfy claims, if any, under any construction performance bond. By the Contractor furnishing and the Owner accepting this Bond, they agree that all funds earned by the Contractor in the performance of the Construction Contract are dedicated to satisfying obligations of the Contractor and Surety under this Bond, subject to the Owner's priority to use the funds for the completion of the work.
10. The Surety shall not be liable to the Owner, Claimants, or others for obligations of the Contractor that are unrelated to the Construction Contract. The Owner shall not be liable for the payment of any costs or expenses of any Claimant under this Bond, and shall have under this Bond no obligation to make payments to or give notice on behalf of Claimants, or otherwise have any obligations to Claimants under this Bond.
11. The Surety hereby waives notice of any change, including changes of time, to the Construction Contract or to related subcontracts, purchase orders, and other obligations.
12. No suit or action will be commenced by a Claimant under this Bond other than in a court of competent jurisdiction in the state in which the project that is the subject of the Construction Contract is located or after the expiration of one year from the date (1) on which the Claimant sent a Claim to the Surety pursuant to Paragraph 5.1.2 or 5.2, or (2) on which the last labor or service was performed by anyone or the last materials or equipment were furnished by anyone under the Construction Contract, whichever of (1) or (2) first occurs. If the provisions of this paragraph are void or prohibited by law, the minimum period of limitation available to sureties as a defense in the jurisdiction of the suit will be applicable.
13. Notice and Claims to the Surety, the Owner, or the Contractor must be mailed or delivered to the address shown on the page on which their signature appears. Actual receipt of notice or Claims, however accomplished, will be sufficient compliance as of the date received.
14. When this Bond has been furnished to comply with a statutory or other legal requirement in the location where the construction was to be performed, any provision in this Bond conflicting with said statutory or legal requirement will be deemed deleted here from and provisions conforming to such statutory or other legal requirement will be deemed incorporated herein. When so furnished, the intent is that this Bond will be construed as a statutory bond and not as a common law bond.
15. Upon requests by any person or entity appearing to be a potential beneficiary of this Bond, the Contractor and Owner shall promptly furnish a copy of this Bond or shall permit a copy to be made.
16. Definitions
 - 16.1. *Claim*—A written statement by the Claimant including at a minimum:
 - 16.1.1. The name of the Claimant;
 - 16.1.2. The name of the person for whom the labor was done, or materials or equipment furnished;
 - 16.1.3. A copy of the agreement or purchase order pursuant to which labor, materials, or equipment was furnished for use in the performance of the Construction Contract;
 - 16.1.4. A brief description of the labor, materials, or equipment furnished;
 - 16.1.5. The date on which the Claimant last performed labor or last furnished materials or equipment for use in the performance of the Construction Contract;

- 16.1.6. The total amount earned by the Claimant for labor, materials, or equipment furnished as of the date of the Claim;
 - 16.1.7. The total amount of previous payments received by the Claimant; and
 - 16.1.8. The total amount due and unpaid to the Claimant for labor, materials, or equipment furnished as of the date of the Claim.
- 16.2. *Claimant*—An individual or entity having a direct contract with the Contractor or with a subcontractor of the Contractor to furnish labor, materials, or equipment for use in the performance of the Construction Contract. The term Claimant also includes any individual or entity that has rightfully asserted a claim under an applicable mechanic’s lien or similar statute against the real property upon which the Project is located. The intent of this Bond is to include without limitation in the terms of “labor, materials, or equipment” that part of the water, gas, power, light, heat, oil, gasoline, telephone service, or rental equipment used in the Construction Contract, architectural and engineering services required for performance of the work of the Contractor and the Contractor’s subcontractors, and all other items for which a mechanic’s lien may be asserted in the jurisdiction where the labor, materials, or equipment were furnished.
 - 16.3. *Construction Contract*—The agreement between the Owner and Contractor identified on the cover page, including all Contract Documents and all changes made to the agreement and the Contract Documents.
 - 16.4. *Owner Default*—Failure of the Owner, which has not been remedied or waived, to pay the Contractor as required under the Construction Contract or to perform and complete or comply with the other material terms of the Construction Contract.
 - 16.5. *Contract Documents*—All the documents that comprise the agreement between the Owner and Contractor.
17. If this Bond is issued for an agreement between a contractor and subcontractor, the term Contractor in this Bond will be deemed to be Subcontractor and the term Owner will be deemed to be Contractor.
 18. Modifications to this Bond are as follows: **None**

**PROCEDURE FOR REPORTING NORTH CAROLINA SALES TAX
EXPENDITURES ON CITY OF RALEIGH CONTRACTS**

(for projects with reimbursable sales tax excluded from Bid)

1. The following procedure in handling the North Carolina Sales Tax is applicable to this project. Contractors shall comply fully with the requirements outlined hereinafter, in order that the owner may recover the amount of the tax permitted under the law. For the purposes of this section, "Sales Taxes" shall mean sales and use taxes paid to the State of North Carolina or to local governments in North Carolina.
 - (a) Reimbursable Sales Taxes are to be excluded from the bid price for this project.
 - (b) The City is entitled to refunds from the State of North Carolina for these reimbursable sales taxes. The Contractor that performs work under this contract is allowed to obtain a reimbursement from the City for those Sales Taxes for which the State will grant a refund to the City. The City will reimburse the Contractor, and the City later obtains a refund from the State.
 - (c) It shall be the general contractor's responsibility to furnish the City documentary evidence showing the materials used and sales tax paid by the general contractor and each of his subcontractors. Any county sales tax included in the contractor's statements must be shown separately from the state sales tax. If more than one county is shown, each county shall be listed separately.
 - (d) The documentary evidence shall be the attached Reimbursable Sales and Use Tax Statement. This evidence shall consist of a certified statement, by the general contractor and each of his subcontractors individually, showing total purchases of materials from each separate vendor and total sales taxes by each county paid each vendor. The certified statement must show the invoice number (s) covered and inclusive dates of such invoices. State sales tax shall be listed separately from county sales tax. If more than one county is shown, each county shall be listed separately. The invoices shall be provided to substantiate the information on the statement.
 - (e) Materials used from general contractor's or subcontractor's warehouse stock shall be shown in a certified statement at warehouse stock prices.
 - (f) The general contractor shall not be required to certify the subcontractor's statements. However, the subcontractor may submit for reimbursement by certifying a Reimbursable Sales and Use Tax Statement, submitting it to the general contractor for the general contractor to submit with the pay application for the properties listed on that form. The City will make the reimbursement payable to the Contractor.
 - (g) The documentary evidence to be furnished to owners eligible for Reimbursable Sales Tax refunds covers sales and/or use taxes paid on building materials used by general contractors and subcontractors in the performance of contracts with churches, orphanages, hospitals not for profit, educational institutions not operated for profit and other charitable or religious institutions or organizations not operated for profit and incorporated cities, towns and counties in this State. The documentary evidence is to be submitted to the above-named institutions, organizations and

governmental units to be included in claims for refunds to be prepared and submitted by them to obtain refunds provided by G.S. 105-164.14 and is to include the purchase of building materials, supplies, fixtures and equipment which become a part of or annexed to buildings or structures being erected, altered or repaired under contracts with such institutions, organizations or governmental units.

- (h) The Contractor may seek reimbursement separately from, but at the same time as, the application for payment is made for the properties that were taxed. The Contractor shall not file for reimbursement for Sales Taxes before the Contractor has the right to file an application for payment for the properties that were taxed.
2. If the State refuses to refund any such Sales Tax to the City, or if after a refund is made, the City is told to return a refund to the State, the Contractor shall upon demand repay the City for the amount of the failed refunds.
 3. The contractor or contractors to whom an award is made on this project will be required to follow the procedure outlined above.
 4. The contractor is advised that all requests for payment, partial or final, for work completed under this contract must include a sales tax report submitted in accordance with the procedures outlined above.

North Carolina Reimbursable Sales and Use Tax Statement by Subcontractor

(Paid During This Estimate Period)

Project _____ Location _____

County _____

Estimate No. _____

Name of Subcontractor _____ Period Ending _____

Date	Vendor	Type of Property	Invoice Number	Invoice Amount	State Tax	County Tax	Total Tax	County
TOTALS								

The undersigned individual certifies (1) that he or she is an employee or principal of the Subcontractor that is submitting this form with the Contractor so that the Contractor may request reimbursement for N.C. State and local sales and use taxes that the Subcontractor has paid, (2) that the above listed vendors were paid sales tax upon purchases of building materials during the period covered by the construction estimate, and the property upon which such taxes were paid with or will be used in the performance of this contract,(3) that no tax on purchases or rentals of tools and/or equipment is included in the above list, (4) that all of the material above became a part of or is annexed to the building or structure being erected, altered or repaired, and (5) that all of the information on this form, and any additional pages added to this page, if any, is true and accurate.

_____ County, North Carolina
 Signed and sworn to (or affirmed) before this day by _____

 (name of principal)
 (signature of principal)

Date: _____

 Notary Public's Signature

(Notary's printed or typed name, Notary Public) (Official Seal)

My commission expires:

FINAL PAYMENT AFFIDAVIT
(REQUIRED AT TIME OF FINAL PAYMENT)

Bridge Repair & Preservation

City of Raleigh Project No. 274-TM-3-26R State of North Carolina
County of Wake

In the State of North Carolina , County of _____, being duly sworn, deposes and says that they are _____ of _____ and that they have full and official knowledge of all and every debt and obligation for labor and materials which have entered into and become a part of the public facilities constructed under City of Raleigh Project Number 274-TM-3-26; and, acting in their official capacity, and for the specific purpose of obtaining the funds due on this final estimate, they further depose and say that all debts or obligations for such labor and materials have been fully and completely paid and discharged in good and lawful money of the United States of America or by evidence of exchange or trade acceptances endorsed and guaranteed by a solvent National or State bank, and that there are no suits for damages against the Contractor, pending, prospective or otherwise, in consequence of their operations on the said project except as follows:

In witness whereof, they have set their hand and seal,

I, _____, a notary public of the County and State aforesaid, hereby certify that _____ personally known to me to be the affiant in the foregoing affidavit, personally appeared before me this day and having been by me duly sworn, deposes and says that the facts set forth in the above affidavit are true and correct.

Witness my hand and official seal this the _____ day of _____, 2026.

Notary Public _____

My Commission Expires: _____

(SEAL)

ITEMIZED BID

BIDDER NAME:

PROJECT #: **274-TM-3-26R**

PROJECT NAME: **City of Repair Bridge Repair & Preservation 2026**

SCHEDULE OF PRICES

Item	ITEM DESCRIPTION	Quantity	Unit	Unit Price	Amount
1	Mobilization	1	LS		
2	Select Materials	10	TON		
	<u>Structure No. 910342 - Atlantic Ave.</u>				
3	Traffic Control	1	LS		
4	Shotcrete Repair (Superstructure)	500	SF		
5	Shotcrete Repair (Substructure)	15	SF		
6	Concrete Repairs (Epoxy Coating)	60	SF		
7	Railing Repair	1	LS		
	<u>Structure No. 910346 - Brooks Ave.</u>				
8	Traffic Control	1	LS		
9	Shotcrete Repair (Superstructure)	20	SF		
10	Concrete Sidewalk	3	SY		
11	Rip Rap Class B	12	TONS		
12	Utility Repair	1	LS		
13	Flowable Fill	1	CY		
	<u>Structure No. 910661 - Stony Brook Dr.</u>				
	Traffic Control	1	LS		
	Shotcrete Repair (Cord Slabs)	175	SF		
	Shotcrete Repair (Substructure)	30	SF		
	Drift and Debris Removal	1	LS		
	<u>Structure No. 911085 - South State St.</u>				
14	Traffic Control	1	LS		
15	Shotcrete Repair (Superstructure)	35	SF		
	<u>Structure No. 911346 - New Falls of Neuse</u>				
16	Traffic Control	1	LS		
17	Select Materials	75	TON		
18	Rip Rap Class 2	103	TONS		
19	Geotextile Fabric	100	SY		
20	Shotcrete Repair (Superstructure)	5	SF		
21	Asphalt Plug Joint @5"	132	LF		
	<u>Structure No. 911347 - New Falls of Neuse</u>				
22	Traffic Control	1	LS		
23	Drift and Debris Removal	1	LS		
24	Select Materials	135	TON		
25	Rip Rap Class 2	150	TONS		
26	Geotextile Fabric	135	SY		
27	Shotcrete Repair (Superstructure)	5	SF		
28	Asphalt Plug Joint @5"	132	LF		
29	Utility Repair	1	LS		
	<u>Structure No. 911351 - Corporation Pkwy.</u>				
30	Traffic Control	1	LS		

Item	ITEM DESCRIPTION	Quantity	Unit	Unit Price	Amount
31	Shotcrete Repair (Superstructure)	816	SF		
32	Drift and Debris Removal	1	LS		
	<u>Structure No. 911453 - Angel Falls Rd.</u>				
33	Traffic Control	1	LS		
34	Cleaning and Painting Existing Steel for Culvert #911453 (Approximately 600 SQ FT)	1	LS		
35	Painting Containment for Culvert #911453	1	LS		
36	Pollution Control	1	LS		
37	Drift and Debris Removal	1	LS		
	<u>Structure No. 911456 - Angel Falls Rd.</u>				
38	Traffic Control	1	LS		
39	Shotcrete Repairs (Substructure)	8	SF		
40	Cleaning and Painting Existing Steel for Culvert #911456 (Approximately 560 SQ FT)	1	LS		
41	Painting Containment for Culvert #911456	1	LS		
42	Pollution Control	1	LS		
43	Drift and Debris Removal	1	LS		
44	Asphalt Crack Sealing	30	LB		
	<u>Structure No. 911459 - Sellona St.</u>				
45	Traffic Control	1	LS		
46	Rip Rap Class B	48	TONS		
47	Drift and Debris Removal	1	LS		
48	Milling Asphalt Pavement, 2" Depth	240	SY		
49	Asphalt Concrete Surface Course	30	Tons		
50	Thermoplastic Pavement Marking Lines, 4", 90 mils	250	LF		
				Subtotal	
				15% Contingency	
				Total	

GENERAL CONDITIONS

1. Definitions

- A. The Contract documents shall consist of the Contract, the accepted Proposal, the General Conditions of the Contract, and the attached appendix, including all modifications thereof incorporated in the documents before their execution.
- B. Whenever the term "Contractor" is used, it shall be understood as referring to the General Contractor, subcontractor, and all other contractors or their duly authorized agent to whom the work here described is awarded by Contract.
- C. Whenever the term "Replace" or "Replacing" is used, it shall be understood to mean all work associated with the Contract, including but not limited to utility adjustments, erosion protection, tree root mitigation, and concrete pouring.
- D. Whenever the term "Transportation Director" is used, it is understood to mean the Transportation Director of Raleigh, North Carolina, his assistant, or duly authorized agent. The Transportation Director or his authorized agent shall make all necessary explanations as to the meaning and intent of the Specifications, Plans, Special Provisions, or Contract and may correct any errors or omissions in same which is necessary for the proper fulfillment of its intentions. The term "Transportation Director" or his authorized agent shall be synonymous or equivalent with the term "Engineer" and shall have full authority over the work as specified in Section 105-1 of the "North Carolina Department of Transportation Standard Specifications for Roads and Structures", latest edition.
- E. Whenever the term "City" is used, it is to mean the City of Raleigh, North Carolina.
- F. The term "Work" of the Contractor or subcontractor includes labor or materials, or both, equipment, transportation, or other facilities necessary to complete the Contract.
- G. The "North Carolina Department of Transportation Standard Specifications for Roads and Structures", latest edition shall be considered a part of these specifications and shall be enforceable in toto.
- H. The "North Carolina Department of Transportation Policies Procedures", for 2002 accommodating utilities on highway right-of-way shall be considered a part of these specifications in instances to which they are referred.
- I. The terms "Supplemental Agreement" and City Change Order" shall be understood to be synonymous.

2. Bidder's Disqualification

- A. That the City Manager may disqualify bidders from participation in bidding and award of Contracts for city construction projects based on the following conditions existing simultaneously:

- i. The dollar value of the work completed is less than the dollar value of the work which should have been completed on the basis of the contractor's approved progress schedule by more than twenty percent of the current Contract amount. The dollar amount of the work completed will be the total estimate to date shown in the latest partial pay estimate. The current Contract amount will be the Contract estimate plus accumulated overruns and less accumulated underruns shown in the latest partial pay estimate.
 - ii. The percentage of the work completed is less than the percentage of Contract time elapsed on the work by more than twenty percent. The percentage of work completed will be the dollar value of the work complete as defined above divided by the current Contract amount as defined above. The percentage of Contract time elapsed will be the number of calendar days elapsed as shown in the latest partial pay estimate divided by the total Contract time in calendar days.
 - iii. The City Manager shall not include any late days which are caused by the City in any of his calculations directed at determining bid status.
- B. Any contractor who wishes to contest the decision of the City Manager declaring ineligibility may appeal to the City Council by delivering a notice of appeal to the City Clerk no later than ten days after receipt of the City Manager's decision. The notice of appeal shall clearly set out the reasons why the Contractor believes that the terms of this Resolution have been inappropriately applied or the equitable arguments for not applying this Resolution's terms. When considering an appeal the City Council shall consider, among other things, the report of the City Manager, the notice of appeal, and the Contractor's current status on any other current City Contracts and its performance on any other Contracts to which the Contractor and the City have been parties to within the two calendar years immediately preceding the filing of the notice of appeal.
- C. Bidders so disqualified shall remain disqualified for any period in which they are still in conflict with the schedule provisions of this article.

3. Intent of Documents

The intention of the documents is to include all labor and materials, equipment and transportation necessary for the proper execution of the work. It is not intended, however, that materials or work not covered by or properly inferable from any heading, branch, class or trade of the Specifications shall be supplied unless distinctly so noted on the drawings. Materials or work described in words which so applied have a well-known technical or trade meaning shall be held to refer to such recognized standards.

4. Detail Drawings and Instructions

The Transportation Director shall furnish with reasonable promptness, additional instructions by means of drawings or otherwise, necessary for the proper execution of the work. All such drawings and instructions shall be consistent with the Contract documents, true developments thereof, and reasonable inferable therefrom.

The instructions and appendix have been provided with the solicitation on the North Carolina State Interactive Procurement System. If you need assistance contact Dan Callahan at 919-996-2182.

5. Progress Schedule

The Contractor shall submit for approval by the Transportation Director prior to the pre-construction conference, a carefully prepared progress schedule, showing the proposed dates of starting and completing each of the various operations of the work. Additionally, a progress schedule which specifically addresses the completion of sidewalks to be replaced shall be submitted. This schedule shall reflect a minimum of 20% of the total work list to be completed in the first full month of the Contract. This schedule can be combined with the above mentioned schedule or separate. This schedule of completed streets and tons will be utilized on a monthly basis for assessment based on the Contractor's progress in comparison with the approved progress schedule. If applicable, liquidated damages will be deducted on a monthly basis based on the approved project schedule. The progress schedule shall be in graphic form and if required, in accordance with the form supplied by the City.

6. Contractor's Understanding

It is understood and agreed that the Contractor has, by careful examination satisfied himself as to the nature and location of the work, the conformation of the ground, the character, quality and quantity of materials to be encountered, the character of equipment and facilities needed preliminary to and during the prosecution of the work, the general and local conditions, and all other matters which can in any way affect the work under this Contract. No verbal agreement or conversation with any officer, agent or employee of the City, either before or after the execution of the Contract shall affect or modify any terms or obligations herein contained.

7. Superintendence by Contractor

Except where the Contractor is an individual and gives his personal superintendence to the work, the Contractor shall provide a competent superintendent, satisfactory to the City of Raleigh on the work at all times during working hours with full authority to act for him. The Contractor shall also provide an adequate staff for the proper coordination and prosecution of the work.

In the event that subcontractors are used to supplement the prime contractor's forces, the prime contractor shall superintend the subcontractor and shall have his staff present at all work sites involving the subcontractor's forces.

8. Materials, Appliances and Employees

Unless otherwise specified, the Contractor shall provide and pay for all materials, labor, water, tools, equipment, light, power, transportation and other facilities necessary for the execution and completion of the work.

Unless otherwise specified, all materials shall be new and both workmanship and materials shall be of good quality. The Contractor shall, if required, furnish satisfactory evidence as to the kind and quality of materials.

The Contractor shall at all times enforce strict discipline and good order among his employees and shall not employ on the work any unfit person or anyone not skilled in the work assigned to him.

9. Technical Specifications and Drawings

Anything mentioned in the Technical Specifications and not shown on the Drawings or shown on the Drawings and not mentioned in the Technical Specifications shall be of like effect as if shown on or mentioned in both. In case of difference between Drawings and Technical Specifications, the Technical

Specifications shall govern. In case of any discrepancy in Drawings, or Technical Specifications, the matter shall be immediately submitted to the City of Raleigh without whose decision, said discrepancy shall not be adjusted by the Contractor, save only at his own risk and expense.

10. Royalties and Patents

The Contractor shall pay all royalties and patent fees. He shall defend all suits or claims for infringement of any patent rights and shall save the City harmless from loss on account thereof, except that the city shall be responsible for such loss when a particular process or the product of a particular manufacturer or manufacturers is specified, but if the Contractor has information that the process or article specified is an infringement of a patent, he shall be responsible for such loss unless he promptly gives such information to the Transportation Director.

11. Permits

Permits and licenses of a temporary nature necessary for the prosecution of the work shall be secured and paid for by the Contractor unless otherwise stipulated.

Permits, licenses and easements for permanent structures or permanent changes in existing facilities shall be secured and paid for by the City unless otherwise stipulated.

12. Protection of Work and Property

The Contractor shall continuously maintain adequate protection of all his work from damage and shall protect the City's and private property from injury or loss arising in connection with this Contract. He shall make good any such damages, injury or loss, except such as may directly be due to errors in the Contract documents or caused by agents or employees of the City.

13. Cooperation with Utility Owners

Prior to the beginning of construction, the City will notify all utility owners known to have facilities affected by the construction of the project. The Contractor shall coordinate the schedule with the utility owners for the necessary adjustments of all affected public or private utility facilities. The utility adjustments may be made either before or after the beginning of construction of the project. The adjustments will be made by the utility owner or his representative or by the Contractor when such adjustments are part of the work covered by his Contract.

The Contractor shall use special care in working around and near all existing utilities that are encountered during construction, protecting them where necessary so that they will give uninterrupted service. The Contractor shall call the agency concerned for location of all utilities and shall be responsible for any damage to existing utilities and structures resulting from his work around these utilities or structures.

The Contractor shall cooperate with the utility owner, and/or the owner's representative in the adjustment or placement of utility facilities when such adjustment or placement is made necessary by the construction of the project or has been authorized by the City.

In the event that utility services are interrupted by the Contractor, the Contractor shall promptly notify the owners and shall cooperate with the owners and/or the owner's representative in the restoration of service in the shortest time possible.

Existing fire hydrants shall be kept accessible to fire department personnel at all times.

Prior to submitting his bid, the Contractor shall make his own determination as to the nature and extent of the utility facilities, including proposed adjustments, new facilities, or temporary work to be performed by the utility owner or his representative; and as to whether or not any utility work is planned by the owner in conjunction with project construction. The Contractor shall consider in his bid all the permanent and temporary utility facilities in their present or relocated positions, whether or not specifically shown on the plans or covered in the project special provisions. It will be the Contractor's responsibility to anticipate any additional costs to him resulting from such utility work and to reflect these costs in his bid for the various items in the Contract.

Where changes to utility facilities are to be made solely for the convenience of the Contractor, it shall be the Contractor's responsibility to arrange for such changes and the Contractor shall bear all costs of such changes.

14. Inspection of Work

The Transportation Director and his representatives shall at all times have access to the work wherever it is in preparation or progress and the Contractor shall provide facilities for such access and for inspection.

If the specifications, the Transportation Director's instructions, laws, or ordinances or any public authority require any work to be specially tested or approved, the Contractor shall give the Transportation Director timely notice of its readiness for inspection. Inspections by the Transportation Director shall be promptly made, and where practicable at the source of supply. If any work should be covered up without approval or consent of the Transportation Director, it must, if required by the Transportation Director, be uncovered for examination at the Contractor's expense.

The presence of the Engineer or Transportation Director or inspector at the work site shall in no way lessen the Contractor's responsibility for conformity with the contract. Should the Engineer, Transportation Director or Inspector, at any time before final acceptance or during the contractual warranty period, fail to point out or reject materials or work that does not conform to the contract, whether from lack of discovery or for any other reason, it shall in no way prevent later rejection or corrections to the unsatisfactory materials or work when discovered. The contractor shall have no claim for losses suffered due to any necessary removals or repairs resulting from the unsatisfactory work.

15. Changes in Work

The City of Raleigh Transportation Department, without invalidating the Contract, may direct additional work, extra work or make changes by altering, adding or deducting from the work, the Contract sum being adjusted accordingly. In case the method of construction or character of any part of the work is not covered by the plans, specifications, or contract documents, these provisions shall apply.

The Contractor shall perform all work in accordance with the plans, specifications, standard drawings, and contract documents or that may be modified by written orders and shall do such additional, extra, and incidental work as may be considered necessary to complete the work to the full intent of the plans, specifications and contract provisions. Unless otherwise provided in the contract, the Contractor shall furnish all implements, machinery, tools, materials, supplies, transportation and labor necessary for the prosecution and completion of the work.

When it is necessary to make amendments to the contract to satisfactorily complete the proposed construction or to provide authorized time extensions, the Transportation Director or his agent shall have the authority to enter into a City Change Order (CCO) covering such amendments.

City Change Orders (CCOs) shall become a part of the contract when executed by the Transportation Director or his agent and an authorized representative of the Contractor.

A. Additional Work

Additional Work or alterations of the plans or details of construction shall be governed by NCDOT Specifications for Roads and Structures (Latest Edition) - Section 104-3.

B. Overruns and Underruns in Contract Quantities

Overruns and Underruns in contract quantities shall be governed by NCDOT Specifications for Roads and Structures (Latest Edition) - Section 104-5.

C. Eliminated Contract Items

Eliminated Contract Items shall be governed by NCDOT Specifications for Roads and Structures (Latest Edition) - Section 104-6.

D. Extra Work

Extra Work Items shall be governed by NCDOT Specifications for Roads and Structures (Latest Edition) - Section 104-7.

E. Compensation and Record Keeping

Compensation and Record Keeping for items of work in this section shall be governed by the NCDOT Specifications for Roads and Structures (Latest Edition) 4 Section 104-8. The following items shall be governed by section 104-8:

- i. Compensation for Additional Work or Extra work.
- ii. Claims for additional compensation.
- iii. Claims for additional compensation for suspension of work or alleged suspension of work.

Final Determination will be made by the Transportation Director on all claims for additional compensation before payment of the final project invoice.

F. Claims for Time Extension

All claims for time extension shall be governed by the NCDOT Specifications for Roads and Structures (Latest Edition) - Section 108-10.

The value of any such extra work or change shall be determined by the unit prices named in the Contract, up to but not exceeding 25% of the original Contract total price.

For extra work which exceeds 25% of the original Contract total, the value of any such extra work or change shall be determined in one or more of the following ways:

- i. By estimate and acceptance of a lump sum.

- ii. By unit prices named in the Contract or subsequently agreed upon.
- iii. By cost and percentage or by cost and a fixed fee.

16. Conformity with Specifications

All work performed and all materials furnished shall be in reasonably close conformity with the lines, grades, cross sections, dimensions, and material requirements, including tolerances, shown on the appendix, or indicated in the specifications.

In the event the Transportation Director finds the materials or the finished product in which the materials are used not within reasonably close conformity with the specifications, but that reasonably acceptable work has been produced, he will then make a determination if the work is to be accepted and remain in place. If the Transportation Director agrees that the work is to be accepted, he will have the authority to make such adjustment in Contract price as he deems warranted based upon sound engineering judgment and the final estimate will be paid accordingly.

In the event the Transportation Director finds the materials or the finished product in which the materials are used or the work performed are not in reasonably close conformity with the plans and specifications and have resulted in an inferior or unsatisfactory product, the work or materials shall be removed and replaced or otherwise corrected by the Contractor at no cost to the City.

17. Liquidated Damages and Delays

A. Liquidated Damages

If the work cannot be completed within the time stipulated in the Contract, including any extensions of time for excusable delays as herein provided, the Contractor shall pay to the City of Raleigh, a fixed and agreed amount, as liquidated damages for each calendar day of delay, until the work is completed, the amount as set forth in the Contract and the Contractor and his sureties shall be liable to the City of Raleigh for the amount thereof. Liquidated damages will not be waived during completion of the final project punchlist, unless the contract time has been extended as allowed by the contract provisions.

B. Excusable Delays

The right of the Contractor to proceed shall not be terminated nor shall the Contractor be charged with liquidated damages for any delays in the completion of the work due to:

- i. Any act or omission of the City outside the scope of the Contract, including extra work; acts of God; unusually severe and abnormal weather conditions; acts of any other contractor in the performance of work for the City; or other conditions, events, or circumstances beyond the control and without the fault or negligence of the Contractor, which the Contractor could not have reasonably anticipated; or
- ii. Any delay of any Subcontractor occasioned by any of the causes specified in subparagraph (i) above.
 - a. Provided, however, the Contractor shall provide written notice to the Transportation Director within ten (10) days from the occurrence,

condition, event, or other cause which is claimed to have delayed the completion of the work. Such notice shall state what effect, if any, such occurrence, condition, event, or other cause is claimed to have upon the time for completing the Contract work, and shall state in what respects, if any, the Contract completion deadline should be revised, and the reasons therefore. No claim by the Contractor for an extension of time for completion shall be considered unless notice of such delay claim is given the City in accordance with the provisions of this subparagraph.

C. No Damages for Delays

The City shall not be obligated or liable to the Contractor for, and the Contractor hereby expressly waives any claims against the City for, any damages, costs, or expenses of any nature occasioned by delays, work disruptions or interference, changes in work sequence, work suspension or rescheduling arising from any act or omission of the City outside the scope of the Contract, acts of God, unusually severe and abnormal weather conditions, or other causes beyond the Contractor's control, it being understood and agreed that the Contractor's sole and exclusive remedy in the event of his inability to achieve completion by the Contract deadline due to claimed delays shall be an extension of the Contract schedule, but only if a claim for such extension is properly made in accordance with the provisions of subparagraph (B) above.

18. Opening Sections of Project to Traffic

The City of Raleigh, at its election, may give notice to the Contractor and place in use those sections of the improvements which have been completed, inspected and can be accepted as complying with the technical specifications; and if, in its opinion, each such section is reasonably safe, fit, and convenient for the use and accommodations for which it was intended. On such sections which are open, the Contractor shall conduct the remainder of his operations to cause the least obstruction to traffic. The Contractor shall not be relieved of his liability or responsibility, shall not receive any additional compensation due to the added cost of the work, nor shall he receive any extension of the completion date, by reason of such openings.

The Contractor shall not be responsible for any maintenance cost due directly to the use of such sections. The period of guarantee stipulated in Section 53 – Guarantee of Work, shall not begin to run until the date "of release of final inspection punch list items" for all work which the Contractor is required to construct under this Contract.

19. City's Right to Do Work

If the Contractor should neglect to prosecute the work promptly or fail to perform any provisions of the Contract, the City, after 24 hours written notice to the Contractor, may without prejudice to any other remedy he may have, make good such deficiencies and may deduct the cost thereof from the payment then or thereafter due the Contractor.

20. Correction of Work Before Final Payment

Before issuing final payment, the Contractor shall promptly remove from the premises all materials condemned by the Transportation Director as failing to conform with the Contract, whether incorporated in the work or not, and the Contractor shall promptly replace and reexecute his own work in accordance with the Contract and without expense to the City and shall bear the expense of making good all work of other Contractors destroyed or damaged by such removal or replacement.

21. Final Inspection, Clean Up and Project Final Acceptance

A. Final Inspection

- i. When the improvements contained in this Contract are completed, the Contractor shall notify the Transportation Director or designees in writing that the work will be ready for final inspection on a definite date which shall be stated in the notice. The notice shall be given at least ten (10) days prior to the date stated for final inspection and bear the signed concurrence of the representative of the Transportation Director having charge of the inspection. If the Transportation Director determines that the status of the improvements are accurately represented, the Transportation Director will make the arrangements necessary to have the final inspection on the date stated in the notice, or soon thereafter as is practicable. The Final Inspection Team will include the Transportation Director's representatives and the Contractor. The Final Inspection Team may also include representatives of each department of the City of Raleigh as well as a representative of the North Carolina Department of Transportation.
- ii. The Final Inspection Team, on the date agreed upon above, shall make a thorough visual inspection to ensure that the project is satisfactorily completed according to the plans and specifications of the Contract and that all clean-up work is complete.
- iii. The Final Inspection Team, following the final inspection, shall prepare a written list of the deficient items and clean-up work that needs to be corrected before the issuance of the Final Acceptance Document. The list shall include a reasonable period of time, agreed upon with the Contractor, allowing for the completion of the deficient items and clean-up work. A copy of the list shall be mailed to the Contractor.

B. Clean Up Work

Clean up work shall include removal of trash, stone, concrete debris and boards in the medians and right of ways. It shall also include removal of all signage and washing of streets and sidewalks as needed.

C. Project Final Acceptance

The Contractor, after finishing all clean-up work and correction of all deficient items, shall notify the appropriate party on the Inspection Team to make a final inspection of the project. If the Final Inspection Team, during its inspection finds that the deficient items and clean-up work have been satisfactorily completed according to the terms of this Article and the

contract specifications, then the Final Inspection Team recommends to the Transportation Director 's Representative to issue the Final Acceptance Document.

22. Payments to Contractor and Retainage

A. Partial Payments

- i. Partial payment will be based upon progress estimates prepared by the Transportation Director once each month on the date established by the Transportation Director.
- ii. Monthly or partial payments made by the City of Raleigh to the Contractor are monies advanced for the purpose of assisting the Contractor to expedite the work of construction. The Contractor shall be responsible for the care and protection of all materials and work upon which payments have been made until final acceptance of such work and materials by the City of Raleigh. Such payments shall not constitute a waiver of the right of the City of Raleigh to require the fulfillment of all terms of the contract and the delivery of all improvements embraced in this contract complete and satisfactory to the City of Raleigh in all details.

B. Retainage

- i. Retainage will be deducted in accordance with Section 6 of the Contract documents.

C. Final Payment

- i. After final inspection and acceptance by the City of Raleigh and Transportation Director of all work under the contract, the Contractor shall prepare his requisition for final payment which shall be the sum of the Bid unit Prices multiplied by the quantities actually issued or this sum adjusted by approved change orders less prior payments. Final payment request must be accompanied by the Final Payment Affidavit.
- ii. The City of Raleigh before paying the final estimate may require the Contractor to furnish releases or receipts from all subcontractors having performed any work and all persons having supplied materials, equipment and services to the Contractor, if the City of Raleigh deems the same necessary in order to protect its interest. The City of Raleigh, however, may, if it deems such action advisable, make payment in part or in full to the Contractor without requiring the furnishing of such releases or receipts and any payments so made shall in no way impair the obligations of any surety or sureties furnished under the contract.
- iii. Withholding of any amount due the City of Raleigh as "Liquidated Damages", shall be deducted from payments due to the Contractor.

The City may withhold on account of subsequently discovered evidence, nullify whole or part of any certificate to such extent as may be necessary to protect itself from loss on account of:

- i. Defective work not remedied.

- ii. Claims filed or reasonable evidence indicating probable filing of claims.
- iii. Failure of the Contractor to make payments properly to Subcontractor or for materials or labor.
- iv. A reasonable doubt that the Contract can be completed for the balance unpaid.
- v. Damage to another Contractor.

When the above items have been cleared to the satisfaction of the Transportation Director, payment shall be made for amounts withheld because of them.

23. City's Right to Terminate Contract

If the Contractor should be adjudged as bankrupt, or if he should make a general assignment for the benefit of his creditors, or if a receiver should be appointed on account of insolvency, or if he should persistently or repeatedly refuse or should fail, except in cases for which extension of time is provided, to supply enough properly skilled workmen or proper materials, or if he should fail to make prompt payment to Subcontractors or for material or labor, or persistently discharged laws, ordinances or the instructions of the Transportation Director, or otherwise be guilty of a substantial violation of any provision of the contract, then the City, upon the certificate of the Transportation Director that sufficient cause exists to justify such action, may without prejudice to any other right or remedy and after giving the Contractor seven days written notice, terminate the employment of the Contractor and take possession of the premises and of all materials, tools, appliances, there and finish the work by whatever method it may deem expedient. In such case, the Contractor shall not be entitled to receive any further payment until the work is finished. If the unpaid balance of the contract price shall exceed the expense of finishing the work, including compensation for additional managerial and administrative services, such excess shall be paid to the Contractor. If such expense shall exceed the unpaid balance, the Contractor shall pay the difference to the City. The expense incurred by the owner as herein provided, and the damage incurred through the Contractor's default, shall be certified by the Transportation Director.

24. Contractor's Right to Stop Work or Terminate Contract

If the work should be stopped under an order of any Court, or other public authority, for a period of three months, through no act or fault of the Contractor or of anyone employed by him, then the Contractor may, upon seven days written notice to the Transportation Director, stop work or terminate this contract and recover from the City payment for all work executed and loss sustained upon any plant or materials and reasonable profit and damages.

25. Liability Insurance

The Contractor shall maintain such insurance as will protect him from claims under workman's compensation acts and such other insurance as will protect him and the City from any other claims for damages for property damage and personal injury, including death, which may arise from operations under this contract whether such operations be by himself, or by any subcontractor or anyone directly or indirectly employed by either of them. Certificates of insurance shall be filed with the Transportation Director, if he so requires, and shall be subject to his approval for adequacy of protection. Policies of insurance coverage for personal liability and property damage shall be submitted.

26. Care of Work

- A. The Contractor shall be responsible for all damages to person or property that occur as a result of his fault or negligence in connection with the prosecution of the work and shall be responsible for the proper care and protection of all materials delivered and work performed until completion and final acceptance, whether or not the same has been covered in whole or in part by payments made by the City of Raleigh.
- B. In an emergency affecting the safety of life or property, including adjoining property, the Contractor, without special instructions or authorization is authorized to act at his discretion to prevent such threatened loss or injury and he shall so act. He shall likewise act if instructed to do so by the City of Raleigh. Any compensation claimed by the Contractor on account of such emergency work will be determined by the City of Raleigh as provided in Section 16 - Changes in Work under General Conditions.
- C. The Contractor shall avoid damage as a result of his operations to existing sidewalks, streets, curbs, pavements, utilities (except those which are to be replaced or removed), adjoining property, etc., and he shall at his own expense completely repair any damage thereto caused by his operations.
- D. The Contractor shall shore up, brace, underpin, secure, and protect as may be necessary, all foundations and other parts of existing structures adjacent to, adjoining, and in the vicinity of the site, which may be in any way affected by the excavations or other operations connected with the construction of the improvements embraced in this contract. The Contractor shall be responsible for the giving of any and all required notices to any adjoining or adjacent property owner or other party before the commencement of any work. The Contractor shall indemnify and save harmless the City of Raleigh from any damages on account of settlements or the loss of lateral support of adjoining property and from all loss or expense and all damages for which the City of Raleigh may become liable in consequence of such injury or damage to adjoining and adjacent structures and their premises.
- E. Any claim for damage arising under this contract shall be made in writing to the party liable within reasonable time of the first observance of such damage.

27. Indemnity

The Contractor shall indemnify, save harmless, and defend the City against all losses and claims, demands, payments, suits, actions, recoveries, and judgments of every nature and description brought or recovered against it by reason of any act or omission of the said Contractor, his agents and employees, in the execution of work or in the guarding of it.

28. Safety and Accident Prevention

A. General

The Contractor shall exercise proper precautions at all times for the protection of persons and property and shall be responsible for all damages to persons or property, either on or off the site, which occur as a result of his prosecution of the work. The Contractor shall abide by all applicable safety standards and regulations contained in the Occupational Safety and Health Act, for the construction industry and any other applicable Laws.

- i. All excavation and trenching work shall conform to OSHA requirements under 29 CFR Part 1926 Subpart P and any other applicable requirements.
- ii. The Contractor shall have an employee who is a designated competent person as described under OSHA regulations, 29 CFR Part 1926 Subpart P. The person shall be capable of identifying existing or predictable hazards in the surroundings, or working conditions which are unsanitary, hazardous, or dangerous to employees, and who has authorization to take prompt corrective measures to eliminate them.
- iii. The Contractor shall provide and maintain safety equipment as outlined under OSHA 29 CFR Part 1926 Subpart P and other applicable safety provisions, which include trench boxes, ladders, shoring, barricades, warning vests, gas monitors, meter for hazardous atmospheres and other necessary safety equipment to protect the employees and the job site.

B. Records

The Contractor shall maintain an accurate record of all cases of death, occupational diseases, and injury requiring medical attention or causing loss of time from work, arising out of and in the course of employment on work under the contract. The Contractor shall promptly furnish the City of Raleigh with reports concerning these matters.

C. Indemnity

The Contractor shall indemnify and save harmless the City of Raleigh from any claims for damages resulting from personal injury and/or death suffered or alleged to have been suffered by any person as a result of any work conducted under this contract.

29. Bidding Process and Guaranty Bonds

A. Bidding Process

The City of Raleigh's bidding process policy is regulated by the North Carolina State GS 143 129, GS 143 131 and City of Raleigh Standard Procedure 501 3 which define Formal and Informal public contract.

- i. Formal Contracts, as described by GS 143131 and City of Raleigh Standard Procedure 5013(4.1), are those contracts for construction or repair work that require expenditure of \$500,000.00 or more; and for the purchase or lease purchase of apparatus, supplies, materials or equipment that require an expenditure of \$90,000.00 or more.
- ii. Informal Contracts, as described by GS 143131 and City of Raleigh Standard Procedure 5013(4.2), are those contracts for construction or repair work that require expenditure of \$5,000.00 to \$499,999.00; and for the purchase or lease purchase of apparatus, supplies, materials or equipment that require expenditure of \$5,000.00 to \$89,999.00.
- iii. All Formal Bids as described in 29.01(a), shall be accompanied by a deposit equal to not less than 5 percent of the total amount of the Bid in the form of cash,

cashier's check, a certified check or a bid bond by a surety authorized to do business in the State of North Carolina.

B. Guaranty Bonds

i. Guaranty Bonds for Formal Contracts

- a. The successful bidder in a formal contract, within ten (10) days after the notice of award is received by him, at the Department of Transportation's request shall provide the City of Raleigh with a contract payment bond and a contract performance bond, each in an amount equal to 100 percent of the amount of the contract. All bonds shall be in conformance with GS 44A33. The corporate surety furnishing the bonds shall be authorized to do business in the State of North Carolina.
- b. The successful bidder's failure to execute the contract and file acceptable bonds within ten (10) days after the notice of award is received by him will be just cause for the forfeiture of the bid bond or bid deposit and rescinding the award of the contract. Award may then be made to the next lowest responsible bidder or the work may be readvertised and constructed under contract, or otherwise as the City of Raleigh may decide.

ii. Guaranty Bonds for Informal Contracts

- a. The successful bidder, within ten (10) days after the notice of award is received by him, shall provide a performance and payment bond in the amount of 100% of the amount of the contract.
- b. No performance bond or payment bond will be required for individual construction contracts if the total cost is less than \$100,000.00. A performance bond and payment bond for the full amount of the contract is required for all construction contracts over \$50,000.00 if the contract is part of a project with a total cost of over \$299,999.99. In place of the bonds the Contractor may deposit money, a certified check, or acceptable government securities.

30. Sanitary Facilities

The Contractor shall furnish, install, and maintain ample sanitary facilities for the workers. As the needs arise, a sufficient number of enclosed temporary toilets shall be conveniently placed as required by the sanitary codes of the State and City of Raleigh. Drinking water shall be provided from an approved source, so piped or transported as to keep it safe and fresh and served from single service containers or satisfactory types of sanitary drinking stands or fountains. All such facilities and services shall be furnished in strict accordance with existing and governing health regulations.

31. Use of Premises

- A. The Contractor shall confine his equipment, storage of materials, and construction operations to the contract limits as shown on the Drawings or if no contract limits are shown, to the right-of-way shown and as prescribed by ordinances or permits or as may

be directed by the City of Raleigh and shall not unreasonably encumber the site or public rights of way with his materials and construction equipment.

- B. The Contractor shall comply with all reasonable instructions of the City of Raleigh and the ordinances and codes of the City of Raleigh, regarding signs, advertising, traffic, fires, explosives, danger signals, and barricades.

32. Liens

Neither the final payment nor any part of the retained percentage shall become due until the Contractor, shall deliver to the City a complete release of all liens arising out of the contract, or receipts in full in lieu thereof and, if required in either case, an affidavit that so far as he has knowledge or information the releases and receipts include all labor and materials for which a lien could be filed but the Contractor may, if any subcontractor refuses to furnish a release or receipt in full, furnish a bond satisfactory to the Transportation Director, to indemnify the City against any lien. If any lien remains unsatisfied after all payments are made, the Contractor, shall refund to the City all monies that the latter may be compelled to pay in discharging such a lien, including all costs and a reasonable attorney's fee.

A copy of the Affidavit is included with the Payment Bond Contract and shall be submitted with the Contractor's request for final payment.

33. Working Time Restrictions

A. Intermediate Contract Time No. 1

No work on or street obstruction shall occur during the peak traffic hours of 7:00 a.m.-9:00 a.m. or 4:00 p.m.-6:00 p.m., Monday through Friday, on the following streets.

- i. Any street within the City having a marked centerline or having marked lanes.

Work adjacent to traffic lanes may occur during these hours if proper signage and safety precautions are affected as described in latest edition of the Manual on Uniform Traffic Control Devices.

The Contractor shall have monies withheld due to public inconvenience, obstruction and delay to traffic, safety and other considerations, for any work performed on time restricted streets during 7:00 a.m.-9:00 a.m. or 4:00 p.m.-6:00 p.m., Monday-Friday at the rate of \$500.00 for every 15 minutes of violation or fraction thereof.

No traffic lane closure (through or turn lane) shall occur on **Red Alert Days**. Red Alert Days are determined by North Carolina Ozone Forecast Center, Division of Air Quality.

The Contractor shall notify the Transportation Director 48 hours in advance of any work scheduled on weekends.

34. Holiday Time Restrictions

The Contractor shall not narrow or close a lane of traffic on any road, detain and/or alter the traffic flow, and/or perform any work on or during holiday weekends, special events, or any other time when traffic is unusually heavy, including the following schedules without first obtaining approval from the City of Raleigh project representative:

- A. For unexpected occurrence that creates unusually high traffic volumes, as directed by the Engineer.
- B. For New Year's Day, between the hours of 6:00 P.M. December 31st and 7:00 A.M. January 2nd. If New Year's Day is on a Friday, Saturday, Sunday or Monday, then until 7:00 A.M. the following Tuesday.
- C. For Easter, between the hours of 6:00 P.M. Thursday and 7:00 A.M. Monday.
- D. For Memorial Day, between the hours of 6:00 P.M. Thursday and 7:00 A.M. Tuesday.
- E. For Juneteenth, between the hours of 6:00 P.M. the day before Juneteenth and 7:00 A.M. the day after Juneteenth. If Juneteenth is on a Friday, Saturday, Sunday, or Monday, then between the hours of 6:00 P.M. the Thursday before Juneteenth and 7:00 A.M. the Tuesday after Juneteenth.
- F. For Independence Day, between the hours of 6:30 A.M. the day before Independence Day and 8:00 P.M. the day after Independence Day. If Independence Day is on a Friday, Saturday, Sunday, or Monday, then between the hours of 6:30 A.M. the Thursday before Independence Day and 8:00 P.M. the Tuesday after Independence Day.
- G. For Labor Day, between the hours of 6:00 P.M. Thursday and 7:00 A.M. Tuesday.
- H. For Veteran's Day, between the hours of 6:00 P.M. November 10th and 7:00 A.M. November 12th. If Veteran's Day is on a Friday, Saturday, Sunday, or Monday, then between the hours of 6:30 A.M. the Thursday before Independence Day and 8:00 P.M. the Tuesday after Veteran's Day.
- I. For Thanksgiving Day, between the hours of 6:00 P.M. Tuesday and 7:00 A.M. Monday.
- J. For Christmas, between the hours of 6:00 P.M. the Friday before the week of Christmas Day and 7:00 A.M. the following Tuesday after the week of Christmas Day.

Holidays and holiday weekends shall include New Year's, Easter, Memorial Day, Juneteenth, Independence Day, Labor Day, Thanksgiving and Christmas. The Contractor shall schedule his work so that lane closures are not required during these periods, unless otherwise directed by the Engineer.

The time of availability for this intermediate contract work shall be the time the Contractor begins to install all traffic control devices for lane closures according to the time restrictions stated herein and place traffic in the existing traffic pattern.

The Contractor shall have monies withheld due to public inconvenience, obstruction and delay to traffic, safety, and other considerations, for any work performed during Holiday Time Restrictions at the rate of \$500.00 for every 15 minutes of violation or fraction thereof.

35. Assignment

Neither party to the contract shall assign the contract or sublet it as a whole without the written consent of the other, nor shall the Contractor assign any monies due or to become due to him hereunder, without previous written consent of the City Council of the City of Raleigh.

36. Citizen Notification

The CONTRACTOR shall post “No Parking” signs in conspicuous places facing traffic a minimum of 24 HOURS prior to actual work with a maximum spacing of 100’ of center required. A closer spacing may be required as directed by the Raleigh Police Department. Signs may be obtained from the City. All sign posts and mounting hardware shall be provided by the contractor.

The time of day the No Parking signs and Notices of Work are posted should be recorded along with the license numbers of cars parked on the street at that time and a copy made available for the TRANSPORTATION DIRECTOR and the POLICE DEPARTMENT if towing is necessary.

If towing is necessary, the City of Raleigh Police Department will make the final decision if the vehicles are to be towed. The time and location in which the “No Parking” signs were posted shall be documented and records provided (photos, etc.) to RPD. The times that Notices of Work were distributed will also be a considering factor for the towing of vehicles.

On the day of actual work, any towing necessary may be carried out under City of Raleigh Codes and shall be initiated by the contractor’s superintendent or their designee. Per city code, towing can be initiated under authority of Section 11-2181 and Section 12-7006, Section A, Paragraph 6. The non-emergency Police contact number is 919-829-1911.

Special permission may be required by agencies performing work within the street right-of-way under the following conditions. This permit may be required when:

- A. The traveled portion of the roadway is obstructed between the hours of 7 a.m. to 9 a.m. and 4 p.m. to 6 p.m. if the street involved is marked with either painted center lines or lane lines.
- B. Any street which is totally closed to through traffic.
- C. Any streets within the Central Business District

The Contractor shall notify the City during distribution of citizen notifications if the street meets the above criteria. Any needed permits shall be coordinated through the Transportation Maintenance Division, Right-of-Way Services in advance. The Transportation Director has the authority to approve or deny issuance of any permit.

37. Separate Contracts

The City reserves the right to let other contracts in connection with this work. The Contractor shall afford other Contractors reasonable opportunity for the introduction and storage of their materials and the execution of their work and shall properly connect and coordinate his work with others.

38. Subcontracted Work and Subcontractors

- A. The Contractor shall perform a minimum 50% of the work under the contract with his own forces. In addition, the Contractor shall perform the final resurfacing overlay on a minimum 50% of the total number of streets under the contract with his own forces. Unless otherwise stated elsewhere in the contract, the Contractor shall not subcontract more than 50% of the work stipulated in this contract.

- B. The Contractor shall, as soon as practicable after the signing of the contract, notify the Transportation Director in writing of the names of subcontractors proposed for the work and shall not employ any subcontractors that the Transportation Director may within a reasonable time object to as incompetent or unfit. The Contractor agrees that he is as fully responsible to the City for the acts and omissions of his subcontractor and of persons either directly or indirectly employed by them, as he is for the acts and omissions of persons directly employed by him. Nothing in the Contract Documents shall create any contractual relation between any subcontractor and the City.
- C. The Contractor shall obtain approval of subcontractors as well as any change in subcontractors during the work on the contract from the Transportation Director. A period of seven (7) days minimum is required for the approval of a subcontractor.

39. Points and Instructions

The Contractor shall provide reasonable and necessary opportunities and facilities for setting points and making measurements. He shall not proceed until he has made timely demand upon the Transportation Director for, and has received from him, such points and instructions as may be necessary as the work progresses. The work shall be done in strict conformity with such points and instructions.

The Contractor shall carefully preserve benchmarks, reference points and stakes, and in case of willful or careless destruction, he shall be charged with the resulting expense and shall be responsible for any mistakes that may be caused by their unnecessary loss or disturbance.

40. Status of Transportation Director

The Transportation Director or his duly authorized agent shall have general supervision and direction of the work. He has authority to stop the work wherever such stoppage may be necessary to ensure proper execution of the contract. He shall also have authority to reject all work and materials which do not conform to the contract, to direct the application of force to any portion of the work, as in his judgment is required, and to order the force increased or diminished, and to decide questions which arise in the execution of the work.

41. Transportation Director's Decision

The Transportation Director shall, within a reasonable time after their presentation to him, make decisions in writing on all claims of the City or the Contractor and on all other matters relating to the execution and progress of the work or the interpretation of the contract documents. All such decisions of the Transportation Director shall be final.

42. Lands for Work

The City shall provide the lands upon which the work under this contract is to be done, except that the Contractor shall provide land required for the erection of temporary construction facilities and storage of his materials, together with right of access to same.

43. Cleaning Up

The Contractor shall, as directed by the Transportation Director or their designee, remove from the City's property and from all other public and private property, at his own expense, all temporary structures,

rubbish, millings, waste asphalt, traffic control devices, equipment and other waste materials resulting from contract operations.

44. Access to Property

The Contractor shall, where necessary, provide and maintain access to and from all properties along the line of his work.

45. Safeguards

The Contractor shall, where necessary, provide and maintain access to and from all properties along the line of his work.

The Contractor shall provide, erect and maintain adequate barricades, warning signs, and lights at all excavations, closures, detours and points of danger.

46. Construction Surveying and Layout

- A. The City shall furnish all surveys unless otherwise specified.
- B. The Transportation Director will set sufficient points to establish alignment and grade. The Contractor shall be responsible for preserving all stakes and marks.

47. Materials Sampling and Testing

All tests of material shall be made by a recognized and approved testing laboratory designated by the Transportation Director. The expense of such tests shall be borne by the City unless otherwise specified.

The City shall also have right to test and reject materials based on current NCDOT/ACI testing standards.

The Engineer shall have the option to reject request for testing due to the Contractor's inadequate preparation of material or other reasonable causes determined by the Engineer as necessary for the delay of testing. The Contractor shall notify the Transportation Director 48 hours ahead of time for the needed test.

48. Tools, Plant and Equipment

If at any time before the commencement or during the work, tools, plant, or equipment appear to the Transportation Director to be insufficient, inefficient, or inappropriate to secure the quality of the work required or the proper rate of progress, the Transportation Director may order the Contractor to increase their efficiency, to improve their character, to augment their number, or to substitute new tools, plant or equipment as the case may be, and the Contractor must conform to such order; but the failure of the Transportation Director to give such an order shall not relieve the Contractor to secure the quality of work and the rate of progress necessary to complete the work within the time required.

49. Measurement of Quantities

The quantities of work performed will be computed by the Transportation Director on the basis of measurements taken by him or his assistants, and these measurements shall be final and binding. The specifications shall designate the manner in which the measurements of the various types of work shall be measured.

50. Working Day Defined

A day shall be counted as a working day in the opinion of the Transportation Director if conditions would permit the Contractor to do six (6) hours of work within daylight hours. Days of delay due to acts of God, strikes, court orders, and things of like nature causing delay of the work shall not be counted as a working day. The Transportation Director or their designee shall keep a daily record of working conditions and when requested to do so, they shall furnish the Contractor within a reasonable time the number of working days that have elapsed.

Unless crews are on site prior to 1:00 p.m. of any workday, the Transportation Director has the right to refuse any work that the Contractor may do. To start work after 1:00 p.m. on a workday, the Contractor must have prior permission from the Transportation Director. Should this occur, it will be counted as a working day that the Contractor should have worked. It will not be counted as a day of delay. When work is to resume, one (1) day prior notice must be given to the Transportation Director. That work will begin the next day.

Additional weekend work locations may be designated at the discretion of the Transportation Director. In such cases, the City will provide advance notice to the Contractor, and a mutually agreed-upon date will be scheduled for the weekend work to proceed.

52. Project Time Defined

Project time shall consist of all calendar days, including weekends and holidays, from the contract notice to proceed date through the specified number of days allowed for the completion of the project in the contract document. The Contractor has been given a project time inclusive of an anticipated amount of bad weather, be it due to the winter months or abnormal rainfall during the remainder of the calendar year.

53. Guarantee of Work

The Contractor shall guarantee his work performed under his contract against failures or trouble due to faulty workmanship or materials for a period of twelve (12) months from the date of acceptance of the work.

54. Force Account Work

Force account work shall be performed when pricing associated with changes in work in Item 15 cannot be agreed upon by the City and Contractor.

No work shall begin without the express approval of the Transportation Director or his authorized agent.

All information shall be submitted and approved along with recordkeeping performed in accordance with the North Carolina Department of Transportation Standard Specifications Article 109-3.

55. Disposal of Waste Materials from Street and any Other Types of Construction

Disposal of all waste material from construction sites shall be made in strict accordance with all City ordinances pertaining to disposal of construction waste. It shall be the responsibility of the Contractor to secure the necessary permits and provide all information required to secure said permits. The Contractor

shall designate the disposal site prior to beginning construction and in the event waste material is to be disposed of on private property a letter from the property owner shall be furnished to the Transportation Director granting the Contractor or his agent such permission and listing the requirements made by the property owner or the Contractor, if any.

56. Contractor License

All invited bidders and contractors shall be advised that those who submit formal bids on this project must be licensed in the State of North Carolina whether he (they) is/are a resident or nonresident of this State, in accordance with GS 87 10 and shall be advised that they must show evidence of a license issued by the North Carolina Licensing Board for General Contractors before the bid is considered. The bidders are advised that Article 39, "Subcontracted Work and Subcontractors," of the General Conditions shall be strictly adhered to during the term of this contract.

57. Emergency Work Crew

The Contractor and/or the Contractor's subcontractors shall provide an emergency repair crew with adequate trucks and other equipment available when needed to make repairs, clean up, signing and other work required in connection with this contract. This repair crew shall be on call during nonworking hours and during weekends and holidays. The name, address and phone number of at least two responsible members of this crew shall be provided the Transportation Director or his representatives prior to beginning any work. The members of this crew shall be based, reside, live or stay in Wake County during the periods that they are on call. Should this "emergency" crew be unavailable for any reason when needed, the City shall have the right to have the required work performed by the quickest means available and the Contractor shall be back charged at a rate of two (2) times the total cost to the City.

58. Construction Water

- A. Contractors are responsible for securing adequate construction water for their job sites.
- B. All construction water usage must be metered and will be billed to the Contractor. The Contractor must contact the Public Utilities Department, Meter Services Division (919-996-3245) to make the applicable arrangements for billing the water usage. The Contractor may provide his own meter or if available upon advance notice to the Public Utilities Department, a meter will be provided. If the Contractor provides his own meter it must meet City standards for the meter and include a backflow device.
- C. Construction water for all City contract projects shall be billed by the City of Raleigh, Public Utilities Department.
- D. Contractors must furnish the following information for water usage.
 - i. Meter location and project name.
 - ii. Address where applicable and responsible party name.
 - iii. Duration of use and frequency of meter reading.
- E. Contractors observed using unmetered water will be fined by the City of Raleigh, Public Utilities Department in accordance with City Code provisions.

- F. Contractors are to reference the Public Utilities Handbook, Part 10, entitled Construction Specifications for Water and Sewer Mains, for additional regulations applicable to construction water usage.

59. Business Assistance Program (BAP) for Minority and Woman-Owned Business Enterprises

A. General

General contract bidders on City of Raleigh contracts are encouraged to include Minority and Woman-Owned Business Enterprises in the performance of contracts and subcontracts for construction and material supply as outlined by City Standard Procedure No. 505 2. MWBE businesses are those having at least 51% ownership by an individual or individuals classified as a racial minority or a female. The City of Raleigh has adopted a goal of 15% for participation by MWBE businesses in contracts over \$5,000 awarded for construction by the City. Bidders are to become familiar with the City's BAP guidelines. A copy of these guidelines is available at the office of Business Assistance Program Coordinator.

B. Procedures

- i. All bidders shall make a good faith effort in the recruitment and selection of MWBE businesses as specified in the guidelines.
- ii. The low bidder shall complete the Bidders Report of Subcontractors Selection and Efforts to obtain Minority and Women-Owned Business Enterprise Subcontractors form. A copy of the form is contained elsewhere within the contract document. The form shall be submitted to the office of the Transportation Director within seventy-two (72) hours after the opening of bids.
- iii. All bidders shall complete and submit with their bid the Minority and Women-Owned Business Enterprise Subcontractor/Material Supplier Documentation form. A copy of the form is contained elsewhere within the contract document.
- iv. If the Contractor desires to utilize a subcontractor or material supplier who is not listed in the Business Assistance Directory or who is not approved by the NCDOT, he should contact the City's Business Assistance Program Coordinator to obtain assistance for certification of the subcontractor or material supplier.
- v. A copy of the Current Business Assistance Program Directory is available from the office of the Transportation Director or the Business Assistance Program Coordinator and is free upon request.
- vi. The City of Raleigh is also interested in on-the-job opportunities and training programs which expressly include minorities and women. Documentation regarding these programs is solicited and can provide assistance in reaching the intent of the Business Assistance Program.

60. Dust Control

The Contractor shall, as directed by the Transportation Director provide adequate equipment and use other available means to control the dust during the term of this contract. Failure on the part of the Contractor to correct dust control problems as directed will result in the Transportation Director notifying

the Contractor to comply with the contract provisions. In the event that the Contractor fails to begin such remedial action within 24 hours after receipt of such notice, the Transportation Director may proceed to have the work performed with other forces. The actual cost of the work so performed along with a 20% administrative fee will be deducted from monies due to the Contractor on his contract. Under adverse conditions, the Transportation Director may choose to suspend the Contractor's operations on the project until all dust control problems have been completed to his satisfaction. Such suspension will not justify an extension of contract time.

61. Traffic Control

All traffic control shall be performed in accordance with the latest edition of the Manual on Uniform Traffic Control Devices, MUTCD, and City of Raleigh Code of Ordinances, Part 11, Chapter 2, Article L and Part 11, Chapter 6.

The contractor shall provide all traffic control devices and signs including Portable Changeable Message Signs (PCMS) in accordance with MUTCD to warn the traveling public. PCMS are required on all streets with four (4) or more marked lanes or traffic volume as designated by the City. PCMS shall be installed at least three (3) days in advance of work and maintained throughout the duration of the work.

Traffic control plans and pedestrian plans shall be required for marked streets or as directed by the Transportation Director or their designee to meet site conditions. Plans shall be approved before commencement of the work.

Two-way traffic shall be maintained at all times unless otherwise approved by the traffic control plan. Total road closures shall not be allowed.

Any work performed without traffic control per MUTCD, will not be paid for by the Owner.

62. Clearing Tree Limbs and Vegetation

It shall be the responsibility of the Contractor to remove vegetation and tree limbs less than 6" in diameter from the street right-of-way that present an obstruction to performing street maintenance on the streets listed in the Contract. No separate payment will be made for clearing tree limbs and vegetation as such work will be incidental to resurfacing.

The Contractor shall notify the City at least 30 days in advance of the scheduled work of any tree limbs 6" diameter or greater for the City to have removed.

The Contractor shall notify the City at least 30 days in advance of the scheduled work of any shrubs or ornamental trees on private property that overhang into the right-of-way and present an obstruction. The City will arrange for the obstruction to be removed.

The remainder of this page is left blank intentionally.

STANDARD GENERAL PROVISIONS

All construction shall conform to pertinent OSHA requirements, City of Raleigh Standards and Specifications, and NCDOT Standard Specifications for Roads and Structures. Editions in effect at the time of the bid date shall govern.

1. Construction Progress Schedule and Monthly Meetings

The Contractor shall provide, at the pre-construction conference, a completed City of Raleigh progress schedule. The schedule shall be kept up to date and presented with each month's billing information and shall be made available at the bi-weekly progress meetings and at other times as may be deemed necessary by the Transportation Director or his representative. The Contractor will be represented at bi-weekly progress meetings during the construction of this project. The meetings will be held at the project site or in the City offices as determined by the City.

2. Contract Completion and Progress Schedule Liquidated Damages

This contract shall be completed no later than May 31st, 2026.

Failure to complete the work within the contract time will result in damages due to public inconvenience, obstruction and delay to traffic, safety and other considerations. For each consecutive calendar day in excess of the contract time specified, the Contractor shall pay, or have withheld monies due, a sum of one thousand (\$1000.00) per day. See Contract Article 3, Time of Commencement and Completion.

3. Unit Bid Price

The unit bid price on the items in this contract shall include all materials, labor, equipment, and incidentals necessary to satisfactorily install said items completely in place and accepted unless otherwise mentioned in this contract document.

4. Point of Contact

The Contractor upon start of construction shall provide the Engineer or City Designee with names, addresses, and telephone numbers of two people to be contacted after office hours in case of emergency.

5. Material Tickets

The Contractor shall turn in all material tickets for the purpose of payment to the Project Inspector on a daily basis.

6. Trenches

All trenches shall be backfilled and made safe at the end of each workday. Payment for installation of utility and drainage lines that requires open cut to existing pavement shall include the cost of pavement for repairs (including pavement saw cut and removal) as incidental to the installation of the utility. No separate payment will be made for this work unless otherwise specifically mentioned in this contract.

7. Subsurface Investigation

The Contractor shall make his/her own subsurface investigations. Any information obtained by the City as a result of its own subsurface investigations will be made available upon request. This information is provided for informational purposes only and shall not relieve the Contractor of responsibility for making his own investigations.

8. Grading, Shoulders and Slopes

Shoulders and slopes shall be free of all stone and clods that exceed one inch in diameter. Fine grading (raking) shall take place just before seeding and mulching. No separate payment will be made for shoulder construction or material for shoulder construction as all work necessary to complete the work will be considered incidental to other items in the contract unless otherwise provided in the contract.

9. Traffic Control

The Contractor shall provide all traffic control devices and signs including portable changeable message signs to warn the traveling public in accordance with the latest Manual on Uniform Traffic Control Devices (MUTCD). Two-way traffic shall be maintained at all times, unless otherwise required by the traffic control plan.

Traffic Control items shall be incidental to other items of work in this contract. No direct payment will be made for traffic control.

10. Materials and Equipment Storage

When vehicles, equipment, and materials are not being actively used they shall be moved at least 30 feet away from the edge of any travel way open to traffic (or as directed by the Engineer). All debris shall be immediately moved to a location at least 30 feet from the edge of any travel way open to traffic. If vehicles, equipment, materials, and debris are protected by guardrail or barrier, a 5-foot minimum offset from the rail shall be used.

11. Personnel Parking

A. Personnel

- i. All personnel involved with construction operations shall not park their personal vehicles within the right of way of the project limits for the duration of the construction project. The Contractor shall furnish a parking area that is located off the project limits. The Contractor shall be responsible for daily transportation of all employees to and from the provided parking area and the project site.
- ii. The contractor shall not park equipment on existing sidewalk whenever possible as to limit damage to existing facilities.

- iii. There will be no direct payment for the work covered by this provision. Payment at the contract unit prices for the various items in the contract will be full compensation for all work covered by this provision.

B. Truck Parking

- i. Trucks shall park and/or stage within designated work areas or nearby streets within City of Raleigh right of way. Parking on private property is prohibited without express written permission from the property owner.

12. Sidewalk, Driveway, Curb & Gutter Removal and Replacement

Care should be taken during construction to avoid damaging the existing sidewalk, curb & gutter and pavement outside the immediate construction area. If damaged, it shall be replaced in accordance with the NCDOT Standard Specifications for Roads and Structures/City of Raleigh Standards, as determined by the Engineer, without extra cost to the City. Prior to construction, the Contractor shall inspect the site and report to the Engineer any damages existing before construction.

The Contractor shall be advised that when a portion of any area of concrete driveways, curb and gutter and pavement must be removed, all areas to be removed shall be defined by a machine-sawed joint, prior to removal. Saw cut of concrete driveway, curb & gutter and pavement are considered incidental to removal unless otherwise provided in the contract.

13. Maintenance of Mailboxes, Signs, Miscellaneous Appurtenances

The Contractor shall be required to maintain mailboxes, signs and all miscellaneous appurtenances impacted by construction activities in working order for the duration of construction as directed by the Engineer. Work on the same items shall be done in a timely manner. No separate payment for work on these items will be made as the work will be considered incidental to other items in the contract unless otherwise mentioned in the contract document.

14. Project Completion

When the project is nearing completion, the City will obtain comments from the impacted property owners concerning items that are outstanding, yet to be completed. The Engineer will determine which items have sufficient justification to be included in the final punch-list, and the Contractor will be required to complete these items with no additional payment and in a timely fashion.

15. Coordination with Utility Companies

(See Article 14 of General Conditions)

Utilities as shown on the plans are intended to represent general locations only. It shall be the responsibility of the Contractor, prior to construction, to contact appropriate utility owners and precisely locate utilities that could be affected by the proposed construction. If the utility belongs to the City, the Contractor shall dig sample holes to uncover the utility. The digging of sample holes shall be coordinated with the Engineer who will determine the number of such holes and will schedule the City Surveyor to locate utility vertical and horizontal locations. There is no line item to pay for digging work. Work is considered incidental to other pay items.

The Contractor shall be responsible for repair of any damage to the utility as well as any other damage may be caused due to the disturbance of the utility. The Contractor will not be permitted to submit any claims for delays caused by utility relocation and proposed utility construction.

The City has coordinated designs of utility relocation with private utility owner representatives. Existing utility, design and conflict resolution plans are included as a part of the contract.

The Contractor shall be responsible for coordinating concurrent construction directly with utility owner representatives. Coordination efforts and concurrent construction conflicts will be addressed and discussed during the pre-construction meeting. The City, at the time of pre-construction conference, will provide names, addresses and telephone numbers of private utility owner representatives.

All underground utilities may not have been identified. The Contractor shall call North Carolina One Call to identify underground utilities before starting any digging and/or excavation operation.

The Contractor shall be responsible for field verifying heights and locations of power lines and will be required to maintain the distance from the power lines in accordance with local, State and Federal Safety regulations.

16. Protection of Existing Plants

The work under this item shall consist of the protection of selected trees, shrubs, or other woody plants.

The plants protective fencing shall meet the requirements of City of Raleigh Standard Drawing 50.02. Fencing shall encompass the plants to the drip-line. Deviations from this must be approved by the Engineer.

Plant protective fencing shall be installed prior to beginning any construction on this project. Plant protective fencing shall be constructed at the locations as directed by the Engineer and in accordance with City specification. The fencing shall be maintained in place until all construction operations in that particular area are complete. At completion, only light grading equipment such as small agricultural tractors shall be allowed on the plants' roots. Fill dirt no deeper than two inches shall be allowed under the limb spread of any plant.

No building materials, dirt, or equipment shall be stored inside the protective fencing. Plants that die as a result of the Contractor's negligence shall be removed and replaced as directed by the Engineer at the Contractor's expenses. The new plant shall be guaranteed for a year, planted in the proper season, and planted with approved arboricultural specifications.

The Contractor will be required to cooperate with other contractors, utility companies and others needing access to the project site as (approved by the engineer) to complete the work.

The remainder of this page is left blank intentionally.

GENERAL SPECIFICATIONS

S-01 CONTRACT TIME	2
S-02 LIQUIDATED DAMAGES.....	2
S-03 PRICE ADJUSTMENT-ASPHALT CEMENT FOR PLANT MIX	2
S-04 HOLIDAY WORK RESTRICTIONS.....	3
S-05 SUBMITTAL OF WORKING DRAWINGS (1-31-2025)	3
S-06 FALSEWORK AND FORMWORK (11-30-23).....	8
S-07 UTILITY CONFLICTS.....	14
S-08 CRANE SAFETY (12-5-25)	15
S-09 EROSION FOR SEDIMENT CONTROL STORMWATER CERTIFICATION.....	16
S-10 BURNING RESTRICTIONS.....	22
S-11 TWELVE MONTH GUARANTEE	22

SPECIAL PROVISIONS

SP-01 TRAFFIC CONTROL	23
SP-02 SHOTCRETE REPAIRS (11-30-23).....	27
SP-03 CONCRETE REPAIRS (EPOXY COATING).....	32
SP-04, POLYMER MODIFIED ASPHALT EXPANSION JOINT	34
SP-05, PAINTING EXISTING STEEL STRUCTURE (11-30-23)	40
SP-06, DRIFT/DEBRIS REMOVAL	55
SP-07, UTILITY REPAIR	56

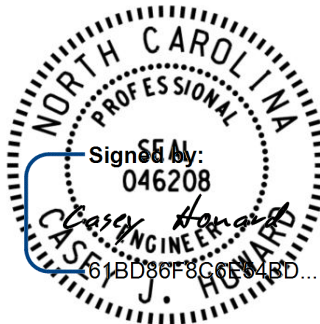

3/12/2026

GENERAL SPECIFICATIONS

All work shall conform to the City of Raleigh Standards or the latest edition of the NCDOT Standard Specifications for Road and Structures. January 2024, the City officially adopted the NCDOT standards. They also utilize their own standard detail drawings, which are unique to City projects and not fully covered by NCDOT standards. If a required detail is not included in the contract documents or on the City of Raleigh Website, the North Carolina Department of Transportation (NCDOT) Roadway Standard Drawings shall apply. While Raleigh has its own set of standard detail drawings and specifications, it defers to NCDOT standards when local specifications do not cover a particular detail. Any conflicts between the NCDOT standards and the City's details should be addressed by the City's Engineer.

S-01 CONTRACT TIME

The Contract Time will begin upon the issuance of the Notice to Proceed and will extend **120** calendar days thereafter.

S-02 LIQUIDATED DAMAGES

Liquidated Damages will be assessed at the rate of **\$1,000.00** per calendar day for failure to complete the Project within the Contract Period.

S-03 PRICE ADJUSTMENT-ASPHALT CEMENT FOR PLANT MIX

“Asphalt Binder for Plant Mix” will be in accordance with Section 620 of the NCDOT 2024 Standard Specifications.

The Bidder shall consider that the City will make adjustments in payments due the Contractor where it has been determined that the average terminal F.O.B. selling price of asphalt cement has fluctuated.

The Base Price Index for Asphalt Cement for this project is set at **\$542.50** per ton.

This Base Price Index represents an average F.O.B. selling price of asphalt cement at supplier’s terminals on **3/1/2026** as determined by the North Carolina Department of Transportation from a survey of terminals located in North Carolina and adjacent states.

<https://connect.ncdot.gov/projects/construction/Pages/Pavement-Construction-Prices.aspx>

Payment will be made under: If the price changes the price at the time of invoice will be the Asphalt Cement Base Price Index

Pay Item

ASPHALT BINDER FOR PLANT MIX

Pay Unit

TON

S-04 HOLIDAY WORK RESTRICTIONS

No work shall be performed on the Project which is subject to measurement or payment when the City offices are closed for observed City holidays. This restriction does not relieve the Contractor from the responsibility of ensuring the safety and well-being of pedestrian and vehicular traffic, and for the protection of public and private property.

In emergencies and certain other conditions deemed necessary by the Engineer, the Contractor may be directed to work on weekends or holidays. There will be no separate measurement or payment for work done under these directives other than those established in the Contract.

S-05 SUBMITTAL OF WORKING DRAWINGS

(1-31-2025)

GENERAL

Submit working drawings in accordance with Article 105-2 of the *NCDOT Standard Specifications* and this Special Provision. For this Special Provision, “submittals” refers to only those listed in this Special Provision. The list of submittals contained herein does not represent a list of required submittals for the project. Submittals are only necessary for those items as required by the contract. Make submittals that are not specifically noted in this provision directly to the Engineer. Either the Engineer or the City of Raleigh or both will jointly review submittals.

If a submittal contains variations from plan details or specifications or significantly affects project cost, field construction or operations, discuss the submittal with and submit all copies to the Engineer. State the reason for the proposed variation in the submittal. To minimize review time, make sure all submittals are complete when initially submitted. Provide a contact name and information with each submittal. Direct any questions regarding submittal requirements to the Engineer, or the City of Raleigh contacts noted below.

To facilitate in-plant inspection by the City of Raleigh and approval of working drawings, provide the name, address and telephone number of the facility where fabrication will actually be done if different than shown on the title block of the submitted working drawings. This includes, but is not limited to, precast concrete items, prestressed concrete items, FRP systems and fabricated steel or aluminum items.

ADDRESSES AND CONTACTS

For submittals to City of Raleigh, use the following addresses:

Via US mail or other delivery services:

Mr. Jason Holmes, P.E.

City of Raleigh

2550 Operations Way

Raleigh, NC 27604

Submittals may also be made via email.

Send submittals to:

Jason.Holmes@raleighnc.gov

(Jason Holmes, P.E.)

Send an additional e-copy of the submittal to the following address:

Casey.Howard@wsp.com

(Casey Howard, P.E.)

Direct any questions concerning submittal review status, review comments or drawing markups to the following contacts:

Primary Contact:

Mr. Jason Holmes, P.E.

City of Raleigh

Jason.Holmes@raleighnc.gov

Secondary Contact:

Mr. Casey Howard, P.E.

WSP USA

Casey.Howard@wsp.com

SUBMITTAL COPIES

Furnish one complete copy of each submittal, including all attachments, to the Engineer. At the same time, submit a copy of the same complete submittal directly to the City of Raleigh as specified in the tables below.

The first table below covers “Structure Submittals.” The Engineer will receive review comments and drawing markups for these submittals from the City of Raleigh. The second table in this section covers “Geotechnical Submittals.” The Engineer will receive review comments and drawing markups for these submittals from the City of Raleigh.

Unless otherwise required, submit one set of supporting calculations to the City of Raleigh require submittal copies in which case submit a set of supporting calculations to each unit. Provide additional copies of any submittal as directed.

STRUCTURE SUBMITTALS

Submittal	Submittal Required by Structures Management Unit?	Submittal Required by Geotechnical Engineering Unit?	Contract Reference Requiring Submittal ¹
Arch Culvert Falsework	Y	N	Plan Note, SN Sheet & “Falsework and Formwork”
Box Culvert Falsework ⁷	Y	N	Plan Note, SN Sheet & “Falsework and Formwork”
Cofferdams	Y	Y	Article 410-4
Foam Joint Seals ⁶	Y	N	“Foam Joint Seals”
Expansion Joint Seals (hold down plate type with base angle)	Y	N	“Expansion Joint Seals”
Expansion Joint Seals (modular)	Y	N	“Modular Expansion Joint Seals”
Expansion Joint Seals (strip seals)	Y	N	“Strip Seal Expansion Joints”
Falsework & Forms ² (substructure)	Y	N	Article 420-3 & “Falsework and Formwork”
Falsework & Forms (superstructure)	Y	N	Article 420-3 & “Falsework and Formwork”
Girder Erection over Railroad	Y	N	Railroad Provisions
Maintenance and Protection of Traffic Beneath Proposed Structure	Y	N	“Maintenance and Protection of Traffic Beneath Proposed Structure at Station ____”
Metal Bridge Railing	Y	N	Plan Note
Metal Stay-in-Place Forms	Y	N	Article 420-3
Metalwork for Elastomeric Bearings ^{4,5}	Y	N	Article 1072-8
Miscellaneous Metalwork ^{4,5}	Y	N	Article 1072-8
Disc Bearings ⁴	Y	N	“Disc Bearings”

Overhead and Digital Message Signs (DMS) (metalwork and foundations)	Y	N	Applicable Provisions
Placement of Equipment on Structures (cranes, etc.)	Y	N	Article 420-20
Prestressed Concrete Box Beam (detensioning sequences) ³	Y	N	Article 1078-11
Precast Concrete Box Culverts	Y	N	“Optional Precast Reinforced Concrete Box Culvert at Station ____”
Prestressed Concrete Cored Slab (detensioning sequences) ³	Y	N	Article 1078-11
Prestressed Concrete Deck Panels	Y	N	Article 420-3
Prestressed Concrete Girder (strand elongation and detensioning sequences)	Y	N	Articles 1078-8 and 1078-11
Removal of Existing Structure over Railroad	Y	N	Railroad Provisions
<hr/>			
Revised Bridge Deck Plans (adaptation to prestressed deck panels)	Y	N	Article 420-3
Revised Bridge Deck Plans (adaptation to modular expansion joint seals)	Y	N	“Modular Expansion Joint Seals”
Sound Barrier Wall (precast items)	Y	N	Article 1077-2 & “Sound Barrier Wall”
Sound Barrier Wall Steel Fabrication Plans ⁵	Y	N	Article 1072-8 & “Sound Barrier Wall”
Structural Steel ⁴	Y	N	Article 1072-8
Temporary Detour Structures	Y	Y	Article 400-3 & “Construction, Maintenance and Removal of Temporary Structure at Station ____”
TFE Expansion Bearings ⁴	Y	N	Article 1072-8

FOOTNOTES

1. References are provided to help locate the part of the contract where the submittals are required. References in quotes refer to the provision by that name. Articles refer to the *Standard Specifications*.
2. Submittals for these items are necessary only when required by a note on plans.
3. Submittals for these items may not be required. A list of pre-approved sequences is available from the producer or the City of Raleigh.
4. The fabricator may submit these items directly to the City of Raleigh.
5. The two sets of preliminary submittals required by Article 1072-8 of the *NCDOT Standard Specifications* are not required for these items.
6. Submittals for Fabrication Drawings are not required. Submittals for Catalogue Cuts of Proposed Material are required. See Section 5.A of the referenced provision.
7. Submittals are necessary only when the top slab thickness is 18” or greater.

GEOTECHNICAL SUBMITTALS

Submittal	Submittals Required by Geotechnical	Submittals Required by Structures	Contract Reference Requiring Submittal ¹
------------------	--	--	--

	Engineering Unit	Management Unit	
Drilled Pier Construction Plans ²	Y	N	Subarticle 411-3(A)
Crosshole Sonic Logging (CSL) Reports ²	Y	N	Subarticle 411-5(A)(2)
Pile Driving Equipment Data Forms ^{2,3}	Y	N	Subarticle 450-3(D)(2)
Pile Driving Analyzer (PDA) Reports ²	Y	N	Subarticle 450-3(F)(3)
Retaining Walls ⁴	Y; drawings and calculations	Y; drawings	Applicable Provisions
Temporary Shoring ⁴	Y; drawings and calculations	Y; drawings	“Temporary Shoring” & “Temporary Soil Nail Walls”

FOOTNOTES

- A. References are provided to help locate the part of the contract where the submittals are required. References in quotes refer to the provision by that name. Subarticles refer to the *NCDOT Standard Specifications*.
- B. Submit one hard copy of submittal to the Engineer. Submit a second copy of submittal electronically (PDF via email), US mail or other delivery service to the appropriate City of Raleigh. Electronic submission is preferred.
- C. The Pile Driving Equipment Data Form is available from:
<https://connect.ncdot.gov/projects/construction/ConstManRefDocs/PILE%20DRIVING%20EQUIPMENT%20DATA%20FORM.pdf>
 See second page of form for submittal instructions.
- D. Electronic copy of submittal is required. See referenced provision.

S-06 FALSEWORK AND FORMWORK

(11-30-23)

GENERAL

Use this Special Provision as a guide to develop temporary works submittals required by the *NCDOT Standard Specifications* or other provisions; no additional submittals are required herein. Such temporary works include, but are not limited to, falsework and formwork.

Falsework is any temporary construction used to support the permanent structure until it becomes self-supporting. Formwork is the temporary structure or mold used to retain plastic or fluid concrete in its designated shape until it hardens. Access scaffolding is a temporary structure that functions as a work platform that supports construction personnel, materials, and tools, but is not intended to support the structure. Scaffolding systems that are used to temporarily support permanent structures (as opposed to functioning as work platforms) are considered to be falsework under the definitions given. Shoring is a component of falsework such as horizontal, vertical, or inclined support members. Where the term “temporary works” is used, it includes all of the temporary facilities used in bridge construction that do not become part of the permanent structure.

Design and construct safe and adequate temporary works that will support all loads imposed and provide the necessary rigidity to achieve the lines and grades shown on the plans in the final structure.

MATERIALS

Select materials suitable for temporary works; however, select materials that also ensure the safety and quality required by the design assumptions. The Engineer has authority to reject material on the basis of its condition, inappropriate use, safety, or nonconformance with the plans. Clearly identify allowable loads or stresses for all materials or manufactured devices on the plans. Revise the plan and notify the Engineer if any change to materials or material strengths is required.

DESIGN REQUIREMENTS

(A) Working Drawings

Provide working drawings for items as specified in the contract, or as required by the Engineer, with design calculations and supporting data in sufficient detail to permit a structural and safety review of the proposed design of the temporary work.

On the drawings, show all information necessary to allow the design of any component to be checked independently as determined by the Engineer.

When concrete placement is involved, include data such as the drawings of proposed sequence, rate of placement, direction of placement, and location of all construction joints.

When required, have the drawings and calculations prepared under the guidance of, and sealed by, a North Carolina Registered Professional Engineer who is knowledgeable in temporary works design.

If requested by the Engineer, submit with the working drawings manufacturer’s catalog data listing the weight of all construction equipment that will be supported on the temporary work. Show anticipated total settlements and/or deflections of falsework and forms on the working drawings. Include falsework footing settlements, joint take-up, and deflection of beams or girders.

As an option for the Contractor, overhang falsework hangers may be uniformly spaced, at a maximum of 36 inches, provided the following conditions are met:

Member Type (PCG)	Member Depth, (inches)	Max. Overhang Width, (inches)	Max. Slab Edge Thickness, (inches)	Max. Screed Wheel Weight, (lbs.)	Bracket Min. Vertical Leg Extension, (inches)
II	36	39	14	2000	26
III	45	42	14	2000	35
IV	54	45	14	2000	44
MBT	63	51	12	2000	50
MBT	72	55	12	1700	48

Overhang width is measured from the centerline of the girder to the edge of the deck slab. For Type II, III & IV prestressed concrete girders (PCG), 45-degree cast-in-place half hangers and rods must have a minimum safe working load of 6,000 lbs.

For MBT prestressed concrete girders, 45-degree angle holes for falsework hanger rods shall be cast through the girder top flange and located, measuring along the top of the member, 1'-2 ½" from the edge of the top flange. Hanger hardware and rods must have a minimum safe working load of 6,000 lbs.

For link slabs, the top of girders directly beneath the link slab shall be free of overhang falsework attachments or other hardware. Submit calculations and working drawings for overhang falsework in the link slab region.

The overhang bracket provided for the diagonal leg shall have a minimum safe working load of 3,750 lbs. The vertical leg of the bracket shall extend to the point that the heel bears on the girder bottom flange, no closer than 4 inches from the bottom of the member. However, for 72-inch members, the heel of the bracket shall bear on the web, near the bottom flange transition.

Provide adequate overhang falsework and determine the appropriate adjustments for deck geometry, equipment, casting procedures and casting conditions.

If the optional overhang falsework spacing is used, indicate this on the falsework submittal and advise the girder producer of the proposed details. Failure to notify the Engineer of hanger type and hanger spacing on prestressed concrete girder casting drawings may delay the approval of those drawings.

Falsework hangers that support concentrated loads and are installed at the edge of thin top flange concrete girders (such as bulb tee girders) shall be spaced so as not to exceed 75% of the manufacturer's stated safe working load. Use of dual leg hangers (such as Meadow Burke HF-42 and HF-43) are not allowed on concrete girders with thin top flanges. Design the falsework and forms supporting deck slabs and overhangs on girder bridges so that there will be no differential settlement between the girders and the deck forms during placement of deck concrete.

When staged construction of the bridge deck is required, detail falsework and forms for screed and fluid concrete loads to be independent of any previous deck pour components when the mid-span girder deflection due to deck weight is greater than $\frac{3}{4}$ ".

Note on the working drawings any anchorages, connectors, inserts, steel sleeves or other such devices used as part of the falsework or formwork that remains in the permanent structure. If the plan notes indicate that the structure contains the necessary corrosion protection required for a Corrosive Site, epoxy coat, galvanize or metalize these devices. Electroplating will not be allowed. Any coating required by the Engineer will be considered incidental to the various pay items requiring temporary works.

Design falsework and formwork requiring submittals in accordance with the current edition of AASHTO *Guide Design Specifications for Bridge Temporary Works* except as noted herein.

(1) Wind Loads

Table 2.2 of Article 2.2.5.1 is modified to include wind velocities up to 110 mph. In addition, Table 2.2A is included to provide the maximum wind speeds by county in North Carolina.

Table 2.2 - Wind Pressure Values

Height Zone feet above ground	Pressure, lb/ft ² for Indicated Wind Velocity, mph				
	70	80	90	100	110
0 to 30	15	20	25	30	35
30 to 50	20	25	30	35	40
50 to 100	25	30	35	40	45
over 100	30	35	40	45	50

(2) Time of Removal

The following requirements replace those of Article 3.4.8.2.

Do not remove forms until the concrete has attained strengths required in Article 420-16 of the *NCDOT Standard Specifications* and these Special Provisions.

Do not remove forms until the concrete has sufficient strength to prevent surface damage.

Table 2.2A - Steady State Maximum Wind Speeds by Counties in North Carolina

COUNTY	25 YR (mph)	COUNTY	25 YR (mph)	COUNTY	25 YR (mph)
Alamance	70	Franklin	70	Pamlico	100
Alexander	70	Gaston	70	Pasquotank	100
Alleghany	70	Gates	90	Pender	100
Anson	70	Graham	80	Perquimans	100
Ashe	70	Granville	70	Person	70
Avery	70	Greene	80	Pitt	90
Beaufort	100	Guilford	70	Polk	80
Bertie	90	Halifax	80	Randolph	70
Bladen	90	Harnett	70	Richmond	70
Brunswick	100	Haywood	80	Robeson	80
Buncombe	80	Henderson	80	Rockingham	70
Burke	70	Hertford	90	Rowan	70
Cabarrus	70	Hoke	70	Rutherford	70
Caldwell	70	Hyde	110	Sampson	90
Camden	100	Iredell	70	Scotland	70
Carteret	110	Jackson	80	Stanley	70
Caswell	70	Johnston	80	Stokes	70
Catawba	70	Jones	100	Surry	70
Cherokee	80	Lee	70	Swain	80
Chatham	70	Lenoir	90	Transylvania	80
Chowan	90	Lincoln	70	Tyrell	100
Clay	80	Macon	80	Union	70
Cleveland	70	Madison	80	Vance	70
Columbus	90	Martin	90	Wake	70
Craven	100	McDowell	70	Warren	70
Cumberland	80	Mecklenburg	70	Washington	100
Currituck	100	Mitchell	70	Watauga	70
Dare	110	Montgomery	70	Wayne	80
Davidson	70	Moore	70	Wilkes	70
Davie	70	Nash	80	Wilson	80
Duplin	90	New Hanover	100	Yadkin	70
Durham	70	Northampton	80	Yancey	70
Edgecombe	80	Onslow	100		
Forsyth	70	Orange	70		

(B) Review and Approval

The Engineer is responsible for the review and approval of temporary works' drawings.

Submit the working drawings sufficiently in advance of proposed use to allow for their review, revision (if needed), and approval without delay to the work.

The time period for review of the working drawings does not begin until complete drawings and design calculations, when required, are received by the Engineer.

Do not start construction of any temporary work for which working drawings are required until the drawings have been approved. Such approval does not relieve the Contractor of the responsibility for the accuracy and adequacy of the working drawings.

CONSTRUCTION REQUIREMENTS

All requirements of Section 420 of the *NCDOT Standard Specifications* apply.

Construct temporary works in conformance with the approved working drawings. Ensure that the quality of materials and workmanship employed is consistent with that assumed in the design of the temporary works. Do not weld falsework members to any portion of the permanent structure unless approved. Show any welding to the permanent structure on the approved construction drawings.

Provide tell-tales attached to the forms and extending to the ground, or other means, for accurate measurement of falsework settlement. Make sure that the anticipated compressive settlement and/or deflection of falsework does not exceed 1 inch. For cast-in-place concrete structures, make sure that the calculated deflection of falsework flexural members does not exceed 1/240 of their span regardless of whether or not the deflection is compensated by camber strips.

(A) Maintenance and Inspection

Inspect and maintain the temporary work in an acceptable condition throughout the period of its use. Certify that the manufactured devices have been maintained in a condition to allow them to safely carry their rated loads. Clearly mark each piece so that its capacity can be readily determined at the job site.

Perform an in-depth inspection of an applicable portion(s) of the temporary works, in the presence of the Engineer, not more than 24 hours prior to the beginning of each concrete placement. Inspect other temporary works at least once a month to ensure that they are functioning properly. Have a North Carolina Registered Professional Engineer inspect the cofferdams, shoring, sheathing, support of excavation structures, and support systems for load tests prior to loading.

(B) Foundations

Determine the safe bearing capacity of the foundation material on which the supports for temporary works rest. If required by the Engineer, conduct load tests to verify proposed bearing capacity values that are marginal or in other high-risk situations.

The use of the foundation support values shown on the contract plans of the permanent structure is permitted if the foundations are on the same level and on the same soil as those of the permanent structure.

Allow for adequate site drainage or soil protection to prevent soil saturation and washout of the soil supporting the temporary works supports.

If piles are used, the estimation of capacities and later confirmation during construction using standard procedures based on the driving characteristics of the pile is permitted. If preferred, use load tests to confirm the estimated capacities; or, if required by the Engineer conduct load tests to verify bearing capacity values that are marginal or in other high risk situations.

The Engineer reviews and approves the proposed pile and soil bearing capacities.

REMOVAL

Unless otherwise permitted, remove and keep all temporary works upon completion of the work. Do not disturb or otherwise damage the finished work.

Remove temporary works in conformance with the contract documents. Remove them in such a manner as to permit the structure to uniformly and gradually take the stresses due to its own weight.

MEASUREMENT AND PAYMENT

Unless otherwise specified, *Falsework and Formwork* will not be directly measured.

Payment at the contract unit prices for the various pay items requiring temporary works will be full compensation for the above falsework and formwork.

S-07 UTILITY CONFLICTS

It shall be the responsibility of the Contractor to identify and contact all affected utility owners and determine precise locations of all utilities prior to beginning construction. Utility owners shall be contacted a minimum of 48 hours prior to the commencement of operations. Special care shall be used in working around or near existing utilities, protecting them when necessary to provide uninterrupted service. In the event that any utility service is interrupted, the Contractor shall notify the utility owner immediately and shall cooperate with the owner, or his representative, in the restoration of service in the shortest time possible. Existing fire hydrants shall be kept accessible to fire departments at all times.

The Contractor shall adhere to all applicable regulations and follow accepted safety procedures when working in the vicinity of utilities in order to ensure the safety of construction personnel and the public. Utilities damaged by the Contractor due to his negligence will be repaired at the Contractor's expense.

METHOD OF MEASUREMENT

This item will not be directly measured.

PAYMENT

No payment will be paid for this item.

S-08 CRANE SAFETY

(12-5-25)

GENERAL

Comply with the manufacturer specifications and limitations applicable to the operation of any and all cranes and derricks. Prime contractors, sub-contractors, and fully operated rental companies shall comply with the current Occupational Safety and Health Administration (OSHA) regulations.

Submit all items listed below to the Engineer prior to beginning crane operations. Changes in personnel or equipment must be reported to the Engineer and all applicable items listed below must be updated and submitted prior to continuing with crane operations.

CRANE SAFETY SUBMITTAL LIST

- (A) Competent Person:** Provide the name and qualifications of the "Competent Person" responsible for crane safety and lifting operations. The named competent person will have the responsibility and authority to stop any work activity due to safety concerns.
- (B) Riggers:** Provide the qualifications and experience of the persons responsible for rigging operations. Qualifications and experience should include, but not be limited to, weight calculations, center of gravity determinations, selection and inspection of sling and rigging equipment, and safe rigging practices.
- (C) Crane Inspections:** Inspection records for all cranes shall be current and readily accessible for review upon request.
- (D) Certifications:** Crane operators shall be certified by the National Commission for the Certification of Crane Operators (NCCCO) or the National Center for Construction Education and Research (NCCER). Other approved nationally accredited programs will be considered upon request. In addition, crane operators shall have a current CDL medical card. Submit a list of crane operator(s) and include current certification for each type of crane operated (small

hydraulic, large hydraulic, small lattice, large lattice) and medical evaluations for each operator.

MEASUREMENT AND PAYMENT

No direct payment will be made for providing information, certifications and documentation required for *Crane Safety*.

MEASUREMENT AND PAYMENT

No direct payment will be made for *Crane Safety*. All costs shall be considered incidental to items for which direct payment is made.

S-09 EROSION FOR SEDIMENT CONTROL STORMWATER CERTIFICATION

GENERAL

Schedule and conduct construction activities in a manner that will minimize soil erosion and the resulting sedimentation and turbidity of surface waters. Comply with the requirements herein regardless of whether or not a National Pollution discharge Elimination System (NPDES) permit for the work is required.

Establish a chain of responsibility for operations and subcontractors' operations to ensure that the *Erosion and Sediment Control/Stormwater Pollution Prevention Plan* is implemented and maintained over the life of the contract.

- (A) *Certified Supervisor* - Provide a certified Erosion and Sediment Control/Stormwater Supervisor to manage the Contractor and subcontractor operations, insure compliance with Federal, State and Local ordinances and regulations, and manage the Quality Control Program.
- (B) *Certified Foreman* - Provide a certified, trained foreman for each construction operation that increases the potential for soil erosion or the possible sedimentation and turbidity of surface waters.
- (C) *Certified Installer* - Provide a certified installer to install or direct the installation for erosion or sediment/stormwater control practices.
- (D) *Certified Designer* - Provide a certified designer for the design of the erosion and sediment control/stormwater component of reclamation plans and, if applicable, for the design of the project erosion and sediment control/stormwater plan.

ROLES AND RESPONSIBILITIES

- (A) *Certified Erosion and Sediment Control/Stormwater Supervisor* - The Certified Supervisor shall be Level II and responsible for ensuring the erosion and sediment control/stormwater plan is adequately implemented and maintained on the project and for conducting the quality control program. The Certified Supervisor shall be on the project within 24 hours' notice from initial exposure of an erodible surface to the project's final acceptance. Perform the following duties:
- (1) **Manage Operations** - Coordinate and schedule the work of subcontractors so that erosion and sediment control/stormwater measures are fully executed for each operation and in a timely manner over the duration of the contract.
 - (a) Oversee the work of subcontractors so that appropriate erosion and sediment control/stormwater preventive measures are conformed to at each stage of the work.
 - (b) Prepare the required National Pollutant Discharge Elimination System (NPDES) Inspection Record and submit to the Engineer.
 - (c) Attend all weekly or monthly construction meetings to discuss the findings of the NPDES inspection and other related issues.
 - (d) Implement the erosion and sediment control/stormwater site plans requested.
 - (e) Provide any needed erosion and sediment control/stormwater practices for the Contractor's temporary work not shown on the plans, such as, but not limited to work platforms, temporary construction, pumping operations, plant and storage yards, and cofferdams.
 - (f) Acquire applicable permits and comply with requirements for borrow pits, dewatering, and any temporary work conducted by the Contractor in jurisdictional areas.
 - (g) Conduct all erosion and sediment control/stormwater work in a timely and workmanlike manner.
 - (h) Fully perform and install erosion and sediment control/stormwater work prior to any suspension of the work.
 - (i) Coordinate with City of Raleigh, Federal, State and Local Regulatory agencies on resolution of erosion and sediment control/stormwater issues due to the Contractor's operations.
 - (j) Ensure that proper cleanup occurs from vehicle tracking on paved surfaces or any location where sediment leaves the Right-of-Way.
 - (k) Have available a set of erosion and sediment control/stormwater plans that are initialed and include the installation date of Best Management Practices. These practices shall include temporary and permanent groundcover and be properly updated to reflect necessary plan and field changes for use and review by City of Raleigh personnel as well as regulatory agencies.
 - (2) **Requirements set forth under the NPDES Permit** - The City of Raleigh NPDES Stormwater permit (NCS000245) outlines certain objectives and management measures pertaining to construction activities. The permit references *NCG010000*,

General Permit to Discharge Stormwater under the NPDES, and states that the City of Raleigh shall incorporate the applicable requirements into its delegated Erosion and Sediment Control Program for construction activities disturbing one or more acres of land. The City of Raleigh further incorporates these requirements on all contracted bridge and culvert work at jurisdictional waters, regardless of size. Some of the requirements are, but are not limited to:

- (a) Control project site waste to prevent contamination of surface or ground waters of the state, i.e. from equipment operation/maintenance, construction materials, concrete washout, chemicals, litter, fuels, lubricants, coolants, hydraulic fluids, any other petroleum products, and sanitary waste. Inspect erosion and sediment control/stormwater devices and stormwater discharge outfalls at least once every 7 calendar days, twice weekly for construction related *Federal Clean Water Act, Section 303(d)* impaired streams with turbidity violations, and within 24 hours after a significant rainfall event of 0.5 inch that occurs within a 24 hour period.
 - (b) Maintain an onsite rain gauge or use the NCDOT's Multi-Sensor Precipitation Estimate website to maintain a daily record of rainfall amounts and dates. Can be found here: <https://mpe.climate.ncsu.edu/>
 - (c) Maintain erosion and sediment control/stormwater inspection records for review by City of Raleigh and Regulatory personnel upon request.
 - (d) Implement approved reclamation plans on all borrow pits, waste sites and staging areas.
 - (e) Maintain a log of turbidity test results as outlined in the City of Raleigh's Stormwater Design Manual.
 - (f) Provide secondary containment for bulk storage of liquid materials.
 - (g) Provide training for employees concerning general erosion and sediment control/stormwater awareness, the City's NPDES Stormwater Permit NCS000245 requirements, and the applicable requirements of the *General Permit, NCG010000*.
 - (h) Report violations of the NPDES permit to the Engineer immediately who will notify the Division of Water Quality Regional Office within 24 hours of becoming aware of the violation.
- (3) Quality Control Program - Maintain a quality control program to control erosion, prevent sedimentation and follow provisions/conditions of permits. The quality control program shall:

- (a) Follow permit requirements related to the Contractor and subcontractors' construction activities.
- (b) Ensure that all operators and subcontractors on site have the proper erosion and sediment control/stormwater certification.
- (c) Notify the Engineer when the required certified erosion and sediment control/stormwater personnel are not available on the job site when needed.
- (d) Conduct the inspections required by the NPDES permit.
- (e) Take corrective actions in the proper timeframe as required by the NPDES permit for problem areas identified during the NPDES inspections.
- (f) Incorporate erosion control into the work in a timely manner and stabilize disturbed areas with mulch/seed or vegetative cover on a section-by-section basis.
- (g) Use flocculants approved by state regulatory authorities where appropriate and where required for turbidity and sedimentation reduction.
- (h) Ensure proper installation and maintenance of temporary erosion and sediment control devices.
- (i) Remove temporary erosion or sediment control devices when they are no longer necessary as agreed upon by the Engineer.
- (j) The Contractor's quality control and inspection procedures shall be subject to review by the Engineer. Maintain NPDES inspection records and make records available at all times for verification by the Engineer.

(B) *Certified Foreman* - At least one Certified Foreman shall be onsite for each type of work listed herein during the respective construction activities to control erosion, prevent sedimentation and follow permit provisions:

- (1) Foreman in charge of grading activities
- (2) Foreman in charge of bridge or culvert construction over jurisdictional areas
- (3) Foreman in charge of utility activities

The Contractor may request to use the same person as the Level II Supervisor and Level II Foreman. This person shall be onsite whenever construction activities as described above are taking place. This request shall be approved by the Engineer prior to work beginning.

The Contractor may request to name a single Level II Foreman to oversee multiple construction activities on small bridge or culvert replacement projects. This request shall be approved by the Engineer prior to work beginning.

(C) *Certified Installers* - Provide at least one onsite, Level I Certified Installer for each of the following erosion and sediment control/stormwater crew:

- (1) Seeding and Mulching
- (2) Temporary Seeding
- (3) Temporary Mulching
- (4) Sodding

- (5) Silt fence or other perimeter erosion/sediment control device installations
- (6) Erosion control blanket installation
- (7) Hydraulic tackifier installation
- (8) Turbidity curtain installation
- (9) Rock ditch check/sediment dam installation
- (10) Ditch liner/matting installation
- (11) Inlet protection
- (12) Riprap placement
- (13) Stormwater BMP installations (such as but not limited to level spreaders, retention/detention devices)
- (14) Pipe installations within jurisdictional areas

If a Level I *Certified Installer* is not onsite, the Contractor may substitute a Level II Foreman for a Level I Installer, provided the Level II Foreman is not tasked to another crew requiring Level II Foreman oversight.

- (D) *Certified Designer* - Include the certification number of the Level III-B Certified Designer on the erosion and sediment control/stormwater component of all reclamation plans and if applicable, the certification number of the Level III-A Certified Designer on the design of the project erosion and sediment control/stormwater plan.

PRECONSTRUCTION MEETING

Furnish the names of the *Certified Erosion and Sediment Control/Stormwater Supervisor*, *Certified Foremen*, *Certified Installers* and *Certified Designer* and notify the Engineer of changes in certified personnel over the life of the contract within 2 days of change.

ETHICAL RESPONSIBILITY

Any company performing work for the City of Raleigh has the ethical responsibility to fully disclose any reprimand or dismissal of an employee resulting from improper testing or falsification of records.

REVOCATION OR SUSPENSION OF CERTIFICATION

Upon recommendation of the City of Raleigh Engineer to the certification entity, certification for *Supervisor*, *Certified Foremen*, *Certified Installers* and *Certified Designer* may be revoked or suspended with the issuance of an *Immediate Corrective Action (ICA)*, *Notice of Violation (NOV)*, or *Cease and Desist Order* for erosion and sediment control/stormwater related issues. The City of Raleigh Engineer may recommend suspension or permanent revocation of certification due to the following:

- (A) Failure to adequately perform the duties as defined within this certification provision.
- (B) Issuance of an ICA, NOV, or Cease and Desist Order.
- (C) Failure to fully perform environmental commitments as detailed within the permit conditions and specifications.

- (D) Demonstration of erroneous documentation or reporting techniques.
- (E) Cheating or copying another candidate's work on an examination.
- (F) Intentional falsification of records.
- (G) Directing a subordinate under direct or indirect supervision to perform any of the above actions.
- (H) Dismissal from a company for any of the above reasons.
- (I) Suspension or revocation of one's certification by another entity.

Suspension or revocation of a certification will be sent by certified mail to the certificant and the Corporate Head of the company that employs the certificant.

A certificant has the right to appeal any adverse action which results in suspension or permanent revocation of certification by responding, in writing, to the City of Raleigh Engineer within 10 calendar days after receiving notice of the proposed adverse action.

Mr. Jason Holmes, P.E.
City of Raleigh Public Works
2550 Operations Way
Raleigh, NC 27604

Failure to appeal within 10 calendar days will result in the proposed adverse action becoming effective on the date specified on the certified notice. Failure to appeal within the time specified will result in a waiver of all future appeal rights regarding the adverse action taken. The certificant will not be allowed to perform duties associated with the certification during the appeal process.

The City of Raleigh Engineer will hear the appeal and make a decision within 7 days of hearing the appeal. Decision of the City of Raleigh Engineer will be final and will be made in writing to the certificant.

If a certification is temporarily suspended, the certificant shall pass any applicable written examination and any proficiency examination, at the conclusion of the specified suspension period, prior to having the certification reinstated.

Certified Erosion and Sediment Control/Stormwater Supervisor, Certified Foremen, Certified Installers and Certified Designer will be incidental to the project for which no direct compensation will be made.

METHOD OF MEASUREMENT

This item will not be directly measured.

PAYMENT

No payment will be paid for this item.

S-10 BURNING RESTRICTIONS

Open burning is not permitted on any portion of the right-of-way limits established for this project. Do not burn the clearing, grubbing or demolition debris designated for disposal and generated from the project at locations within the project limits, off the project limits or at any waste or borrow sites in this county. Dispose of the clearing, grubbing and demolition debris by means other than burning, according to state or local rules and regulations.

S-11 TWELVE MONTH GUARANTEE

DESCRIPTION

- (A) The Contractor shall guarantee materials and workmanship against latent and patent defects arising from faulty materials, faulty workmanship or negligence for a period of twelve months following the date of final acceptance of the work for maintenance and shall replace such defective materials and workmanship without cost to the City. The Contractor will not be responsible for damage due to faulty design, normal wear and tear, for negligence on the part of the City, and/or for use in excess of the design.
- (B) Where items of equipment or material carry a manufacturer's guarantee for any period in excess of twelve months, then the manufacturer's guarantee shall apply for that particular piece of equipment or material. The City's first remedy shall be through the manufacturer although the Contractor is responsible for invoking the warranted repair work with the manufacturer. The Contractor's responsibility shall be limited to the term of the manufacturer's guarantee. The City would be afforded the same warranty as provided by the Manufacturer.

This guarantee provision shall be invoked only for major components of work in which the Contractor would be wholly responsible for under the terms of the contract. Examples would include pavement structures, bridge components, and sign structures. This provision will not be used as a mechanism to force the Contractor to return to the project to make repairs or perform additional work that the City would normally compensate the Contractor for. In addition, routine maintenance activities (i.e. mowing grass, debris removal, ruts in earth shoulders,) are not parts of this guarantee.

Appropriate provisions of the payment and/or performance bonds shall cover this guarantee for the project.

SP-01 TRAFFIC CONTROL

BEGINNING WORK AND STREET CLOSINGS

The Contractor shall install advance warning signs for the Project. These signs shall be in place for at least (7) days in advance before construction activity begins and maintained throughout the duration of the work. The Contractor shall begin construction activity on a street on the scheduled date for the closing of the travel lane.

During daily construction work hours, the Contractor shall maintain two-way traffic at all times unless otherwise required by the traffic control plan. Total road closures will not be allowed. During periods of construction inactivity, all lanes of traffic will be open unless otherwise shown on the plans or noted in the specifications.

RIGHT-OF-WAY USE PERMIT

The Contractor shall be responsible for obtaining lane closure permits. Lane closure permits shall be obtained by contacting the City of Raleigh Development Services Department, Right-of-Way Services at (919-996-2483) in advance (24 hours or greater). Lane closure permits are required on the following streets:

- a. Any street within the City having a marked centerline, or having marked lanes.
- b. All streets with five (5) or more traffic lanes at the point of work, all streets with two traffic lanes in each direction divided by a median, and all streets within the Central Business District (CBD), the area bounded by East Street, West Street, South Street, and Peace Street.

The City of Raleigh's online application

[Permit and Development Portal Help Center | Raleighnc.gov](https://www.raleighnc.gov/development-services/permits)

TRAFFIC CONTROL PLAN

Traffic control will be performed by the Contractor based upon the Traffic Control Special Provisions. The Traffic Control Special Provisions may refer to plan sheets for major work items, the City of Raleigh's Standard Detail Drawings, details in the 2024 NCDOT Roadway Standard Drawings Division 11, latest edition of the Manual on Uniform Traffic Control Devices (MUTCD), or the City of Raleigh Code of Ordinances Part 11, Chapter 2, Article L.

The Contractor shall be thoroughly familiar with the City of Raleigh's Standard Detail Drawings, the latest edition of the Manual on Uniform Traffic Control Devices (MUTCD), or the City of Raleigh Code of Ordinances Part 11, Chapter 2, Article L, the NCDOT Roadway Standard Drawings Division 11 and NCDOT Standard Specifications. All traffic control devices and procedures shall conform to the requirements of the current edition of the Federal Highway Administration (FHWA) Manual on Uniform Traffic Control Devices (MUTCD), the current

edition of the North Carolina Department of Transportation (NCDOT) Supplement to the Manual on Uniform Traffic Control Devices for Streets and Highways, the NCDOT Roadway Standard Drawings and the current edition of the NCDOT Standard Specification for Roads and Structures, and the City of Raleigh Code of Ordinances Part 11, Chapter 2, Article L.

The Contractor shall maintain the traffic control as described herein unless the Contractor submits an alternate traffic control plan to the Engineer and it is approved by the Engineer. The Engineer may direct the Contractor to modify the traffic control if, in the Engineer's opinion, traffic is not moving safely or efficiently.

Traffic Control Phasing for this project shall be in accordance with the City of Raleigh's Standard Detail Drawings, the Traffic Control Plans and the reference Diagrams from the 2024 NCDOT Roadway Standard Drawings. The Contractor shall adhere rigidly to these plans and diagrams. If these diagrams are not typical for field conditions, the diagrams may be combined or altered upon approval of the Engineer. The standard plan diagrams are the minimum required. Additional signs, cones, drums, barricades and warning devices may be used, but at no time will less than what is specified on the plans, in the standards, and on diagrams be acceptable.

MAINTENANCE OF TRAFFIC

The Contractor shall maintain all travel lanes in accordance with the City of Raleigh's Standard Detail Drawings, the Traffic Control Plan sheets, and the 2024 NCDOT Roadway Standard Drawings Division 11 diagrams referenced in the Traffic Control Phasing.

Construction or maintenance work that involves closure of a lane of traffic will not be allowed during the peak flow hours, unless otherwise specified in the Contract Documents. Reference ICT for lane closure time Restrictions.

The Contractor shall use flagger control in accordance with the 2024 NCDOT Roadway Standard Drawings Division 11 diagrams referenced in the Traffic Control Phasing.

In areas of drop offs and low shoulders, the Contractor shall backfill up to the edge and elevation of the existing pavement in accordance with 2024 NCDOT Standard Specification for Roads and Structures.

The Contractor will be required to maintain ingress and egress to all businesses and dwellings, and easy access to Fire hydrants in accordance with Section 11 of the 2024 NCDOT Standard Specification for Roads and Structures.

The Contractor shall provide adequate drainage under driveways and within the Project area for the duration of the Project.

The Contractor shall mark all hazards within the Project limits with well-maintained signs, barricades, warning and/or channelizing devices.

TRAFFIC CONTROL DEVICES

The Contractor shall furnish, install, operate, relocate, maintain and remove all temporary traffic control devices and signs including Portable Changeable Message Signs (PCMS) necessary for controlling traffic in accordance with the latest edition of the Manual on Uniform Traffic Control Devices (MUTCD) to warn the traveling public. PCMS are required on all streets with four (4) or more marked lanes or as specified on the project's maintenance of traffic plans. PCMS shall be installed at least seven (7) days in advance of work and maintained throughout the duration of the work. The Contractor shall notify the City of Raleigh regarding conflicting permanent signs. Only City of Raleigh forces shall install, remove or relocate any permanent signs within the right-of-way. All construction signs and barricades shall remain in place until the appropriate permanent signs and pavement markings are installed.

PEDESTRIAN CONSIDERATIONS

The Contractor shall accommodate the needs of all pedestrians in accordance with Section 1101-15 of the 2024 NCDOT Standard Specification for Roads and Structures.

EQUIPMENT AND MATERIAL STORAGE

During periods of construction inactivity, all construction materials and equipment shall be stored by the Contractor as specified in Section 1101-8, of the NCDOT Standard Specification for Roads and Structures

TRAFFIC SIGNALS

The City of Raleigh will furnish, erect, operate, maintain, relocate and remove all traffic signal equipment on the Project as necessary in accordance with the Project plans and specifications. The Contractor shall notify the Transportation Manager of RDOT at least 30 days prior to the installation, relocation or removal of traffic signal equipment on the Project. The Contractor shall not disturb any traffic signal equipment unless otherwise noted on the traffic control plans or directed to do so by the Engineer.

EXCAVATION AND TRENCHES

Excavations and trenches that cannot be properly backfilled and patched prior to the end of the workday shall be secured as specified in 2024 NCDOT Standard Specification for Roads and Structures.

MEASUREMENT

There will be no separate measurement made for Traffic Control.

PAYMENT

Traffic Control will be paid at the lump sum price for "Traffic Control." This payment will be full compensation for all elements of work required to complete the Project as specified.

Partial payments will be made as follows:

25% of the lump sum price on the first partial payment estimate made after any work has been performed on the item of “Traffic Control.”

25% of the lump sum price on the first partial payment after work is 25% complete.

25% of the lump sum price on the first partial payment after work is 50% complete.

25% of the lump sum price on the first partial payment after work is 100% complete.

Payment will be made under:

Pay Item

Pay Unit

Traffic Control

Lump Sum

SP-02 SHOTCRETE REPAIRS

(11-30-23)

GENERAL

The work covered by this Special Provision consists of removing deteriorated concrete from the structure in accordance with the limits, depth and details shown on the plans, described herein and as established by the Engineer. This work also includes removing and disposing all loose debris, cleaning and repairing reinforcing steel and applying structural shotcrete.

The location and extent of repairs shown on the plans are general in nature. The Engineer shall determine the extent of removal in the field based on an evaluation of the condition of the exposed surfaces.

Any portion of the structure that is damaged from construction operations shall be repaired to the Engineer's satisfaction, at no extra cost to the Department.

MATERIAL REQUIREMENTS

Use prepackaged dry mix shotcrete conforming to the requirements of ASTM C1480, the applicable sections of the *Standard Specifications* and the following:

Test Description	Test Method	Age (Days)	Specified Requirements
Silica Fume (%)	ASTM C1240	-	10 (Max.)
Air Content - As Shot (%)	ASTM C231 or ASTM C457	-	5 ± 2
Minimum Compressive Strength (psi)	ASTM C109	7	3,000
		28	5,000
Minimum Bond Pull-off Strength (psi)	ASTM C1583 or ASTM C882	28	250
Rapid Chloride Permeability Tests (range in coulombs)	ASTM C1202	-	100 – 1,000

Admixtures are not allowed unless approved by the Engineer. Store shotcrete in an environment where temperatures remain above 40°F and less than 95°F

All equipment must operate in accordance with the manufacturer's specifications and material must be placed within the recommended time.

QUALITY CONTROL

Qualification of Shotcrete Contractor

- A. The shotcrete Contractor shall provide proof of experience by submitting a description of jobs similar in size and character that have been completed within the last five (5) years. The name, address and telephone number of references for the submitted projects shall also be furnished. Failure to provide appropriate documentation will result in the rejection of the proposed shotcrete contractor.
- B. Qualification of Nozzleman
The shotcrete Contractor's nozzleman shall be certified by the American Concrete Institute (ACI). Submit proof of certification to the Engineer prior to beginning repair work. The nozzleman shall maintain certification at all times while work is being performed for the Department. Failure to provide and maintain certification will result in the rejection of the proposed nozzleman.

TEMPORARY WORK PLATFORM

Prior to beginning any repair work, provide details for a sufficiently sized temporary work platform at each repair location. Design steel members to meet the requirements of the American Institute of Steel Construction Manual. Design timber members in accordance with the *National Design Specification for Stress-Grade Lumber and Its Fastenings* of the National Forest Products Association. Submit the platform design and plans for review and approval. The design and plans shall be sealed and signed by a North Carolina registered Professional Engineer. Do not install the platform until the design and plans are approved. Drilling holes in the superstructure for the purpose of attaching the platform is prohibited. Upon completion of work, remove all anchorages in the substructure and repair the substructure at no additional cost to the Department.

SURFACE PREPARATION

Prior to starting the repair operation, delineate all surfaces and areas assumed to be deteriorated by visually examining and sounding the concrete surface with a hammer or other approved method. The Engineer is the sole judge in determining the limits of deterioration.

Prior to removal, introduce a shallow saw cut approximately ½" in depth around the repair area at right angles to the concrete surface. Remove all deteriorated concrete 1 inch below the reinforcing steel with a 17 lb (maximum) pneumatic hammer with points that do not exceed the width of the shank or with hand picks or chisels as directed by the Engineer. Do not cut or remove the existing reinforcing steel. Unless specifically directed by the Engineer, do not remove concrete deeper than 1 inch below the reinforcing steel.

Abrasive blast all exposed concrete surfaces and existing reinforcing steel in repair areas to remove all debris, loose concrete, loose mortar, rust, scale, etc. After sandblasting examine the reinforcing steel to ensure at least 90% of the original diameter remains. If there is more than 10% reduction in the rebar diameter, splice in and securely tie supplemental reinforcing bars as directed by the Engineer.

Provide stainless welded wire fabric at each repair area larger than one square foot if the depth of the repair exceeds 2 inches from the existing, intact exterior face of the concrete member. Provide a minimum 4" x 4" - 12 gage stainless welded wire fabric unless otherwise shown on the plans. Rigidly secure the welded wire fabric to existing steel or to $\frac{3}{16}$ " diameter stainless hook fasteners adequately spaced to prevent sagging. Encase the welded wire fabric in shotcrete a minimum depth of 1½ inches.

With the exception of overhead applications, the contractor has the option to use synthetic fiber reinforcement as an alternate to welded wire fabric if attaching welded wire fabric is impractical or if approved by the Engineer. Welded wire fabric and synthetic fiber reinforcement shall not be used in the same repair area.

Thoroughly clean the repair area of all dirt, grease, oil or foreign matter, and remove all loose or weakened material before applying shotcrete. Saturate the repair area with clean water the day before applying shotcrete. Bring the wetted surface to a saturated surface dry (SSD) condition prior to applying shotcrete and maintain this condition until the application begins. Use a blowpipe to facilitate removal of free surface water. Only oil-free compressed air is to be used in the blowpipe.

The time between removal of deteriorated concrete and applying shotcrete shall not exceed five (5) calendar days. If the time allowance exceeds (5) calendar days, prepare the surface at the direction of the Engineer before applying shotcrete.

APPLICATION AND SURFACE FINISH

Apply shotcrete only when the surface temperature of the repair area is greater than 40°F and less than 95°F. Do not apply shotcrete to frosted surfaces. Maintain shotcrete at a minimum temperature of 40°F for three (3) calendar days after placement.

Apply shotcrete in layers. The properties of the applied shotcrete determine the proper thickness of each layer or lift.

The nozzleman should hold the nozzle three (3) to four (4) feet from the surface being covered in a position that ensures the shotcrete strikes at right angles to the surface being covered without excessive impact. The nozzleman shall maintain the water amount at a practicable minimum, so the mix properly adheres to the repair area. Water content should not become high enough to cause the mix to sag or fall from vertical or inclined surfaces, or to separate in horizontal layers.

Use shooting wires or guide strips that do not entrap rebound sand. Use guide wires to provide a positive means of checking the total thickness of the shotcrete applied. Remove the guide wires prior to the final finish coat.

To avoid leaving sand pockets in the shotcrete, blow or rake off sand that rebounds and does not fall clear of the work, or which collects in pockets in the work. Do not reuse rebound material in the work.

If a work stoppage longer than two (2) hours takes place on any shotcrete layer prior to the time it has been built up to required thickness, saturate the area with clean water and use a blowpipe as outlined previously, prior to continuing with the remaining shotcrete course. Do not apply shotcrete to a dry surface.

Finish all repaired areas, including chamfered edges, as close as practicable to their original dimensions and configuration, unless otherwise required to provide a minimum 2" of cover for reinforcing steel exposed during repair. If necessary to extend shotcrete repair material beyond the original member dimensions and geometry, coordinate with the Engineer to determine methods, geometry, and dimensions of the final finished surface to provide a minimum 2" of cover on reinforcing steel. Slightly build up and trim shotcrete to the final surface by cutting with the leading edge of a sharp trowel. Use a

rubber float to correct any imperfections. Limit work on the finished surface to correcting imperfections caused by trowel cutting.

Immediately after bringing shotcrete surfaces to final thickness, thoroughly check for sags, bridging, and other deficiencies. Repair any imperfections at the direction of the Engineer.

Cure the completed shotcrete surface in accordance with Article 420-15(B) Water Method of the *Standard Specifications* for seven (7) calendar days. If the water method is impracticable and if approved by the Engineer, a membrane curing compound may be used in accordance with Subarticle 420-15(C) of the *Standard Specifications* at double the manufacturer's recommended coverage rate.

MATERIAL TESTING & ACCEPTANCE

Each day shotcreting takes place, the nozzleman shall shoot one 18" x 18" x 3.5" test panel in the same position as the repair work that is being done to demonstrate the shotcrete is being applied properly. Store, handle and cure the test panel in the same manner as the repaired substructure and do not disturb for the first 24 hours after shotcreting.

Approximately 72 hours after completing the final shotcrete placement, thoroughly test the surface with a hammer. At this time, the repair area should have sufficient strength for all sound sections to ring sharply. Remove and replace any unsound portions prior to the final inspection of the work. No additional compensation will be provided for removal and replacement of unsound shotcrete.

In accordance with Subarticle 1002-3(H) of the *Standard Specifications*, core three (3) 3" diameter samples from each test panel. Compressive strength values on test panels shall equal or exceed the required 28-day strength requirements. Should failures occur on the test panel cores, acceptance of the material will be determined by tests on cores from the installed work on the structure. A minimum of (3) three cores shall be taken from the area in question of the structure. The average compressive strength of the cores taken from the structure shall equal or exceed the specified strength of the shotcrete applied, and no single core shall have strength less than 85% of the specified value. Any cores taken from the structure shall penetrate into the existing concrete at least two (2) inches. Cores shall also be inspected for delamination, sand pockets, segregation, and voids.

The adequacy of the bond between the existing concrete and the shotcrete shall be determined by direct tension bond testing, in accordance with ASTM C1583 or ASTM C882, as directed by the Engineer. A minimum bond strength of 250 psi will be accepted as satisfactory. Bond failure less than 250 psi attributable to the failure of existing concrete will not be cause for rejection. The cost of up to three passing direct tension bond tests shall be the responsibility of the Contractor; additional passing pull-off tests will be the responsibility of the Department.

Any repair work failing to meet the requirements of this Special Provision will be rejected and the Contractor shall implement a remediation plan to correct the deficiency at no additional cost to the Department. No extra payment will be provided for drilling extra cores. Patch all core holes in the repaired structure to the satisfaction of the Engineer.

MEASUREMENT AND PAYMENT

Shotcrete Repairs will be measured and paid for at the contract unit price bid per cubic foot and will be full compensation for removal, containment and disposal off-site of unsound concrete including the cost of materials, labor, tools, equipment and incidentals necessary to complete the repair work. Depth will be measured from the original outside concrete face. If modifications to the dimensions and geometry are approved by the Engineer to achieve proper clearance over reinforcing steel, depth measurements will be made from the modified final outside face. The Contractor and Engineer will measure quantities after removal of unsound concrete and before application of repair material. Payment will also include the cost of sandblasting, surface cleaning and preparation, cleaning of reinforcing steel, placement of new steel, cost of temporary work platform, testing for soundness and bond strength, curing of shotcrete and taking core samples from the test panels and the structure.

Payment will be made under:

Pay Item	Pay Unit
Shotcrete Repairs (Superstructure)	Square Feet
Shotcrete Repairs (Substructure)	Square Feet

SP-03 CONCRETE REPAIRS (EPOXY COATING)

GENERAL

The work covered by this Special Provision consists of preparing the concrete surface and applying epoxy protective coating in accordance with the limits and details shown on the plans described herein and as established by the Engineer. This work also includes removing and disposing all loose debris, cleaning reinforcing steel and applying epoxy coating.

The location and extent of repairs shown on the plans are general in nature. The Engineer shall determine the extent of removal in the field based on an evaluation of the condition of the exposed surfaces.

MATERIAL PROPERTIES

Use an epoxy coating system that meet the requirements of 2024 NCDOT Standard Specifications for Roads and Structures, Section 420-18. Waterproof epoxy conforming to the following requirements

Color	Gray
Bond Strength, 14 Days, min.	1500 psi
Tensile Strength, 7 Days, min.	2000 psi

SURFACE PREPARATION

Prior to the application of epoxy coating material, thoroughly clean surfaces to be repaired and remove all loose materials. Remove grease, wax, and oil contaminants by scrubbing with an industrial grade detergent or degreasing compound followed by a mechanical cleaning. Remove weak or deteriorated concrete to sound concrete by bush hammering, grit-blasting, scarifying, water-blasting, or other approved methods. Remove dirt, dust, laitance and curing compounds by grit-blasting, sanding, or etching with 15% hydrochloric acid.

APPLICATION

When surface preparation is completed, apply epoxy coating to the areas specified in the contract plans and established by the Engineer.

Apply epoxy protective coating per manufactures recommendations.

After applying the epoxy coating, remove excessive material and provide a smooth, flush surface.

Remove the epoxy material in accordance with the supplier's instructions.

MEASUREMENT AND PAYMENT

Concrete Repairs (Epoxy Coating) will be paid at the contract unit price per square foot. Such payment will be full compensation for furnishing all material, labor, tools and equipment necessary for performing this work complete in place and accepted. For repairs of edge or corner areas, the surface to be measured for payment will be the largest surface and the other surfaces will not be measured.

Payment will be made under:

Pay Item	Pay Unit
Concrete Repairs (Epoxy Coating)	Square Feet

SP-04, POLYMER MODIFIED ASPHALT EXPANSION JOINT

SCOPE OF WORK

This work shall consist of supplying and installing a binder and aggregate system composed of specially blended polymer modified asphalt and specific aggregate placed in layers into a prepared expansion joint block-out. When properly installed, the asphaltic plug joint will provide a flexible waterproof bridge joint, which will allow for a joint movement of 1" in expansion and 1" in compression.

SUBMITTAL

Submit the product documentation for the asphalt plug joint being used to the Engineer for acceptance two weeks prior to starting the work. Include in the submittal,

- a) Product Specifications
- b) Material Safety Data Sheet
- c) Manufacturer's Recommended Application Procedure
- d) Contractor's Work Plan for Installing Joint.

Do not install the joint until authorization is received from the Engineer.

MATERIALS

1. Binder

The bridge joint binder shall be a polymer modified asphalt, as manufactured by and shall meet the following requirements of Table 1 when tested according to ASTM testing methods.

Table 1		
Binder Properties		
	Test Method	Typical Values
Softening Point	ASTM D-36	180° F (82° C)
Tensile Adhesion	ASTM D-3583	750% Min.
Ductility @ 77° F (25° C)	ASTM D-113	40 cm. Min.
Penetration	ASTM D-3407	
	77° F (25° C) 150g, 5 Sec	90 dmm Max.

	0° F (-18° C) 200g, 60 Sec	10 dmm Min.
Flow 5H @ 140° F (60° C)	ASTM D-3407	3.0 mm Max.
Resilience @ 77° F (25° C)	ASTM D-3407	40% Min.
Asphalt Compatibility	ASTM D-3407	Pass
Recommended Pouring Temp.		140° F (60° C)
Safe Heating Temp.		140° F (60° C)

2. Aggregate

The stone type shall consist of granite, basalt, gabbro, porphyry or gritstones. The specified aggregate shall be crushed, double washed and shall meet the following requirements in Table 2.

Table 2	
Gradation	
Seive Size	Percent Passing
7/8"	95-100
5/8"	30-50
1/2"	30-Oct
3/8"	0-7
1/4"	-
#8	-

3. Backer Rod

The backer rod shall be a closed cell, foam expansion joint filler, capable of withstanding the elevated temperature of the polymeric binder. The backer rod shall have the following typical physical properties using a 2" specimen and test method ASTM D-545:

Table 3	
Backer Rod Properties	
Density	2.0 lbs/cu. Ft. min.
Tensile Strength	30 psi min.
Compression	5 psi @ 25% min.
Water Absorbtion	.03 g/cc by weight, min.
Temperature @ 410° F (210° C)	No Melting

4. Bridging Plate

The bridging plate shall be a mild steel plate, ¼” thick by 8” wide, cut in 4’ to 5’ lengths. Spike holes shall be drilled on a longitudinal centerline at 1’ intervals.

INSTALLATION CREW

The asphaltic plug joint is to be installed only by factory trained and certified installation professionals with documented training.

EQUIPMENT

The equipment will consist of:

1. Small self-propelled dry cut saw
2. Pneumatic compressor of 185 CFM capacity.
3. One Hot-Compressed Air Lance (HCA Lance), capable of delivering flame retarded air stream with a temperature of 3,000° F (1648° C), at a speed of 3,000 feet per second.
4. Rotating vented or un-vented drum type mixers each with a Hot-Compressed Air Lance (HCA Lance), or a pressure – air injection torch (PAT torch).
5. Melter unit equipped with agitation and an automatic temperature control which can accurately maintain the material temperature from 100°F - 650°F (38°C - 343°C). A thermometer to monitor the material temperature must be provided. The burner system shall have a safety pilot capable of shutting off the gas supply in the event of a flame-out.
6. 100 lb. Bottles of propane or smaller
7. Vibratory roller or plate capable of compacting up to 1” in one pass.
8. Handheld calibrated digital temperature sensor.
9. Chop-saw with carbide blade, if needed.
10. Sandblasting equipment, required only for installation in a concrete overlay.
11. Safety clothing and equipment as required by OSHA.

INSTALLATION

The following procedures are to be followed to ensure a successful installation:

Note: The asphaltic plug joint must be installed at a minimum depth of two inches (2”).

1. **Marking out:** The asphaltic plug joint shall be located centrally over the deck expansion gap or fixed joint and marked out to the recommended minimum width of 20”.
2. **Excavation:** The joint shall be excavated by the use of saws and pneumatic hand tools. Where possible, saws shall be set to cut the full required depth of the wearing surface and any membrane present. Variations in the depth of the wearing surface across the road should be considered to insure, where possible, that the deck is not damaged. All debris from the excavation channel shall be removed to allow the full volume of new joint to be installed.
3. **Cleaning:** The entire channel must be thoroughly cleaned and dried. Small debris will be removed by using compressed air. The Hot Compressed Air Lance will then be applied throughout the length of the channel.

Installation in concrete overlays requires sandblasting of the concrete vertical walls and adjacent deck area prior to the use of the HCA Lance application.

Clean the joints by sandblasting with clean dry sand immediately before placing the bonding agent. Sandblast the joint opening to provide a firm, clean joint surface free of curing compound, loose material and any foreign matter. Sandblast the joint opening without causing pitting or uneven surfaces. The aggregate in the elastomeric concrete may be exposed after sandblasting.

After blasting, either brush the surface with clean brushes made of hair, bristle or fiber, blow the surface with compressed air, or vacuum the surface until all traces of blast products and abrasives are removed from the surface.

If nozzle blasting is used to clean the joint opening, use compressed air that does not contain detrimental amounts of water or oil.

4. **Repairs:** Spalled and defective concrete should be repaired with an approved material as agreed upon by the Project Engineer.
5. **Caulking:** The gap shall be caulked with the backer rod, allowing for approximately 1” of binder in the gap on top of the rod. If the previous caulking is intact and will hold the binder, it may be used to take the place of the backer rod. A small amount of hot binder should be placed onto the caulking to insure that the gap is adequately plugged.
6. **Tanking:** Immediately after cleaning and caulking, the entire channel shall be coated with a thin layer of hot binder. If significant delay occurs, the channel shall be inspected to determine if re-cleaning is necessary.
7. **Plating:** The gap shall be bridged with the steel plates centered over the gap by placing locating pins in the centerline of the plate. There must be at least 2” between the edge of the steel plate and the wall of the channel. Once the locating pins are in place, the top of the plate shall be coated with a thin layer of hot binder.

MATERIAL PREPARATION

Aggregate: The aggregate must be heated in a vented or un-vented rotating drum mixer by the use of a hot compressed air lance (HCA Lance), or a pressure air injection torch (PAT torch). Once the aggregate has been heated to a temperature of 370° - 380° F (188° - 193° C), it is then coated with a small quantity of binder. One gallon of binder per 100 lbs. of stone should be sufficient to coat the stone.

Binder: The binder shall be heated to the recommended pouring temperature, 370° - 385° F (188° - 196°C). At no time shall the recommended safe heating temperature of 400° F (204° C) be exceeded. Material Installation: Layers of hot pre-coated aggregate not more than 2.5" thick shall be placed in the channel and immediately covered to the level of the coated aggregate. This will ensure that the 3:1 weight ratio of aggregate to binder has been achieved. Layers shall be raked to insure the aggregate is completely coated and that all air pockets are eliminated. This process shall cease approximately three-quarters of an inch (3/4") from the top of the channel.

Surface Layer: The surface layer shall be applied as other layers except that the pre-coated aggregate is not flooded with binder. The pre-coated aggregate shall be transferred to the joint and leveled slightly higher than the adjacent road surface. On a standard 2" deep joint, the topcoat should be one quarter inch (1/4") higher than the road surface. Deeper joints will require higher levels before tamping.

Compaction: Compaction should take place after the joint has cooled to approximately 225° F (107° C). The joint surface shall be made approximately level with the existing road surface by using the vibratory plate or roller.

Top Coating: After compaction, lines of 4" tape are placed one inch beyond the joint width on each side of the joint to insure evenness of appearance. The joint and at least one inch of the road surface shall be top-coated with the hot binder until the surface is smooth and absent of voids. Note: If it is impossible to topcoat the joint during the same working day/night, it is allowable that the topcoat step be completed on the next working day/night. However, the surface must be cleaned, dried, and heated with the HCA Lance.

Surface Dressing: Immediately after top-coating, an anti-skid material is spread evenly over the joint to eliminate material tracking (Black Beauty Sand, Medium Grade). Final Preparation: Prior to departure the crew will insure that the entire work area is clean of debris.

Temporary Joint: In the event of a work stoppage while constructing a joint, the following procedure can be used for low ADT roadways (<20,000). Fill the cavity with cold uncoated aggregate to the level of the road surface and top the aggregate with binder to form a temporary riding surface. Roadways with an ADT greater than 20,000 will require materials similar to a cold patch asphalt. Be sure whatever is used is approved by the state agency.

Quality Control

Upon request, certifications of the materials will be provided.

The Engineer may require the contractor to provide samples during the course of the work for laboratory test of any or all of the properties specified.

MEASUREMENT AND PAYMENT

Asphalt Plug Joint @ "X" will be paid at the contract unit price per lineal feet. Such payment will be full compensation for furnishing all material, labor, tools and equipment necessary for Prices and payment will be full compensation for furnishing all material, labor, tools, equipment, and incidentals necessary for installing these units in place and accepted.

Payment will be made under:

Pay Item	Pay Unit
Asphalt Plug Joint @ 5"	Lineal Feet

SP-05, PAINTING EXISTING STEEL STRUCTURE

(11-30-23)

GENERAL

This work shall consist of furnishing all labor, equipment, and materials necessary to clean and paint the ends of the weathering steel girders, zones of excessive corrosion, bent diaphragms, all bearing plates, anchor bolts, nuts, and washers of the existing structure. Work includes: removal, containment and disposal of the existing paint system; preparation of the surface to be painted and applying the new paint system; a containment enclosure; and any incidentals necessary to complete the project as specified and shown on the plans.

SCOPE OF WORK

Bridge #911453: This bridge was built in 2018 and carries Angel Falls Rd. The structure is structural plate arch. The bridge has an overall length of 20'-0" and a 98'-6" total length along the centerline of the pipe. The existing paint system is galvanized steel, and the estimated area to be cleaned and painted is **600** sq. ft.

Bridge #911456: This bridge was built in 2018 and carries Angel Falls Rd. The structure is structural plate arch. The bridge has an overall length of 22'-0" and a 70' total length along the centerline of the pipe. The existing paint system is galvanized steel, and the estimated area to be cleaned and painted is **560** sq. ft.

TWELVE-MONTH OBSERVATION PERIOD

The Contractor maintains responsibility for the coating system for a 12-month observation period beginning upon the satisfactory completion of all the work required in the plans or as directed by the Engineer. The Contractor shall guarantee the coating system under the payment and performance bond (refer to Article 103-7 of the *Standard Specifications*). To successfully complete the observation period, the coating system shall meet the following requirements after 12 months service:

- (A) No visible rust, contamination or application defect is observed in any coated area.
- (B) Painted surfaces have a uniform color and gloss.
- (C) Painted surfaces have an adhesion that meets an ASTM D3359, 3A rating.

Final acceptance is made only after the paint system meets the above requirements.

SUBMITTALS

Submit all of the following to the Engineer for review and approval before scheduling the pre-construction meeting. Allow at least two (2) weeks for the review process.

- (A) The existing paint systems include toxic substances such as red lead oxide, which are considered hazardous if improperly removed. The contractor shall be currently certified for Society for Protective Coatings (SSPC) Quality Program (QP) 2, Category A, and have successfully completed lead paint removal and field painting on similar structures within 18 months prior to this bid. Lead abatement work completed within the 18 month period shall have been completed in accordance with contract specifications, free of citation from safety or environmental agencies. Lead abatement work shall include, but not be limited to: abrasive blasting; waste handling, storage and disposal; worker safety during lead abatement activities (fall protection, personal protective equipment (PPE), etc.); and containment. This requirement is in addition to the contractor pre-qualification requirements covered by Article 102-2 of the *Standard Specifications*.
The apparent low bidder shall submit a list of projects for which QP 2 work was performed within the last 18 months including owner contact information and submit to the Engineer a "Lead Abatement Affidavit". This form may be downloaded from: <https://www.ncdot.gov/initiatives-policies/Transportation/bridges/Documents/leadabatementaffidavit.pdf>
- (B) Work schedule which shall be kept up to date, with a copy of the revised schedule being provided to the Engineer in a timely manner.
- (C) Containment system plans and design calculations in accordance with SSPC Guide 6, Class 3A and other project requirements, signed and sealed by a Professional Engineer licensed by the State of North Carolina.
- (D) Bridge wash water sampling and disposal plan.
- (E) Subcontractor identification.
- (F) Lighting plan for night work in accordance with Section 1413 of the *Standard Specifications*.
- (G) Traffic control plan with NCDOT certified supervisors, flaggers and traffic control devices.
- (H) Health and safety plan addressing at least the required topics as specified by the SSPC QP 1 and QP 2 program and including hazard communication, respiratory health, emergency procedures, and local hospital and treatment facilities with directions and phone numbers, disciplinary criteria for workers who violate the plan and accident investigation. The plan shall address the following: hazardous materials, personal protective equipment, general health and safety, occupational health and environmental controls, fire protection and prevention, signs signals, and barricades, materials handling, storage, use, and disposal, hand and power tools, welding and cutting, electrical, scaffolds, fall protection, cranes, derricks, hoists, elevators, and conveyors, ladders, toxic and hazardous substances, airless injection and high pressure water jet (HPWJ).

- (I) Provide the Engineer a letter of certification that all employees performing work on the project have blood lead levels that are below the Occupational Safety and Health Administration (OSHA) action level.
- (J) Provide the Engineer with Competent Person qualifications and summary of work experience.
- (K) Environmental Compliance Plan.
- (L) Quality Control Plan (Project Specific) with quality control qualifications and summary of work experience.
- (M) Bridge and Public Protection Plan (Overspray, Utilities, etc. - Project/Task Specific).
- (N) Abrasive Blast Media:
 - (1) Product Data Sheet.
 - (2) Blast Media Test Reports in accordance with Article 442-4 of the *Standard Specification*.
- (O) Coating Material:
 - (1) NCDOT HICAMS Test Reports (testing performed by NCDOT Materials and Tests Unit).
 - (2) Product Data Sheets.
 - (3) Material Safety Data Sheets.
 - (4) Product Specific Repair Procedures.
 - (5) Acceptance letters from paint manufacturer's for work practices that conflict with Special Provisions and/or paint manufactures product data sheets.

PRE-CONSTRUCTION MEETING

Submittals shall be reviewed and approved by the Engineer prior to scheduling the pre-construction meeting. Allow no less than two (2) weeks for a review process. When requesting a pre-construction meeting, contact the Engineer at least seven (7) working days in advance of the desired pre-construction date. The contractor's project supervisor, Competent Person, quality control personnel and certified traffic control supervisor shall attend the pre-construction meeting in order for the Contractor and NCDOT team to establish responsibilities for various personnel during project duration and to establish realistic timeframes for problem escalation.

CONTAINMENT SYSTEM

Prior to performing any construction or painting operations on the structure, the Contractor shall furnish the Engineer with plans and design calculations for a sufficiently designed containment system, which will provide access for any repairs on structural steel members, cleaning and surface preparations for structural steel members, and coating operations for structural steel members of

the bridge. The containment system shall not be installed, and no work shall begin, until the Engineer has reviewed and approved, in writing, the submitted containment system plans and design calculations. Containment system plans and design calculations shall be prepared, sealed, and signed by a Professional Engineer licensed by the State of North Carolina. Allow a minimum of two (2) weeks for review of the containment plans and calculations.

The containment system shall meet or exceed the requirements of Class 3A containment in accordance with SSPC Guide 6. The Contractor shall determine the required capacity of the containment system, which, at a minimum, shall include loads due to wind, repair materials and repair operations, equipment, and tools; however, the capacity shall not be less than that required by Federal or State regulations. Design steel members to meet the requirements of the *American Institute of Steel Construction Manual*. Design timber members in accordance with the *National Design Specification for Stress-Grade Lumber and Its Fastenings* of the National Forest Products Association. The containment system shall be constructed of materials capable of withstanding damage from any of the work required on this project and shall provide a two (2) hour resistance to fire.

In the containment system plans, describe how debris is contained and collected. Describe the type of tarpaulin, bracing materials, and the maximum designed wind load. Design wind loads shall be in accordance with the Falsework and Formwork Special Provision. Describe the dust collection system and how a negative pressure of 0.03 inches of water column is maintained inside the enclosure, while blasting operations are being conducted. Describe how the airflow inside the containment structure is designed to meet all applicable OSHA Standards. Describe how water run-off from rain will be routed by or through the enclosure. Describe how wash water will be contained and paint chips separated. Describe what physical containment will be provided during painting application to protect the public and areas not to be painted.

Drilling holes in the superstructure for the purpose of attaching the containment system is prohibited.

The Contractor will be responsible for certifying the containment system has been constructed in accordance with the approved plans.

The containment system shall be cleaned after each workday.

Upon completion of work, remove all anchorages in the substructure and repair the substructure at no additional cost to the Department.

Protect non-metallic parts of bearings from blasting and painting (i.e.: Pot Bearings, Elastomeric Pads, and Disc Bearings).

WASH WATER SAMPLING AND DISPOSAL PLAN

All wash water shall be collected and sampled prior to disposal. Representative sampling and testing methodology shall conform to North Carolina Administrative Code 15A NCAC 02B.0103, "Analytical Procedures". Wash water shall be tested for pollutants listed in 15A NCAC 02B.0211(3), 15A NCAC 02T.0505(b)(1) and 15A NCAC 2T.0905(h). Depending

on the test results, wash water disposal methods shall be described in the disposal plan. Wash water shall be disposed of in accordance with all current Federal and State regulations. See link for NCDOT Guidelines for Managing Bridge Wash Water:

<https://www.ncdot.gov/initiatives-policies/Transportation/bridges/Documents/WashWater.pdf>

WASTE HANDLING OF PAINT AND ABRASIVES

Comply with all Federal, State, and local regulations. Failure to comply with the regulations could result in fines and loss of qualified status with NCDOT.

Comply with the Resource Conservation and Recovery Act (RCRA - 40 CFR 261 - 265) and the Occupational Safety and Health Act (OSHA - 29 CFR 1910 - 1926) regulations for employee training, and for the handling, storage, labeling, recordkeeping, reporting, inspections and disposal of all hazardous waste generated during paint removal.

A summary of Generator Requirements is available at the following NCDOT web link, which cites the specific regulations for each Generator category:

<https://www.deq.nc.gov/waste-management/dwm/hw/guidance-document-table-documents/summary-generator-requirements-0/download?attachment>

No work shall begin until the Contractor furnishes the Engineer with a written waste disposal plan. Any alternative method for handling waste shall be pre-approved by the Engineer. Example guidance on Contractor's waste disposal plan content can be found in the information below:

<https://www.deq.nc.gov/waste-management/dwm/hw/guidance-document-table-documents/generator-category-guidance/download?attachment>

(A) Guidance for Small Quantity Generator (SQG) can be found at the following weblink:

<https://www.deq.nc.gov/waste-management/dwm/hw/guidance-document-table-documents/small-quantity-generator-checklist-0/download?attachment>

(B) Guidance for Large Quantity Generator (LQG) can be found at the following weblink:

<https://www.deq.nc.gov/environmental-management-commission/water-quality-committee-meetings/2018/large-quantity-generator-checklist/download>

The North Carolina Department of Environmental Quality (NCDEQ) adopted the federal provisions of RCRA in the North Carolina Hazardous Waste Management Rules (15A NCAC 13A) and is responsible for the administration and enforcement of these rules. The *Hazardous Waste Generator Compliance Manual* created by the NCDEQ, Division of Waste Management, Hazardous Waste Section, Compliance Branch can be found at:

<https://www.deq.nc.gov/waste-management/dwm/hw/guidance-document-table-documents/hazardous-waste-generator-compliance-manual/download?attachment>

Immediately after awarding the contract, arrange for waste containers, sampling, testing, transportation, and disposal of all waste. Use an approved hazardous waste management company from the following link:

<https://www.ebs.nc.gov/VendorDirectory/results.html?sap-params=cD0xJTIwJmN1cnJlbnRfc2VhcmNoX3BhZ2U9d2Mmc2VsZWNoaW9uX2Zpcm1f>

[bmFtZT0mc2VsZWNoaW9uX2NlcnQ9JnNlbGVjdGlvb19maXJtdHlwZT0meXNjX2Zpcm10eXBIPSZzZWxlY3Rpb25fd29ya2xvY2F0aW9uPSZ5c2Nfd29ya2xvY2F0aW9uPSZzZWxlY3Rpb25fYWRkcnN0YXRIPSZ5c2NfYWRkcnN0YXRIPSZzZWxlY3Rpb25fYWRkcmNvdW50eT0meXNjX2FkZHIjb3VudHk9JnNlbGVjdGlvb193a2NvZGU9MDAzMDQwJnlzY193a2NvZGU9MDAzMDQwJTIwQ09OVEFNSU5BVEVEJTIwTUFURVJQUxTJTIwUkVN T1ZBTCZzZWxlY3Rpb25fZGlzYz0meXNjX2Rpc2M9JnNlbGVjdGlvb19uYWljcz0meXNjX25haWNzPSZzZWxlY3Rpb25fY3R5cGU9MA%3d%3d](https://www.deq.nc.gov/water-quality/planning/tmdl/303d/2020/lead-based-paint-waste-guidance/download)

All removed paint and spent abrasive media shall be tested for lead following the SW-846 Toxicity Characteristic Leaching Procedure (TCLP) Method 1311 Extraction, as incorporated by reference in 40 CFR 260.11, to determine whether it shall be disposed of as hazardous waste. Furnish the Engineer with certified test reports showing TCLP results of the paint waste accumulated on site, in accordance with “Lead-Based Paint Waste Guidance” at:

<https://www.deq.nc.gov/water-quality/planning/tmdl/303d/2020/lead-based-paint-waste-guidance/download>

(C) Toxicity characteristic 40 CFR 261.24

<https://www.ecfr.gov/current/title-40/chapter-I/subchapter-I/part-261/subpart-C/section-261.24>

(D) Analytical Methods for Characteristic Hazardous Waste Determination

<https://www.deq.nc.gov/waste-determination-test-method/download?attachment>

All sampling shall be performed in the presence of the Engineer’s representative.

The Competent Person shall obtain composite samples from each barrel of the wash water and waste generated by collecting two or more portions taken at regularly spaced intervals during accumulation. Composite the portions into one sample for testing purposes. Acquire samples after 10% or before 90% of the barrel has accumulated. The intent is to provide samples that are representative of widely separated portions, but not the beginning and end of wash water or waste accumulation.

Perform sampling by passing a receptacle completely through the discharge stream or by completely diverting the discharge into a sample container. If discharge of the wash water or waste is too rapid to divert the complete discharge stream, discharge into a container or transportation unit sufficiently large to accommodate the flow and then accomplish the sampling in the same manner as described above.

Comply with the NCDEQ Hazardous Waste Compliance Manual. Record quantities of waste by weight and dates of waste generation. Waste accumulated at the project site shall be properly labeled. Until test results are received, accumulate all waste, and label as “NCDOT Bridge Paint Removal Waste – Hazardous Waste Pending Analysis” and include the date generated and contact information for the Engineer. Accumulate waste containers in an enclosed, sealed, and secured storage container protected from traffic from all directions. Obtain approval for the protection plan for these containers from the Engineer. If adequate protection cannot be obtained by use of existing

guardrail, provide the necessary supplies and equipment to maintain adequate protection. The NCDEQ Hazardous Waste Compliance Manual can be found at:

<https://www.deq.nc.gov/waste-management/dwm/hw/guidance-document-table-documents/hazardous-waste-generator-compliance-manual/download?attachment>

Once test results are received and waste is characterized, label waste as either “Hazardous Waste - Pending Disposal” (for hazardous waste) or “Paint Waste - Pending Disposal” (for non-hazardous waste). All waste, hazardous or non-hazardous, requires numbered shipping manifests and/or equivalent material accountability.

Once the waste has been collected, and the quantities determined, prepare the appropriate shipping documents and manifests, and present them to the Engineer.

As of October 1, 2019, "Provisional ID Numbers" (starting with the prefix "NCP") are no longer issued by the North Carolina Hazardous Waste Section. EPA Identification (ID) Numbers are now issued for sites operating as "Short Term Generators."

(E) Short Term Generator Guidance:

<https://files.nc.gov/ncdeq/Waste%20Management/DWM/HW/8700-guidelines/Short-Term-Generators.pdf>

For questions about Short Term Generator Notification:

Andrew Minter: Administration Specialist
Hazardous Waste Section
Phone: 919-707-8265
Email: Andrew.Minter@deq.nc.gov

Laura Alexander: Business Officer
Hazardous Waste Section
Phone: 919-707-8214
Email: Laura.Alexander@deq.nc.gov

The Engineer will verify the type and quantity of hazardous waste and obtain an EPA ID number (for new sites) or update an existing EPA ID number electronically using the EPA’s RCRAInfo database:

<https://rcrainfo.epa.gov/rcrainfoprod/action/secured/login>

(F) Link to Quick Reference Guide for RCRAInfo Registration and Notification Submittal

<https://www.deq.nc.gov/waste-management/dwm/hw/8700-guidelines/quick-reference-guide-rcrainfo-registration-and-notification/download?attachment>

(G) Link to the more comprehensive RCRAInfo Registration and Notification Tutorial

<https://www.deq.nc.gov/waste-management/dwm/hw/hw-guidelines/rcrainfo-registration-and-electronic-notification-tutorial/download?attachment>

The hazardous waste fee will be assessed at the time the short-term EPA ID number is requested and must be paid prior to the EPA ID number being issued. When completing the RCRAInfo notification, the Hazardous Waste Section requires a valid email address for the site contact since this is the person who will be contacted to pay the fee. NOTE: The cost for waste disposal

(including lab and Short-Term Generator EPA ID number) shall be included in the bid price for this contract. At the time of shipping, the Engineer will ensure the proper EPA ID number has been entered in Box 1 of the manifest as well as sign and date the manifest. The maximum on-site accumulation time shall be **90 calendar days**. All waste, whether hazardous or non-hazardous will require numbered shipping manifests. The cost for waste disposal (including lab and Short-Term Generator EPA ID number) shall be included in the bid price for this contract.

If you have site specific questions, please contact your local Hazardous Waste Section Inspector. Inspector contact information and regions are on the map at this link:

<https://www.deq.nc.gov/compliance-map-inspector/download?attachment?attachment>

Testing labs shall be certified in accordance with the National Lead Laboratory Accreditation Program (NLLAP) and/or the National Environmental Laboratory Accreditation Program (NELAP).

(H) A list of NLLAP certified laboratories may be obtained at:

<https://www.epa.gov/system/files/documents/2023-05/nllap.pdf>

(I) A list of NELAP certified laboratories may be obtained at:

<https://lams.nelac-institute.org/Search>

All test results shall be documented on the lab analysis as follows:

(J) For leachable lead:

(1) Soils/Solid/Liquid – EPA 1311/200.7/6010

Area sampling will be performed for the first two (2) days at each bridge location. The area sample will be located within five (5) feet of the containment and where the highest probability of leakage will occur (access door, etc.). Results from the area sampling will be given to the Engineer within 72 hours of sampling (excluding weekends). If the results of the samples exceed $20 \mu\text{g}/\text{m}^3$ corrective measures shall be taken and monitoring shall be continued until two (2) consecutive sample results are less than $20 \mu\text{g}/\text{m}^3$.

Time Weighted Average (TWA) may suspend the work if there are visible emissions outside the containment enclosure or pump monitoring results exceeding the level of $30 \mu\text{g}/\text{m}^3$.

Where schools, housing and/or buildings are within 500 feet of the containment, the Contractor shall perform initial Total Suspended Monitoring (TSP) Lead monitoring for the first ten (10) days of the project during abrasive blasting, vacuuming and containment removal. Additional monitoring will be required during abrasive blasting two (2) days per month thereafter. Results of the TSP monitoring at any location shall not exceed $1.5 \mu\text{g}/\text{m}^3$.

EQUIPMENT MOBILIZATION

The equipment used in any travel lanes and paved shoulder shall be mobile equipment on wheels that has the ability to move on/off the roadway in less than 30 minutes. All work conducted in travel lanes shall be from truck or trailer supported platforms and all equipment shall be self-propelled or attached to a tow vehicle at all times.

QUALITY CONTROL INSPECTOR

Provide a quality control (QC) inspector in accordance with the SSPC QP guidelines to ensure that all processes, preparation, blasting and coating application are in accordance with the requirements of the contract. The inspector shall have written authority to perform QC duties to include continuous improvement of all QC internal procedures. The presence of the engineer or inspector at the work site shall in no way lessen the contractor's responsibility for conformity with the contract.

QUALITY ASSURANCE INSPECTOR

The quality assurance inspector which may be a Department employee or a designated representative of the Department shall observe, document, assess, and report that the Contractor is complying with all of the requirements of the contract. Inspectors employed by the Department are authorized to inspect all work performed and materials furnished. Such inspection may extend to all or any part of the work and to the preparation, fabrication, or manufacture of the materials to be used. The inspector is not authorized to alter or waive the requirements of the contract. Each stage in preparing the structure to be coated which includes but not limited to washing, blasting, coating testing and inspection shall be inspected and approved by the Engineer or an authorized representative.

SUBLETTING OF CONTRACT

Only contractors certified to meet SSPC QP 2, Category A, and have successfully completed lead paint removal and field painting on all similar structures within 18 months prior to this bid are qualified for this work. Work is only sublet by approval of the Engineer.

LIMITS OF ZONE PAINTING

If any girder has excessive corrosion along its bottom flange, beyond the distance of 1.5 times the depth of the beam or girder, at the bearing, the area of the affected girder indicated on the plans, and other girders as directed by the Engineer, shall be cleaned in accordance with the requirements of System 5 painting system. The horizontal limits of zone painting shall extend 12" beyond the maximum horizontal extent of web/flange corrosion. The vertical limits of zone painting shall extend 3" beyond the maximum vertical extent of web corrosion.

Areas designated for zone coating shall be primed and coated in accordance with System 5 as outlined in Article 442-8 of the *Standard Specifications*.

System 5 is one coat of primer, one intermediate acrylic coat, one stripe coat of paint, and one topcoat of paint and over non-weathering steel surfaces cleaned to an SSPC SP-6 finish.

Painting shall be performed in accordance with Section 442 and Section 1080 of the *Standard Specifications*, and/ or these Special revisions; the more restrictive requirement shall apply. Perform all mixing operations over an impervious surface with provisions to prevent runoff to grade of any spilled material.

PREPARATION OF SURFACES

Before any other surface preparation is conducted, all surfaces shall be power washed to remove dust, salts, dirt, and other contaminants. All wash water shall be contained, collected, and tested in accordance with the requirements of NCDOT Guidelines for Managing Bridge Wash Water. Obtain approval of the Engineer and allow all cleaned surfaces to dry to the touch and without standing water before beginning surface preparation or painting activities.

Surface preparation is done with materials meeting Article 1080-12 of the *Standard Specifications*. No silica sand or other silica materials are permitted for use. The profile shall be between 1.0 and 3.0 mils when measured on a smooth steel surface. Conduct and document at least two (2) tests per beam/girder and two (2) tests per span of diaphragms/cross bracing.

Spread tarpaulins over all pavements and surfaces underneath equipment used for abrasive blasting as well as equipment and containers used to collect abrasive media. This requirement will be enforced during activity and inactivity of equipment.

Before the Contractor departs from the work site at the end of the workday, collect all debris generated during surface preparation and all dust collector hoses, tarps or other appurtenances containing blasting residue in approved containers.

Clean a 3" x 3" area at each structure to demonstrate the specified finish, and the inspector will preserve this area by covering it with tape, plastic or some other suitable means so that it can be retained as the Dry Film Thickness (DFT) gauge adjustment standard. An acceptable alternative is for the Contractor to provide a steel plate with similar properties and geometry as the substrate to be measured.

The contractor and or quality assurance representative shall notify the Engineer of any area of corroded steel that has lost more than 50% of its original thickness.

All parts of the bridges not to be painted and the travelling public shall be protected from overspray. Submit a plan to protect all parts of bridge that are not required to be painted and a plan to protect the traveling public and surrounding environment while applying all coats of paint to a structure.

Ensure that chloride levels on the surfaces are $7 \mu\text{g}/\text{cm}^2$ or lower using an acceptable sample method in accordance with SSPC Guide 15. The frequency of testing shall be two (2) tests per span after all surface preparation has been completed and immediately prior to painting. Select test

areas representing the greatest amount of corrosion in the span as determined by the Engineers' representative. Additional testing may be required if significant amounts of chloride are detected.

All weld splatter, slag or other surface defects resulting in a raised surface above the final paint layer shall be removed prior to application of primer coat.

PAINTING OF STEEL

Paint System 5, as specified in these Special Provisions and Article 442-8 of the *Standard Specifications*, is to be used for this work. System 5 is one coat of primer, one intermediate acrylic coat, one stripe coat of paint, and one topcoat of paint over non-weathering steel surfaces blast-cleaned surfaces in accordance with SSPC-SP-6 (Commercial Blasting). Perform all mixing operations over an impervious surface with provisions to prevent runoff to grade of any spilled material. The contractor is responsible for reporting quantities of thinner purchased as well the amounts used. No container with thinner shall be left uncovered, when not in use.

Apply 2" stripe coat, by brush or roller only, to all exposed edges of steel including fasteners before applying the finish coat. Locate the edge or corner in the approximate center of the paint stripe.

Any area where newly applied paint fails to meet the specifications shall be repaired or replaced by the Contractor, at no additional cost to the Department. The Engineer approves all repair processes before the repair is made. Repaired areas shall meet the *Standard Specifications*. The Contractor applies an additional finish coat of paint to areas where the tape adhesion test is conducted.

MATERIALS

Only paint suppliers that have a NCDOT qualified inorganic zinc primer may furnish paints for this project. All paints applied to a structure shall be from the same supplier. Before any paints are applied the Contractor shall provide the Engineer a manufacturer's certification that each batch of paint meets the requirements of the applicable Section 1080 of the *Standard Specifications*.

Color of the paint shall match that of the existing paint on the structure steel.

The inspector randomly collects a one-pint sample of each paint product used on the project. Additional samples may be collected as needed to verify compliance to the specifications.

Do not expose paint materials to rain, excessive condensation, long periods of direct sunlight, or temperatures above 110°F or below 40°F. In addition, the Contractor shall place a device that records the high, low, and current temperatures inside the storage location. Follow the manufacturer's storage requirements if more restrictive than the above requirements.

INSPECTION

Surface Preparation for System 5 shall be in accordance with SSPC SP-6. Any area(s) not meeting the requirements of SSPC SP-6 shall be remediated prior to application of coating. Surface inspection is considered ready for inspection when all blast abrasive, residue and dust is removed from surfaces to be coated.

(A) Quality Assurance Inspection

The Contractor furnishes all necessary OSHA approved apparatus such as ladders, scaffolds and platforms as required for the inspector to have reasonable and safe access to all parts of the work. The contractor illuminates the surfaces to be inspected to a minimum of 50-foot candles of light. All access points shall be illuminated to a minimum of 20-foot candles of light.

NCDOT reserves the right for ongoing Quality Assurance (QA) inspection to include but not limited to surface contamination testing, adhesion pull testing, and DFT readings as necessary to assure quality.

Inform the Engineer and the Division Safety Engineer of all scheduled and unannounced inspections from SSPC, OSHA, EPA and/or others that come on site. Furnish the Engineer a copy of all inspection reports except for reports performed by a third party and or consultant on behalf of the Contractor.

(B) Inspection Instruments

At a minimum, furnish the following calibrated instruments and conduct the following quality control tests:

- (1) Sling Psychrometer - ASTM E337 - bulb type
- (2) Surface Temperature Thermometer
- (3) Wind Speed Indicator
- (4) Tape Profile Tester - ASTM D4417 Method C
- (5) Surface Condition Standards - SSPC VIS-1 and VIS-3
- (6) Wet Film Thickness Gage - ASTM D4414
- (7) Dry Film Thickness Gage - SSPC-PA2 Modified
- (8) Solvent Rub Test Kit - ASTM D4752
- (9) Adhesion Test Kit - ASTM D3359 Method A (Tape Test)
- (10) Adhesion Pull test - ASTM D4541
- (11) Surface Contamination Analysis Kit or (Chloride Level Test Kit) SSPC Technology Guide 15

(C) Quality Control

Maintain a daily quality control record in accordance with Subarticle 442-12(D) of the *Standard Specifications* and make such records available at the job site for review by the inspector and submit to the Engineer as directed. In addition to the information required on

[Form M&T-610](#), submit all Dry Film Thickness (DFT) readings on a form equivalent to [Form M&T-611](#). These forms can be found at:
<https://connect.ncdot.gov/resources/Materials/Pages/Materials-Manual-by-Material.aspx?Method=MM-05-02>

- (1) 10 DFT readings are required. Measure DFT at equal spacings along the length of culvert. DFT readings shall be taken along each side of the arch culvert no more than 2ft above the waterline:

Each spot is an average of three (3) to five (5) individual gage readings as defined in SSPC PA-2. No spot average shall be less than 80% of minimum DFT for each layer applied; this does not apply to stripe coat application. Spot readings that are non-conforming shall be re-assessed by performing additional spot measurements not to exceed one-foot intervals on both sides of the low areas until acceptable spot averages are obtained. These non-conforming areas shall be corrected by the Contractor prior to applying successive coats.

- (2) Two (2) random adhesion tests (1 test = 3 dollies) per span are conducted on interior surfaces in accordance with ASTM D4541 (Adhesion Pull Test) after the prime coat has been properly cured in accordance with ASTM D3363 (Pencil Hardness) with no less than a two (2) resistance rating and will be touched up by the Contractor. The required minimum average adhesion is 400 psi.
- (3) Cure of the intermediate and stripe coats shall be assessed by using the thumb test in accordance with ASTM D1640 (Curing Formation Test) prior to the application of any successive layers of paint.
- (4) One random Cut Tape adhesion test per span is conducted in accordance with ASTM D3359 (X-Cut Tape Test) on interior surface after the finish coat is cured. Repair areas shall be properly tapered and touched up by the Contractor.

ZONE PAINTING

If any girder has excessive corrosion along its bottom flange, beyond the distance of 1.5 times the depth of the beam or girder, at the bearing, the area of the affected girder indicated on the plans, and other girders as directed by the Engineer, shall be cleaned in accordance with the requirements of System 5 painting system. The horizontal limits of zone painting shall extend 12” beyond the maximum horizontal extent of web/flange corrosion. The vertical limits of zone painting shall extend 3” beyond the maximum vertical extent of web corrosion.

Areas designated for zone coating shall be primed and coated in accordance with System 5 as outlined in the *Structural Steel Shop Coatings Program*.

System 5 is one coat of primer, one intermediate acrylic coat, one stripe coat of paint, and one topcoat of paint and over non-weathering steel surfaces cleaned to an SSPC SP-6 finish.

Painting shall be performed in accordance with Section 442 and Section 1080 of the *Standard Specifications*, and/ or these Special Provisions; the more restrictive requirement shall apply. Perform all mixing operations over an impervious surface with provisions to prevent runoff to grade of any spilled material.

SAFETY AND ENVIRONMENTAL COMPLIANCE PLANS

Personnel access boundaries are delineated for each work site using signs, tape, cones, or other approved means. Submit copies of safety and environmental compliance plans that comply with SSPC QP 2 Certification requirements.

HEALTH AND SAFETY RESPONSIBILITIES

This project may involve toxic metals such as arsenic, lead, cadmium and hexavalent chromium. It is the contractor's responsibility to test for toxic metals and if found, comply with the OSHA regulations, which may include medical testing.

Ensure a "Competent Person" as defined in OSHA 29 CFR 1926.62; one who is capable of identifying existing and predictable hazards in the surroundings or working conditions which are unsanitary, hazardous, or dangerous to employees, and who has authorization to take prompt corrective measures to eliminate them; is on site during all surface preparation activities and monitors the effectiveness of containment, dust collection systems and waste sampling. Before any work begins, provide a written summary of the Competent Person's safety training.

Comply with Subarticle 442-14(B) of the *Standard Specifications*.

Comply with Subarticle 442-14(D) of the *Standard Specifications*. Ensure employee blood sampling test results are less than 50 micrograms per deciliter. Remove employees with a blood sampling test of 50 or more micrograms per deciliter from work activities involving any lead exposure.

An employee who has been removed with a blood level of 50 micrograms per deciliter or more shall have two (2) consecutive blood sampling tests spaced one week apart indicating that the employee's blood lead level is at or below 40 micrograms per deciliter before returning to work activities involving any lead exposure.

All OSHA recordable accidents that occur during the project duration are to be reported to the Engineer within twenty-four (24) hours of occurrence. In addition, for accidents that involve civilians or property damage that occurs within the work zone the Division Safety Engineer shall be notified immediately.

Prior to blasting operations, the Contractor shall have an operational OSHA approved hand wash station at each bridge location and a decontamination trailer at each bridge or between bridges unless the work is on the roadway, or the Contractor shall show reason why it is not feasible to do so and provide an alternative site as approved by the Engineer. The Contractor shall assure that all employees whose airborne exposure to lead is above the Permissible Exposure Limit (PEL) shall shower at the end of their work shift.

STORAGE OF PAINT AND EQUIPMENT

Provide a location for materials, equipment, and waste storage. Spread tarpaulins over all pavements and surfaces underneath equipment used for abrasive recycling and other waste handling equipment or containers. All land and or lease agreements that involve private property shall disclose to the property owner that heavy metals may be present on the Contractor's equipment. Prior to storing the Contractor's equipment on private property, provide a notarized written consent signed by the landowner received by the Engineer at least forty-eight (48) hours before using property. All storage of paint, solvents, and other materials applied to structures shall be stored in accordance with Subarticle 442-9(C) of the *Standard Specifications* or the manufacturers' requirements. The more restrictive requirements will apply.

UTILITIES

Protect all utility lines or mains that may be supported on, under, or adjacent to bridge work sites from damage and paint overspray.

MEASUREMENT AND PAYMENT

The cost of inspection, surface preparation and repainting the existing structure is included in the lump sum price bid for *Cleaning and Painting Existing Weathering Steel for Bridge #___*. This price is full compensation for furnishing all inspection equipment, all paint, cleaning abrasives, cleaning solvents and all other materials; preparing and cleaning surfaces to be painted; applying paint in the field; protecting work area, traffic and property; furnishing blast cleaning equipment, paint spraying equipment, brushes, rollers, any other hand or power tools and any other equipment.

Pollution Control will be paid at the contract lump sum price which will be full compensation for all collection, handling, storage, air monitoring, and disposal of debris and wash water, all personal protective equipment, and all personal hygiene requirements, and all equipment, material and labor necessary for the daily collection of the blast debris into specified containers; and any measures necessary to ensure conformance to all safety and environmental regulations as directed by the Engineer.

Painting Containment for Bridge #___ will be paid at the lump sum contract price and will be full compensation for the design, materials, installation, maintenance, and removal of the containment system.

Payment will be made under:

Pay Item	Pay Unit
Cleaning and Painting Existing Steel for Culvert #___	Lump Sum
Pollution Control	Lump Sum
Painting Containment for CULVERT #___	Lump Sum

SP-06, DRIFT/DEBRIS REMOVAL

DESCRIPTION

This work shall consist of removing drift and/or debris in accordance with the contract plans, Section 200 of NCDOT *2024 Standard Specifications*, or as established by the engineer.

PROCEDURE

The drift and/or debris to be removed shall be in the areas designated on the contract plans.

MEASUREMENT AND PAYMENT

The cost of drift/debris removal is included in the lump sum price bid for Drift/Debris Removal. This price full compensation for furnishing all labor; hauling and disposal of; protecting work area, traffic and property; and any other hand or power tools and any other equipment; and a containment required for completion of satisfactory work.

Payment will be made under:

Pay Item	Pay Unit
Drift and Debris Removal	Lump Sum

SP-07, UTILITY REPAIR

DESCRIPTION

This specification handles the repair of broken utilities attached to city structures. The repairs consist of, but not limited to, broken or missing connection brackets, conduit, and hardware. The utility to be repaired may also have exposed wires. The Contractor shall submit shop drawings to the engineer for review of each repair location.

Connection Brackets are to be hot dipped galvanized per ASTM A123.

MEASUREMENT AND PAYMENT

At locations where utility repairs are called for on the plans and a pay item for Utility Repair is included in the contract, Utility Repair will be measured by each and paid as the lump sum fee that have been satisfactorily placed and accepted. Such price and payment will be full compensation for all work covered by this provision

Payment will be made under:

Pay Item

Utility Repair

Pay Unit

Lump Sum



WSP USA
434 FAYETTEVILLE STREET
SUITE 1500
RALEIGH, NC 27601
TEL: 1.919.836.4040
FAX: 1.919.836.4099
LICENSE NO. F-0165

PROJECT NAME: CITY OF RALEIGH BRIDGE REPAIRS

STRUCTURE NO.: _____ DRAWN BY: MAH

DATE: _____ CHECKED BY: MWC

NOTES:

REMOVE ANY LOOSE CONCRETE, FOREIGN MATERIALS AND/OR SURFACE CONTAMINANTS AND PREPARE THE SURFACE IN ACCORDANCE WITH SPECIAL PROVISIONS.

IF EXPOSED REINFORCING STEEL IS PRESENT, CAREFULLY REMOVE LOOSE CONCRETE BETWEEN AND BELOW REINFORCING STEEL SO AS TO NOT DAMAGE THE STEEL. REMOVE CONCRETE AT LEAST 1" PAST ANY RUST ON THE STEEL. SEE SPECIAL PROVISIONS FOR PROPER METHODS AND PROCEDURES.

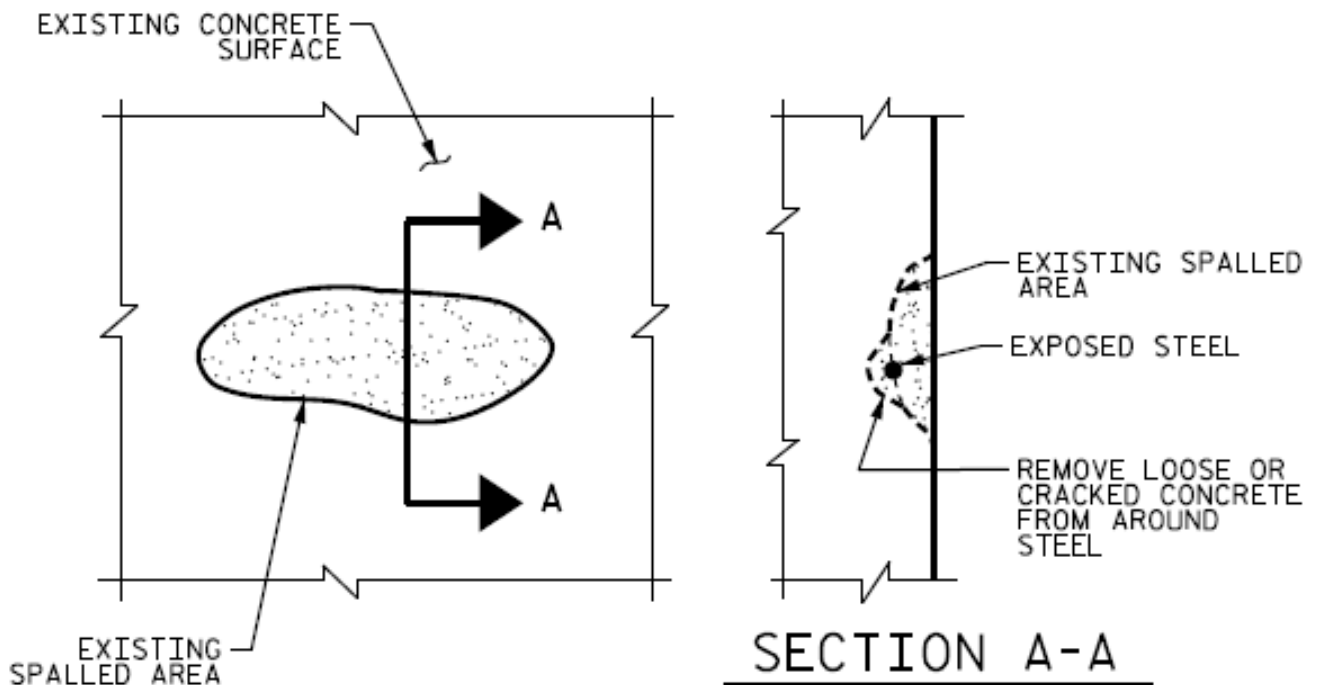

TYPICAL SPALL REPAIR

(HORIZONTAL AND VERTICAL APPLICATIONS)



WSP USA
434 FAYETTEVILLE STREET
SUITE 1500
RALEIGH, NC 27601
TEL: 1.919.836.4040
FAX: 1.919.836.4099
LICENSE NO. F-0165

PROJECT NAME: CITY OF RALEIGH BRIDGE REPAIRS

STRUCTURE NO.: _____ DRAWN BY: CJH

DATE: _____ CHECKED BY: MWC

DETAIL E-3

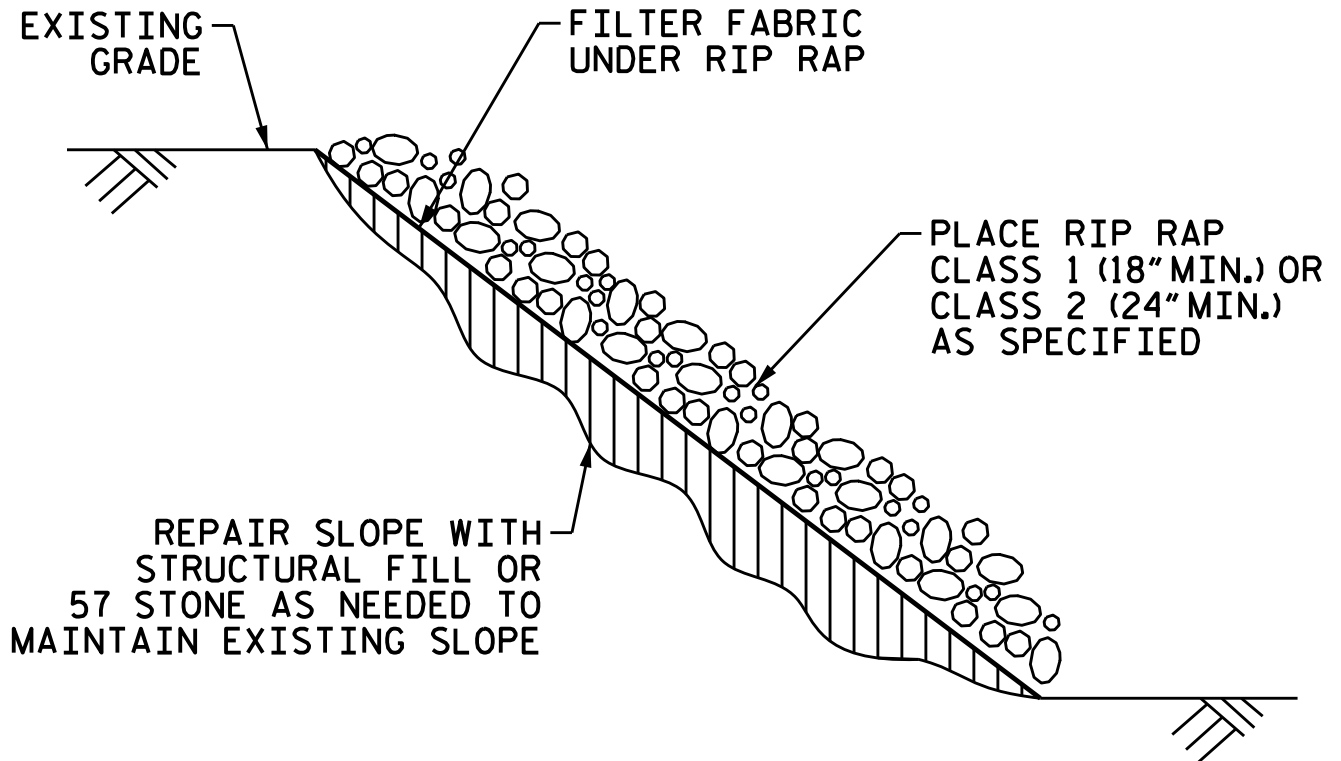

RIP RAP REPAIR



WSP USA
 434 FAYETTEVILLE STREET
 SUITE 1500
 RALEIGH, NC 27601
 TEL: 1.919.836.4040
 FAX: 1.919.836.4099
 LICENSE NO. F-0165

PROJECT NAME: CITY OF RALEIGH BRIDGE REPAIRS

STRUCTURE NO.: _____ DRAWN BY: MJO

DATE: _____ CHECKED BY: MWC

DETAIL E-4

REPAIRS

TYPE 1: SCOUR NOT UNDERMINING THE STRUCTURE
 -REMOVE ALL DEBRIS FROM THE SCOUR HOLE AND PLACE RIP RAP IN THE AREA LETTING THE SILT TO EVENTUALLY FILL THE VIODS BETWEEN THE RIP RAP

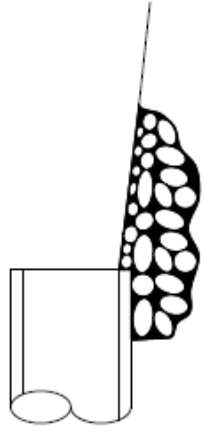

TYPE 2

TYPE 2: SCOUR UNDERMINING THE STRUCTURE
 -REMOVE ALL DEBRIS FROM THE SCOUR HOLE AND PLACE RIP RAP IN THE AREA THEN PLACE FLOWABLE FILL TO FILL ANY VIODS BETWEEN THE RIP RAP

TYPE 3: SCOUR BEHIND A WING WALL
 -CLEAN AREA OF ANY VEGETATION AND LOOSE SOIL AND PLACE RIP RAP

TYPE 4: SCOUR OCCURING IN STREAM BEDS
 -HAND PLACE RIP RAP IN VOID AREA OF STREAM BED TO MATCH EXISTING STREAM PROFILE

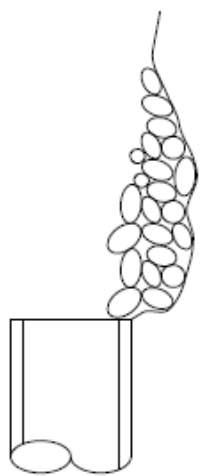

TYPE 1

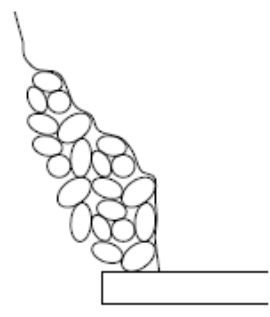

TYPE 3

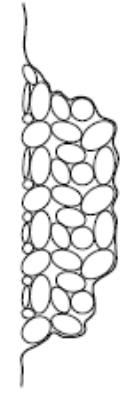

TYPE 4

SCOUR REPAIR



WSP USA
 434 FAYETTEVILLE STREET
 SUITE 1500
 RALEIGH, NC 27601
 TEL: 1.919.836.4040
 FAX: 1.919.836.4099
 LICENSE NO. F-0165

PROJECT NAME: CITY OF RALEIGH BRIDGE REPAIRS

STRUCTURE NO.: _____ DRAWN BY: MJO

DATE: _____ CHECKED BY: MWC

DETAIL J-17

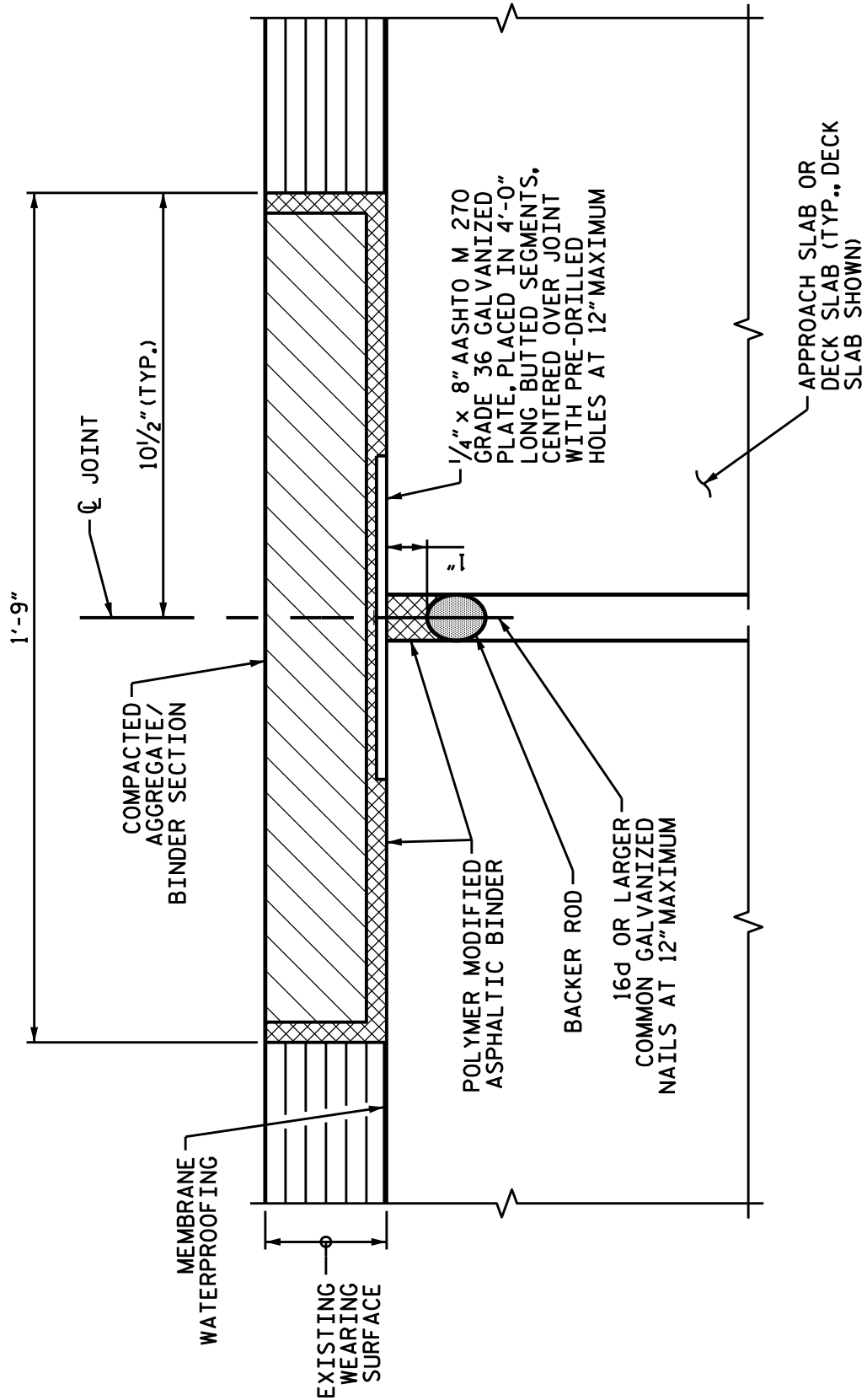

ASPHALTIC BRIDGE JOINT DETAIL

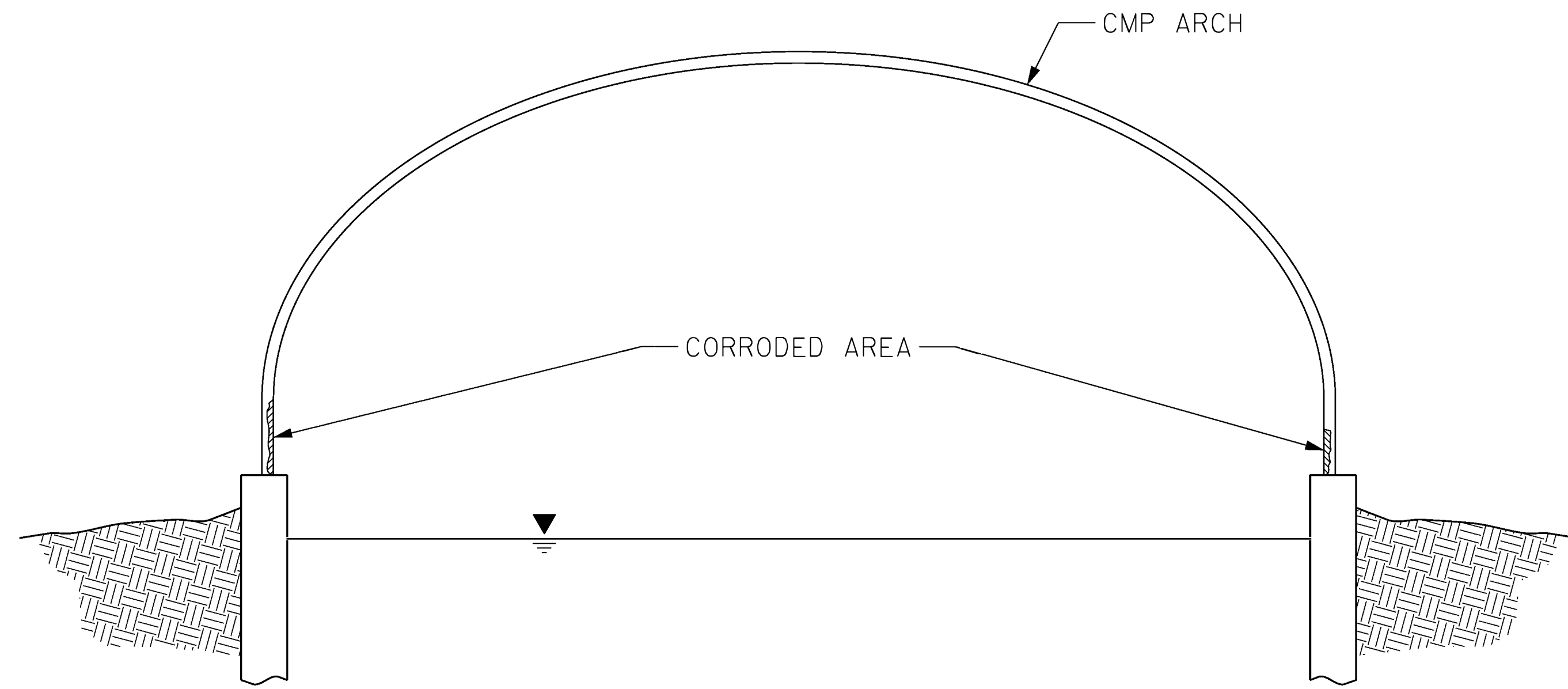

DETAIL 1

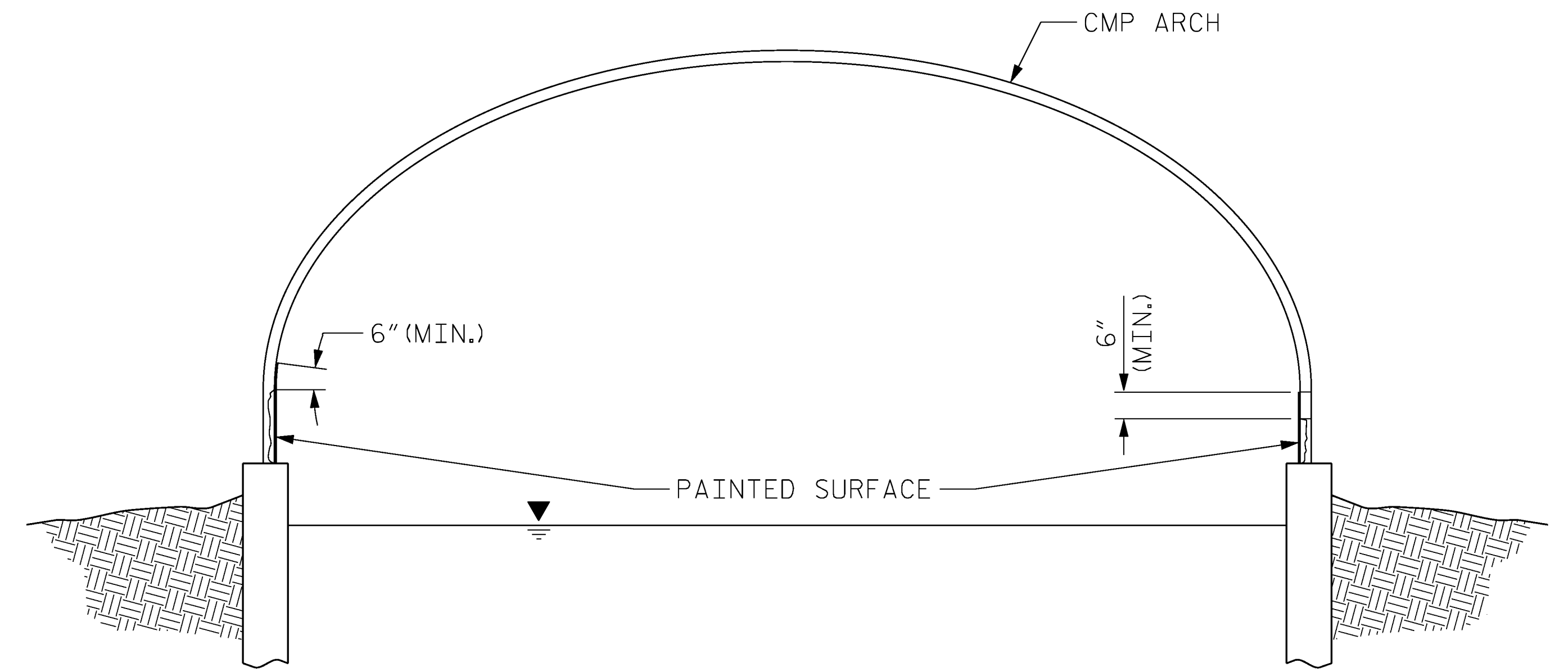

DETAIL 2

REPAIR SEQUENCE:

1. CLEAN AND PREP THE CORRODED AREA OF CMP ARCH AS SHOWN IN DETAIL 1.
2. PAINT THE CORRODED AREA OF CMP ARCH PER DETAIL 2.

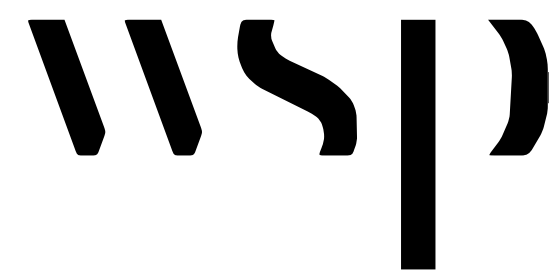

WSP USA
 434 FAYETTEVILLE STREET
 SUITE 1500
 RALEIGH, NC 27601
 TEL: 1.919.836.4040
 FAX: 1.919.836.4099
 LICENSE NO. F-0165

DETAIL P-4
 PAINTING OF CMP ARCH CULVERT

PROJECT NAME: CITY OF RALEIGH BRIDGE REPAIRS
 STRUCTURE NO.: _____ DRAWN BY: M.J. OSTRISHKO
 DATE: DECEMBER 2016 CHECKED BY: C.J. HOWARD