



## INFORMAL BID REQUEST # 25-26-53

**Bid Due Date: Thursday, July 8th, 2026 @ 4:00 pm**

### SPEED CUSHION INSTALLATION

The City of Greenville, NC (City) is in need of a contractor to install speed cushions along designated streets in Greenville, NC (see Attachment E).

All work and materials shall be in accordance with the provisions of the General Guidelines of this contract, the Project Special Provisions, the North Carolina Department of Transportation Standard Specifications for Roads and Structures, the North Carolina Department of Transportation Roadway Standards Drawings, the current edition of the Manual of Uniform Traffic Control Devices (MUTCD), and the Traffic Signal Specifications and all addenda.

The Contractor shall keep himself fully informed of all Federal, State and local laws, ordinances, and regulations.

### **SCOPE OF WORK**

The work entails drilling, epoxy and lag bolting the speed cushions to the pavement. The City has done their due diligence and are unaware of any subsurface conditions that would necessitate a change to the normal installation process (see Attachment D).

All of the materials required to complete the installation described above will be provided by the City, but the Contractor shall be responsible for picking up the materials at the Public Works Compound, Building E.

The anticipated equipment required for the installation includes:

- Vehicles to transport the materials from PW to the job site;
- Pick-up trucks to haul the actual tools required
- Compressed air to clean area and drill holes
- Portable drills (chargeable)
- Regular electric drills
- Gas powered generators to power the electric drills
- Drill bits (to be defined with selected Contractor)
- Caulking guns

It is assumed that the contractor will also provide the traffic control to install each location. It is also assumed based on the locations on residential streets, that traffic control can be accomplished by a standard flagging operation.

The locations will be located in the field by City staff. Traffic technicians will be on-site to direct the Contractor on the installation process.

### **TRAFFIC CONTROL AND WORK ZONE SAFETY**

The Contractor shall maintain traffic during construction and provide, install, and maintain all traffic control devices in accordance with these project guidelines, the Project Special Provisions, North Carolina Department of Transportation Standard Specifications for Roads and Structures 1995, and the current edition of the Manual of Uniform Traffic Control Devices (MUTCD).

The Contractor shall utilize complete and proper traffic controls and traffic control devices during all operations. All traffic control and traffic control devices required for any operation shall be functional and in place prior to the commencement of that operation. Signs for temporary operations shall be removed during periods of inactivity. The Contractor is required to leave the project in a manner that will be safe to the traveling public and which will not impede motorists.

Traffic movements through lane closures on roads with two-way traffic shall be controlled by flaggers stationed at each end of the work zone. In situations where sight distance is limited, the Contractor shall provide additional means of controlling traffic, including, but not limited to, two-way radios, pilot vehicles, or additional flaggers. Flaggers shall be competent personnel, adequately trained in flagging procedures, and furnished with proper safety devices and equipment, including, but not limited to, safety vests and stop/slow paddles.

All personnel when working in traffic areas or areas in close proximity to traffic shall wear an approved safety vest, or shirt or jacket which meets the color requirements of the Manual of Uniform Traffic Control Devices (MUTCD).

The Contractor shall comply with all applicable Federal, State, and local laws, ordinances, and regulations governing safety, health, and sanitation, and shall provide all safeguards, safety devices, and protective equipment, and shall take any other needed actions, on his own responsibility that are reasonably necessary to protect the life and health of employees on the job and the safety of the public, and to protect property in connection with the performance of the work covered by the contract.

Failure to comply with any of the requirements for safety and traffic control of this contract shall result in suspension of work.

### **SUPERVISION BY CONTRACTOR**

At all times during the life of the project the Contractor shall provide one permanent employee who shall have the authority and capability for overall responsibility of the project and who shall be personally available at the work site within 24 hours notice. Such employee shall be fully authorized to conduct all business with the subcontractors, to negotiate and execute all supplemental agreements, and to execute the orders or directions of the Engineer.

At all times that work is actually being performed, the Contractor shall have present on the project one competent individual who is authorized to act in a supervisory capacity over all work on the project, including work subcontracted. The individual who has been so authorized shall be experienced in the type of work being performed and shall be fully capable of managing, directing, and coordinating the work; of reading and thoroughly understanding the contract; and receiving and carrying out directions from the Engineer or his authorized representatives. He shall be an employee of the Contractor unless otherwise approved by the Engineer.

The Contractor may, at his option, designate one employee to meet the requirements of both positions. However, whenever the designated employee is absent from the work site, an authorized individual qualified to act in a supervisory capacity on the project shall be present.

### **CLEAN THE WORKSITE**

The contractor shall clean the site of debris, which results from installing the speed cushions. At the end of each workday, the site shall be cleaned and cleared. The contractor will haul away any waste material to an approved public landfill.

### **METHOD OF MEASUREMENT**

The quantity of speed cushions to be paid for will be the actual number of speed cushions installed, which have been satisfactorily placed and accepted by the Engineer.

### **COMPENSATION**

Such price and payment will be full compensation for all work covered by this provision.

### **PROJECT SCHEDULE**

The City expects to award the contract for this project in July of 2026.

### **CONTRACT TERM**

The contract term will be three (3) months with no extension.

**CONTRACT PAYMENT:** Lump Sum

**PROSECUTION AND PROGRESS**

The Contractor shall pursue the work diligently with workmen in sufficient numbers, abilities, and supervision, and with equipment, materials, and methods of construction as may be required to complete the work described in the contract by the completion date.

The Contractor's operations are restricted to daylight hours. No work may be performed on weekends or legal City holidays. Work shall only be performed when weather and visibility conditions allow safe operations. The Contractor shall not close lanes or restrict traffic between the hours of 7:00 a.m. - 9:00 a.m. and 4:00 p.m. - 6:00 p.m. on weekdays.

**PROPOSAL SUBMITTAL REQUIREMENTS:**

All informal bids (G.S. 143-131) for this project shall be prepared and submitted in accordance with the following requirements. Failure to comply with any requirement shall cause the bid to be considered nonresponsive and shall be grounds for rejection of the bid.

1. The bid sheet furnished by the City of Greenville with the proposal shall be used and shall not be altered in any manner. DO NOT SEPARATE THE BID SHEET FROM THE PROPOSAL!
2. The Bidder shall submit a unit price for every item on the bid form. The unit prices for the various contract items shall be written numerically.
3. An amount bid shall be entered on the bid sheet for every item. The amount bid for each item shall be determined by multiplying each unit bid by the quantity for that item, and shall be written numerically in the "Amount Bid" column of the sheet.
4. The total amount bid shall be written numerically in the proper place on the bid sheet. The total amount shall be determined by adding the amounts bid for each item.
5. Changes in any entry shall be made by marking through the entry in ink and making the correct entry adjacent thereto in ink. A representative of the Bidder shall initial the change in ink.
6. The bid shall be properly executed per ATTACHMENT A. All bids shall show the following information:
  - a. Name of individual or representative submitting bid and position or title.
7. Bids submitted by corporations shall bear the seal of the corporation.
8. The bid shall not contain any unauthorized additions, deletions, or conditional bids.
9. The bidder shall not add any provision reserving the right to accept or reject an award, or to enter into a contract pursuant to an award.

**QUESTIONS:**

Questions must be asked in writing via email addressed to Stacey Pigford at [spigford@greenvillenc.gov](mailto:spigford@greenvillenc.gov) with the IFB number 25-26-53 mentioned in the subject line of the email. All questions must be submitted by Thursday, June 25, 2026 by 12:00 noon, and answers will be provided via an addendum posted on the City's website.

**PROPOSAL SUBMISSION AND DEADLINE:**

Bid shall be submitted in PDF format electronically to [spigford@greenvillenc.gov](mailto:spigford@greenvillenc.gov) by **4:00 pm on Wednesday, July 8, 2026.**

**Proposals submitted after this deadline or to any location other than that listed above will not be considered.**

**RIGHT TO REJECT:**

The City reserves the right to reject any or all proposals. NOTWITHSTANDING anything to the contrary in this document or in any addendums to this document, unless the provision refers specifically to this provision, the City reserves the right (i) to negotiate changes of any nature with any firm proposing to do the work with respect to any term, condition, or provision in this document and/or in any proposals, whether or not something is stated to be mandatory and whether or not it is said that a proposal will be rejected if certain information or documentation is not submitted with it, and (ii) to enter into an agreement for the work with one or more firms that do not submit proposals. For example, all deadlines are for the administrative convenience or needs of the City and may be waived by the City in its discretion.

**AWARD OF CONTRACT**

The award of the contract, if awarded, will be made to the lowest responsive, responsible bidder. The lowest responsive, responsible will be notified that his bid has been accepted and that he has been awarded the contract. The City of Greenville reserves the right to reject all bids.

**VENDOR SELF SERVICE**

New vendors must register online at the City of Greenville Vendor Self Service portal: <https://cityofgreenvillenc.munisselfservice.com/vss>. This does not have to be completed to submit a bid, however, the bidder must be a registered vendor prior to award of the contract.

**MINORITY AND WOMEN-OWNED BUSINESS ENTERPRISE PARTICIPATION**

It is the policy of the City to provide minorities and women equal opportunity for participating in all aspects of the City's contracting and procurement programs,

including but not limited to, construction projects, supplies and materials purchase, and professional and personal service contracts. In accordance with this policy, the City has adopted a Minority and Women Business Enterprise (MWBE) Plan and subsequent program, outlining verifiable goals.

The City has established a 4% Minority Business Enterprise (MBE) and 4% Women Business Enterprise (WBE) **goal** for the participation of MWBE firms in supplying goods and services for the completion of this project. All firms submitting qualifications and/or proposals agree to employ “good faith efforts” towards achieving these goals and supply other information as included in Attachment C. Failure to complete the MWBE forms may be cause to deem the submittal nonresponsive.

Questions regarding the City’s MWBE Program should be directed to Wanda House, Financial Services Manager at (252) 329-4862.

**EQUAL EMPLOYMENT OPPORTUNITY CLAUSE**

The City of Greenville is an equal opportunity employer and strictly prohibits discrimination against any employee or applicant for employment because of the individual’s race, color, religion, age, gender, disability, national origin, genetic information, sexual orientation, gender identity/reassignment or expression, military or veteran status, marital status, or any characteristic protected by applicable law.

Federal law (Rehabilitation Act and ADA) prohibits handicapped discrimination by all governmental units. By submitting a proposal, the vendor is attesting to its policy of nondiscrimination regarding the handicapped.

**TITLE VI NONDISCRIMINATION NOTIFICATION**

The City of Greenville, North Carolina in accordance with the provisions of Title VI of the Civil Rights Act of 1964 (78 Stat. 252, 42 U.S.C. §§ 2000d to 2000d-4) and the Regulations, hereby notifies all respondents that it will affirmatively ensure that any contract entered into pursuant to this advertisement, disadvantaged business enterprises will be afforded full and fair opportunity to submit proposals in response to this advertisement and will not be discriminated against on the grounds of race, color, or national origin in consideration for an award.

**Title VI of the Civil Rights Act of 1964  
Nondiscrimination Provisions, Appendices A & E.**

During the performance of this contract, the contractor, for itself, its assignees, and successors in interest (hereinafter referred to as the "contractor") agrees as follows:

**1) Compliance with Regulations:** The contractor (hereinafter includes consultants) will comply with the Acts and the Regulations relative to Nondiscrimination in Federally-assisted programs of the U.S. Department of Transportation (USDOT), as they may be amended from time to time, which are herein incorporated by reference and made a part of this contract.

**(2) Nondiscrimination:** The contractor, with regard to the work performed by it during the contract, will not discriminate on the grounds of race, color, national origin, sex, age, creed (religion), low-income, limited English proficiency, or disability in the selection and retention of subcontractors, including procurements of materials and leases of equipment. The contractor will not participate directly or indirectly in the discrimination prohibited by the Acts and the Regulations, including employment practices when the contract covers any activity, project, or program set forth in Appendix B of 49 CFR Part 21.

**(3) Solicitations for Subcontractors, Including Procurements of Materials and Equipment:** In all solicitations, either by competitive bidding, or negotiation made by the contractor for work to be performed under a subcontract, including procurements of materials, or leases of equipment, each potential subcontractor or supplier will be notified by the contractor of the contractor's obligations under this contract and the Acts and the Regulations relative to Nondiscrimination on the grounds of race, color, or national origin.

**(4) Information and Reports:** The contractor will provide all information and reports required by the Acts, the Regulations, and directives issued pursuant thereto and will permit access to its books, records, accounts, other sources of information, and its facilities as may be determined by the Recipient or the USDOT to be pertinent to ascertain compliance with such Acts, Regulations, and instructions. Where any information required of a contractor is in the exclusive possession of another who fails or refuses to furnish the information, the contractor will so certify to the Recipient or the USDOT, as appropriate, and will set forth what efforts it has made to obtain the information.

**(5) Sanctions for Noncompliance:** In the event of a contractor's noncompliance with the Non-discrimination provisions of this contract, the Recipient will impose such contract sanctions as it or the USDOT may determine to be appropriate, including, but not limited to: (a) withholding payments to the contractor under the contract

until the contractor complies; and/or (b) cancelling, terminating, or suspending a contract, in whole or in part.

**(6) Incorporation of Provisions:** The contractor will include the provisions of paragraphs one through six in every subcontract, including procurements of materials and leases of equipment, unless exempt by the Acts, the Regulations and directives issued pursuant thereto. The contractor will take action with respect to any subcontract or procurement as the Recipient or the USDOT may direct as a means of enforcing such provisions including sanctions for noncompliance. Provided, that if the contractor becomes involved in, or is threatened with litigation by a subcontractor, or supplier because of such direction, the contractor may request the Recipient to enter into any litigation to protect the interests of the Recipient. In addition, the contractor may request the United States to enter into the litigation to protect the interests of the United States.

During the performance of this contract, the contractor, for itself, its assignees, and successors in interest (hereinafter referred to as the "contractor") agrees to comply with the following nondiscrimination statutes and authorities; including but not limited to:

Pertinent Nondiscrimination Authorities • Title VI of the Civil Rights Act of 1964 (42 U.S.C. § 2000d et seq., 78 stat. 252), (prohibits discrimination on the basis of race, color, national origin); and 49 CFR Part 21.

- The Uniform Relocation Assistance and Real Property Acquisition Policies Act of 1970, (42 U.S.C. § 4601), (prohibits unfair treatment of persons displaced or whose property has been acquired because of Federal or Federal-aid programs and projects);
- Federal-Aid Highway Act of 1973, (23 U.S.C. § 324 et seq.), (prohibits discrimination on the basis of sex);
- Section 504 of the Rehabilitation Act of 1973, (29 U.S.C. § 794 et seq.), as amended, (prohibits discrimination on the basis of disability); and 49 CFR Part 27;
- The Age Discrimination Act of 1975, as amended, (42 U.S.C. § 6101 et seq.), (prohibits discrimination on the basis of age);
- Airport and Airway Improvement Act of 1982, (49 USC § 471, Section 47123), as amended, (prohibits discrimination based on race, creed, color, national origin, or sex);
- The Civil Rights Restoration Act of 1987, (PL 100-209), (Broadened the scope, coverage and applicability of Title VI of the Civil Rights Act of 1964, The Age

Discrimination Act of 1975 and Section 504 of the Rehabilitation Act of 1973, by expanding the definition of the terms "programs or activities" to include all of the programs or activities of the Federal-aid recipients, sub-recipients and contractors, whether such programs or activities are Federally funded or not);

- Titles II and III of the Americans with Disabilities Act, which prohibit discrimination on the basis of disability in the operation of public entities, public and private transportation systems, places of public accommodation, and certain testing entities (42 U.S.C. §§ 12131-12189) as implemented by Department of Transportation regulations at 49 C.F.R. parts 37 and 38;
- The Federal Aviation Administration's Nondiscrimination statute (49 U.S.C. § 47123) (prohibits discrimination on the basis of race, color, national origin, and sex);
- Executive Order 12898, Federal Actions to Address Environmental Justice in Minority Populations and Low-Income Populations, which

Executive Order 12898, Federal Actions to Address Environmental Justice in Minority Populations and Low-Income Populations, which ensures Nondiscrimination against minority populations by discouraging programs, policies, and activities with disproportionately high and adverse human health or environmental effects on minority and low-income populations;

- Executive Order 13166, Improving Access to Services for Persons with Limited English Proficiency, and resulting agency guidance, national origin discrimination includes discrimination because of Limited English proficiency (LEP). To ensure compliance with Title VI, you must take reasonable steps to ensure that LEP persons have meaningful access to your programs (70 Fed. Reg. at 74087 to 74100);
- Title IX of the Education Amendments of 1972, as amended, which prohibits you from discriminating because of sex in education programs or activities (20 U.S.C. 1681 et seq);
- Federal transit laws, specifically 49 U.S.C. § 5332 (prohibiting discrimination based on race, color, religion, national origin, sex (including gender identity), disability, age, employment, or business opportunity).

**Road List for Speed Cushion Installations**

<b>Street</b>	<b>No. of Locations</b>	<b>Speed Cushions at each location</b>	<b>Total</b>
Nash St	2	3	6
E. 4 <sup>th</sup> St	5	3	15
Crestline Blvd	1	3	3
W. Meath Dr	2	3	6
Wildwood Park	4	2	8
Club Pines Dr	1	3	3
Brownlea Dr	2	4	8
			<b>Total: 49</b>

**ATTACHMENT A**  
**City of Greenville**  
**BID FORM**

**Description:** Installation of speed cushions.

**Location:** Various locations along neighborhood streets in the City of Greenville.

ITEM	DESCRIPTION	QUANTITY	UNIT	UNIT PRICE	AMOUNT BID
1	Install speed cushions (traffic control included in install price)	49	EA		
2	Remove speed cushions	9	EA		
3	Mobilization				

***TOTAL BID FOR PROJECT:*** \_\_\_\_\_

**CONTRACTOR:**

**By:** \_\_\_\_\_

Name: \_\_\_\_\_

Title: \_\_\_\_\_

Email: \_\_\_\_\_

**ATTACHMENT B**  
**GENERAL TERMS AND CONDITIONS**

The contract terms provided herein are not exhaustive but shall become a part of any contract issued as a result of this solicitation. Any exceptions to the contract terms must be stated in the submittal. Any submission of a proposal without objection to the contract terms indicates understanding and intention to comply with the contract terms. If there is a term or condition that the firm intends to negotiate, it must be stated in the proposal. The successful firm will not be entitled to any changes or modifications unless they were first stated in the proposal. The City reserves the right, at its sole discretion, to reject any or all submittal package(s) containing unreasonable objections to standard City contract provisions.

1. **NONDISCRIMINATION:** The contractor, with regard to the work performed by it during the contract, will not discriminate on the grounds of race, color, national origin, sex, age, disability, income-level, or LEP in the selection and retention of subcontractors, including procurements of materials and leases of equipment. The contractor will not participate directly or indirectly in the discrimination prohibited by the Acts and the Regulations as set forth in Appendix E, including employment practices when the contract covers any activity, project, or program set forth in Appendix B of 49 C.F.R. part 21.
  
2. **SOLICITATIONS FOR SUBCONTRACTS, INCLUDING PROCUREMENTS OF MATERIALS AND EQUIPMENT:** In all solicitations, either by competitive bidding, or negotiation made by the contractor for work to be performed under a subcontract, including procurements of materials, or leases of equipment, each potential subcontractor or supplier will be notified by the contractor of the contractor's obligations under this contract and the Acts and the Regulations relative to Non-discrimination on the grounds of race, color, national origin, sex, age, disability, income-level, or LEP.
  
3. **NON-COLLUSION:** Respondents, by submitting a signed proposal, certify that the accompanying submission is not the result of, or affected by, any unlawful act of collusion with any other person or company engaged in the same line of business or commerce, or any other fraudulent act punishable under North Carolina or United States law.
  
4. **PAYMENT TERMS:** The City agrees to pay all approved invoices Net Thirty (30) days from the date received and approved. The City does not agree to the payment of late charges or finance charges assessed by the seller or vendor for any reason. Invoices are payable in U.S. funds. However, the City

shall not be obligated to make payment to the Contractor for any services performed under this contract.

5. **GOVERNING LAW:** Any agreement, contract or purchase order resulting from this invitation to bid, request for proposals or request for qualifications or quotes, shall be governed by the laws of the State of North Carolina without regard to its choice of law provisions, and venue for any action or suits arising out of or relating to this contract shall be the North Carolina General Courts of Justice, in Pitt County, or if in federal court, in the Eastern District of North Carolina.
6. **SERVICES PERFORMED:** All services rendered under this agreement will be performed at the Contractor's own risk and the Contractor expressly agrees to indemnify and hold harmless the City, its officers, agents, independent contractors, officials (elected and appointed) and employees from any and all liability, loss or damage that they may suffer as a result of claims, demands, actions, damages or injuries of any kind or nature whatsoever by or to any and all persons or property. Additionally, all work performed under this Contract shall be performed in a workmanlike and professional manner, to the reasonable satisfaction of the City, and shall conform to all prevailing industry and professional standards.
7. **INDEPENDENT CONTRACTOR:** It is mutually understood and agreed the Seller is an independent contractor and not an agent of the City, and as such, Contractor, his or her agents and employees shall not be entitled to any City employment benefits, such as but not limited to vacation, sick leave, insurance, worker's compensation, pension or retirement benefits.
8. **VERBAL AGREEMENT:** The City will not be bound by any verbal agreements.
7. **INSURANCE REQUIREMENTS:** Contractor shall maintain at its own expense (a) Commercial General Liability Insurance in an amount not less than \$1,000,000 per occurrence for bodily injury or property damage; City of Greenville, North Carolina, 200 W. Fifth St. Greenville, NC 27834 shall be named as additional insured. (b) Professional Liability insurance in an amount not less than \$1,000,000 per occurrence-if providing professional services; (c) Workers Compensation Insurance as required by the general statutes of the State of North Carolina and Employer's Liability Insurance not less than \$1,000,000 each accident for bodily injury by accident, \$1,000,000 each employee for bodily injury by disease, and \$1,000,000 policy limit; (d) Commercial Automobile Insurance applicable to bodily injury and property damage, covering all owned, non-owned, and hired vehicles, in an amount

not less than \$1,000,000 per occurrence as applicable. Certificates of Insurance shall be furnished prior to the commencement of Services

8. **INDEMINIFICATION AND HOLD HARMLESS**: All services rendered under this agreement will be performed at the Contractor's own risk and the Contractor shall indemnify and hold harmless the City from and against any liability, loss, cost, damage suit, claim, or expense arising occurrence on the part of the CONTRACTOR and its officers, servants, agents or employees arising from its activities, operations, and performance of services under this contract and further agrees to release and discharge the City and its agents and employees from all claims or liabilities arising from or caused by the CONTRACTOR in fulfilling its obligation under this contract. It is understood and agreed by the parties that City will assume no liability for damages, injury, or other loss to the Contractor, its employees or property, tools or equipment, or to other persons or properties located on City facilities resulting from the CONTRACTOR'S activities and operations while performing services under this contract.
  
9. **E-VERIFY COMPLIANCE**: The Contractor shall comply with the requirements of Article 2 of Chapter 64 of the North Carolina General Statutes. Further, if the Contractor utilizes a Subcontractor, the Contractor shall require the Subcontractor to comply with the requirements of Article 2 of Chapter 64 of the North Carolina General Statutes. By submitting a proposal, the Proposer represents that their firm and its Subcontractors are in compliance with the requirements of Article 2 Chapter 64 of the North Carolina General Statutes.
  
10. **IRAN DIVESTMENT ACT**: By submitting a proposal, the Vendor certifies that: (i) it is not on the Iran Final Divestment listed created by the N.C. State Treasurer pursuant to N.C.G.S. 147-86.58; (ii) it will not take any actions causing it to appear on said list during the term of any contract with the City, and (iii) it will not utilize any subcontractor to provide goods and services hereunder that is identified on said list.
  
11. **ADVERTISING**: The Contractor shall not use the existence of this Contract, or the name of the City, as part of any advertising without the prior written approval of the City.
  
12. **FORCE MAJEURE**: Except as otherwise provided in environmental laws, rules, regulations or ordinances applicable to the parties and the services performed under this contract, neither party shall be deemed to be in default of its obligations hereunder if and so long as it is prevented from performing such obligations by any acts of God; acts of the public enemy; insurrections; riots; embargoes; labor disputes, including strikes, lockouts, job actions, or

boycotts; shortages of materials or energy; fires; explosions; floods; any curtailment, order, regulation, or restriction imposed by governmental, military or lawfully established civilian authorities, including, without limitation any of the foregoing which occur as a result of epidemic or pandemic; changes in laws governing this type of Work of facility; or other unforeseeable causes beyond the reasonable control and without the fault or negligence of the City. Reasonable extension of time for unforeseen delays may be made by mutual written consent of all parties involved or the contract may terminate.

13. **ASSIGNMENT:** This Contract, including payment due under this contract, may not be assigned without the express written consent of the City.

14. **CONFLICT OF INTERESTS:**

- a. Contractor is aware of the conflict of interest laws of the City of Greenville, of the State of North Carolina (as set forth in North Carolina General Statutes), and agrees that it will fully comply in all respects with the terms thereof and any future amendments.
- b. Contractor covenants that no person or entity under its employ, presently exercising any functions or responsibilities in connection with this Agreement has any personal financial interests, direct or indirect, with the City. Contractor further covenants that, in the performance of this Agreement, no person or entity having such conflicting interest shall be utilized in respect to the Scope of Work or services provided hereunder. Any such conflict of interest(s) on the part of Contractor, its employees or associated persons or entities shall be disclosed to the City.
- c. Contractor shall disclose any possible conflicts of interest or apparent improprieties of any party under or in connection with the Legal Requirements, including the standards for procurement.
- d. Contractor shall make any such disclosure to the City in writing and immediately upon the Contractor's discovery of such possible conflict. The City's determination regarding the possible conflict of interest shall be binding on all parties.
- e. No employee, agent, contractor, elected official or appointed official of the City, exercising any functions or responsibilities in connection with this Agreement, or who is in a position to participate in the decision-making process or gain inside information regarding activities, has any personal financial interest, direct or indirect, in this Agreement, the

proceeds hereunder, the Project or Contractor, either for themselves or for those with whom they have family or business ties, during their tenure or for one year thereafter.

15. **TERMINATION:** The City may terminate this Contract at any time by providing thirty (30) days written notice to the Contractor. In addition, if Contractor shall fail to fulfill in timely and proper manner the obligations under this Contract for any reason, including the voluntary or involuntary declaration of bankruptcy, the City shall have the right to terminate this Contract by giving written notice to the Contractor and termination will be effective upon receipt. Contractor shall cease performance immediately upon receipt of such notice. The Contractor shall not be relieved of liability to the City for damages sustained by the City by virtue of any breach of this Contract, and the City may withhold any payment due to the Contractor for the purpose of setoff until such time as the City can determine the exact amount of damages due the City because of the breach.

(Please Attach with Bid)

**ATTACHMENT C: SUPPLEMENTAL VENDOR INFORMATION**

**MWBE AND ELIGIBLE LOCAL BIDDERS**

Minority and Women Business Enterprises (MWBEs) consist of minority, women and disabled business firms that are at least fifty-one percent owned and operated by an individual(s) of these categories. Also included are disabled business enterprises and non-profit work centers for the blind and severely disabled. Eligible Local Bidders consist of firms located within the Greenville city limits or ETJ that meet other criteria as outlined in Resolutions 031-15, 020-16.

Pursuant to G.S. 143-128.2, 143-48, 143-128.4, and the City of Greenville MWBE Plan along with Resolutions 031-15 and 020-16, the City invites and encourages participation in this procurement process by businesses owned by minorities, women, disabled business enterprises and non-profit work centers for the blind and severely disabled and local bidders. This includes utilizing subcontractors to perform the required functions in this solicitation.

The Vendor shall respond to the questions below.

- a) Are you an MWBE firm?  Yes  No
- b) Are you certified with North Carolina as a Historically Underutilized Business (MWBE)?  Yes  No
- c) Are you a certified Disadvantaged Business Enterprise (DBE) with the Department of Transportation?  
 Yes  No
- d) Are you a local bidder?  Yes  No

Please provide complete *physical* address of firm:

---

---

# INSTALLING MODULAR TRAFFIC CALMING SYSTEMS - SPEED CUSHIONS, SPEED HUMPS, OR SPEED TABLES



AS DETAILED IN THE LIMITED WARRANTY PROVIDED IN CONNECTION WITH YOUR PURCHASE OF THIS PRODUCT, THE TRAFFIC LOGIX LIMITED WARRANTY ONLY APPLIES TO TRAFFIC CALMING PRODUCTS THAT ARE CORRECTLY INSTALLED AND MAINTAINED. FOR ADDITIONAL DETAILS ON SAFE USAGE OF TRAFFIC CALMING PRODUCTS, PLEASE REFER TO THE CONDITIONAL TERMS OF USE PROVIDED TO YOU.

## Precautions



**WARNING: RISK OF INJURY** From a safety point of view, steel-toed boots, safety gloves, and standard safety precautions are required.



**WARNING: RISK OF ROAD HAZARD AND INJURY** Quarterly inspections must be made of each traffic calming device; if the Product has been damaged in any way, it must be replaced.



**CAUTION:** Traffic Calming Products must be installed in such a way that they are visible from at least 200 feet (60 m). For safe usage, Traffic Logix products must be installed with appropriate signage in accordance with the ITE *State of the Practice on Traffic Calming* guide and the *Manual on Uniform Traffic Control Devices* (MUTCD), or in Canada in accordance with the standards put in place by the Transport Association of Canada (TAC), Canadian Institute of Transportation Engineers (CITE), and the Quebec Ministère des Transports (MTQ).

Additional precautions:

- Make sure that the units are tight and well aligned before moving from one step to another.
- Make sure the holes are clear of dust and debris before installing the anchors.
- Make sure to install the appropriate Rubber Traffic Calming Device for the speed limit of the roadway. Refer to the [Traffic Logix Rubber Overview](#) Web page and Traffic Logix Sales for details.
- Traffic Calming Products must be removed in the fall prior to the arrival of snow and reinstalled in the spring after the last snow storm.

**IMPORTANT:** Before you begin, refer to the *Rubber Conditional Use Warranty* document for additional safety guidelines and installation standards.

Supplied hardware	Tools and hardware you'll need
Lag bolts, washers and nylon anchors	Chalk, plumb line, street broom, measuring tape, utility knife or hack saw (used for trimming the rubber as needed), crow bars, gooseneck wrecking bars, 3-lb (1.4 kg) hammer, 10-lb (4.5 kg) sledge hammer (for final adjustment)
Traffic Logix anchor adhesive	High-speed heavy duty impact or hammer drills (preferably spline drills)
Traffic Logix anchor T-bar tool	Drill bits: carbide tip, 9/16-in. (14 mm) dia., x 12-in. (30 cm) or 18-in. (46 cm) L
<b>Available for purchase from Traffic Logix:</b>	11/16-in. (17 mm) drive socket with a 12-in. (30 cm) extension
• Carbide drill bit 9/16" x 18" (14 mm x 46 cm): \$65.00 each	Air compressor to maintain 120 PSI (8.3 Bar, used to blow out debris after the holes are drilled)
• Adhesive tubes (12-18 holes): \$15.00 per tube	Heavy duty generator and extension cords
• Adhesive dispenser gun: \$65.00 each	General purpose hammer - Hand held sledge hammer

## Installing the traffic calming modules



**CAUTION: Moisture must not be present in or around the product during installation for the anchor adhesive to be effective.**

1. Clean the surrounding installation area with the street broom. Free area from pebbles and all debris.
2. Using the chalk, mark a line parallel to the curb and one that is perpendicular to the road. Use these lines to square up your Traffic Calming Product. Leave the chalk lines in view, allowing the module edges to touch the lines.



3. Identify and separate the pieces that run parallel to the curb for both sides of the Traffic Calming Product.



4. Assemble and position the first row of outside units. Make sure that all of the tongues are facing out towards the center of the Traffic Calming Product. Use the tongue and groove system to ensure the units interlock snugly, as shown. Use a hammer if necessary to align the modules.



Snugness of the modules is critical at all times as is utilizing the chalk line as a guide for straightness.

**Important** The first row of modules must be secured with bolts and anchors before proceeding to the next row.



**NOTE:** If you are installing an odd number of speed cushions based upon roadway width, start with the center cushion and work outward toward the roadway edge. Once installed, then remeasure the cushion gap spacing for the adjacent cushions. Mark the locations with chalk or painted lines as in STEP 2.

If you are installing speed humps or tables, start with the roadway pavement edge and proceed to install from the outer road edge toward the center line. Then from that center line to the outer road edge opening completed lane for traffic to proceed.



Each module has the part number on the surface module edge.

5. **Pre-mark the drill bit to 8-in. (20 cm) deep, with tape or paint.** Standing on the first corner module, use the hammer drill and a 9/16-in. (14 mm) diameter x 12-in. or 18-in. (30 cm or 46 cm) or longer drill bit to drill through the existing module holes of the first row. To install standard 7-in. (18 cm) anchors, drill 8- to 9-in. (20 to 23 cm) deep into the asphalt. To install 4-in. (10 cm) anchors, drill 5- to 6-in. (13 to 15 cm) deep. Four-inch (10 cm) anchors are best for use in concrete surfaces or in snowbelt areas.

Standing on the module being drilled greatly reduces module movement while drilling as well as when removing drill bit. Once all 6 holes are drilled, move on and repeat.

6. **IMPORTANT.** Using a high performance air compressor, make sure all the holes are clear of all dust and debris before installing the anchors. Remeasure the depth of the holes. You can use a bolt as a depth gauge. The compressor must be able to maintain 90 PSI (6.2 Bar).
7. Once the above is done, wearing protective glasses, insert 2-3 squirts of adhesive into each hole. Then, using the T-bar anchor tool and hand-held sledge hammer, insert the plastic anchors into each hole until flush. Then, quickly insert a bolt and washer assembly and install them using the high speed drill and an 11/16-in. (6 mm) socket. Ensure that the bolts are snug, but do not over-tighten them. The bolt head should always sit below the rubber surface. If the high speed socket keeps spinning, take a hammer and hit the bolt head until it moves below the surface of the rubber. Using the hammer will not damage the bolt or anchor.



**NOTE:** There may be times when the anchor or bolt will not go deep enough into the drilled hole. Should this occur, remove the combo and re-clean for debris. Remeasure for depth using a bolt. If needed, re-drill as either the hole was not deep enough or the adhesive hardened.

Do not over-drill depth as this would require additional adhesive mixture. Reaming the drilled hole is not advisable, but may be needed to assist in easing any resistance with anchor insertion.



**NOTE:** APPLY THE ADHESIVE IN ALL SIX HOLES OF THE PERIMETER MODULES ONLY. Interior modules DO NOT require adhesive, as they will be held in place not only by the tongue and groove system, but also by the perimeter modules, which include adhesive.

For example, for any product that is 7-ft. (2.1 m) long, no matter the width, all six holes in every module would require adhesive. For speed cushions, speed humps, and speed tables of 10.5 ft., 14 ft., 17.5 ft., 21 ft., 24 ft. (3.2 m, 4.3 m, 5.3 m, 6.5 m, 7.3 m) or longer, no matter the width, only the perimeter module holes require adhesive.

Each speed cushion, speed hump, and speed table includes the appropriate amount of anchor adhesive in addition to lag bolts, washers, and anchor installation hardware.

8. Once you have bolted the first row to the ground, you can begin assembling the next row of modules. Using a 10-lb (4.5 kg) sledge hammer, knock the row snug to the first row. Continue to assemble and connect the additional rows, while at the same time drilling out the holes for the rows that have been completed. Continue installing the rows until half the width of the street is completed. Then, proceed to the other half. This sequence allows traffic to flow through half the street at any given time. If you're installing speed cushions, complete the entire product before moving on to next.



## Lane Closure on a Two-Lane Road (Two Flagger Operation)

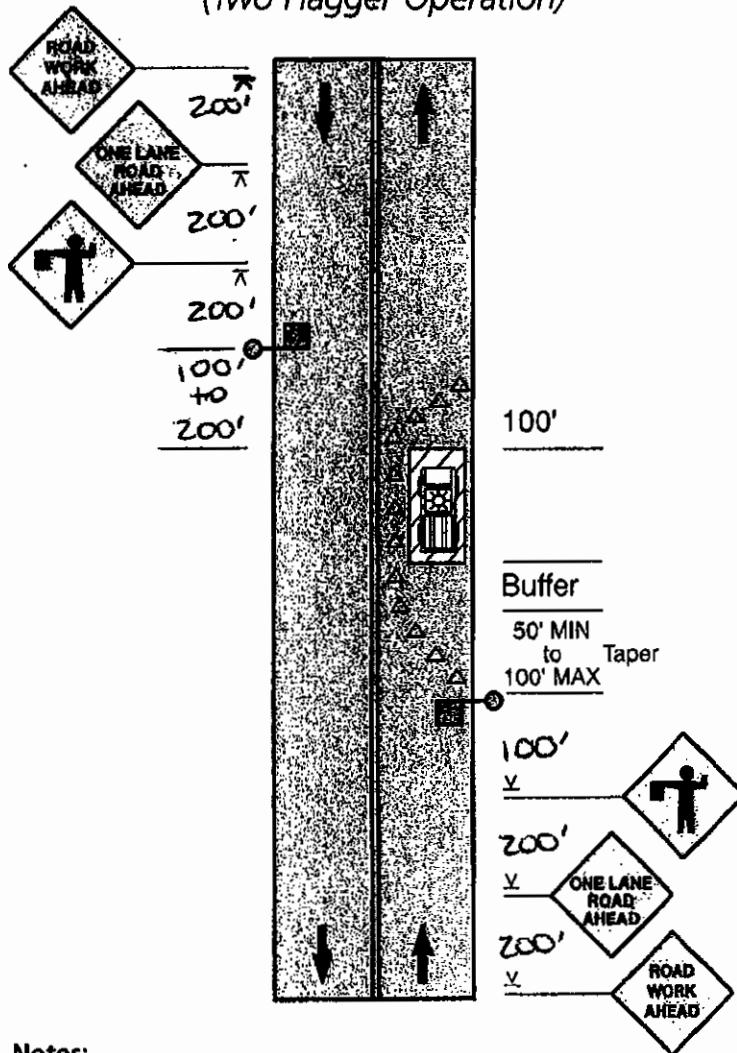

### Notes:

1. For low-speed (35 MPH or less) conditions, a 200-foot sign spacing may be used. For speeds of 40 to 50 MPH a 350-foot sign spacing may be used.
2. For operations of 60 minutes or less, the "Road Work Ahead" sign may be omitted.
3. Generally, the use of "End Road Work" signs is optional for short duration work sites. However, if the work site, itself, is long, or the beginning and end of the work site are not visible to a driver passing through it, then "End Road Work" signs should be used.



# Speed Cushions

# V3 Series Style

All modules have patented interlocking tongue and grooves. Assists with installed cushion impact stability. Reduces installation time.



All cushions include installation hardware and anchor adhesive.

## V3 Speed Cushion

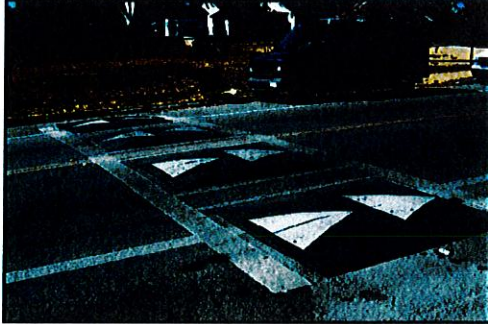

### SPECIFICATIONS

#### Dimensions of the tongue and groove modules:

- Width: 18" (+/- 1/16")
- Length: 42" (+/- 1/8")
- Thickness: 3" (+/- 1/8")

#### Dimensions of the Cushions are changeable by

Width: 18" increments

#### Standard Dimensions of Speed Cushions

- 7' L x 6' W x 3" H • 8 modules
- Entrance and exit gradient: 1:15 (7%) Lip: .25"
- Side gradient: 1:3 (35%) Lip: .25"

#### Physical properties:

- Material:** Compression molded 100% recycled synthetic and natural rubber composite
- Tensile strength:** minimum 500 psi
- Shore hardness:** minimum 70A
- Specific gravity:** 1.1
- Deformation Rate:** None; 100% recovery
- Skid Resistance:** 89 (Dry)

#### Markings: V3 Series

Rubber modules are available in all black, black with large white reflective arrows. Markings are embedded into rubber during manufacturing.

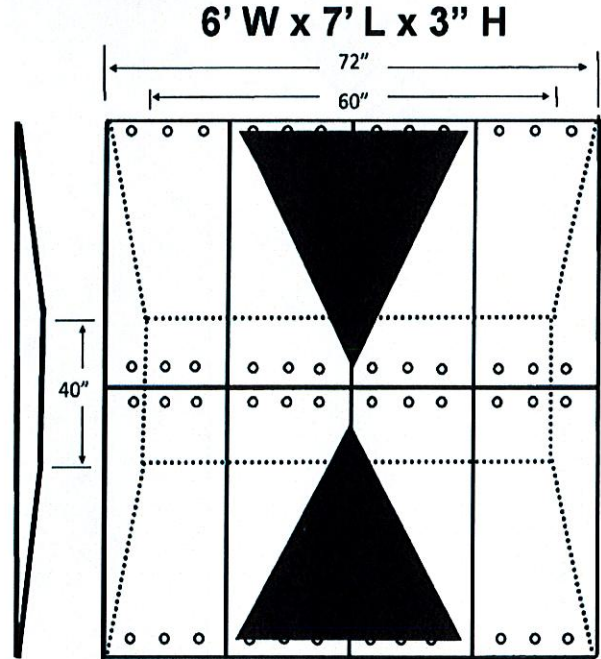

SCV3-070603-TA (Type A)

SCV3-070603-TB

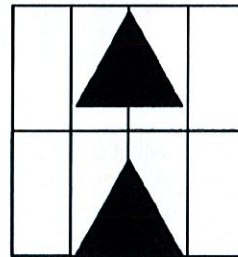

(Type B)

SCV3-070603-TC

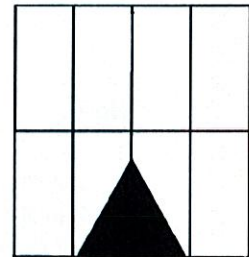

(Type C)

Not Shown: SCV3-070603-TD (Type D) - No Arrows; All Black





SC-V3 - 040816-R1





NC CGIA, Microsoft, Sanitor

**Legend**



-  Speed Cushion
-  Area of Influence

**Nash Street  
Speed Cushion Locations**





**Legend**

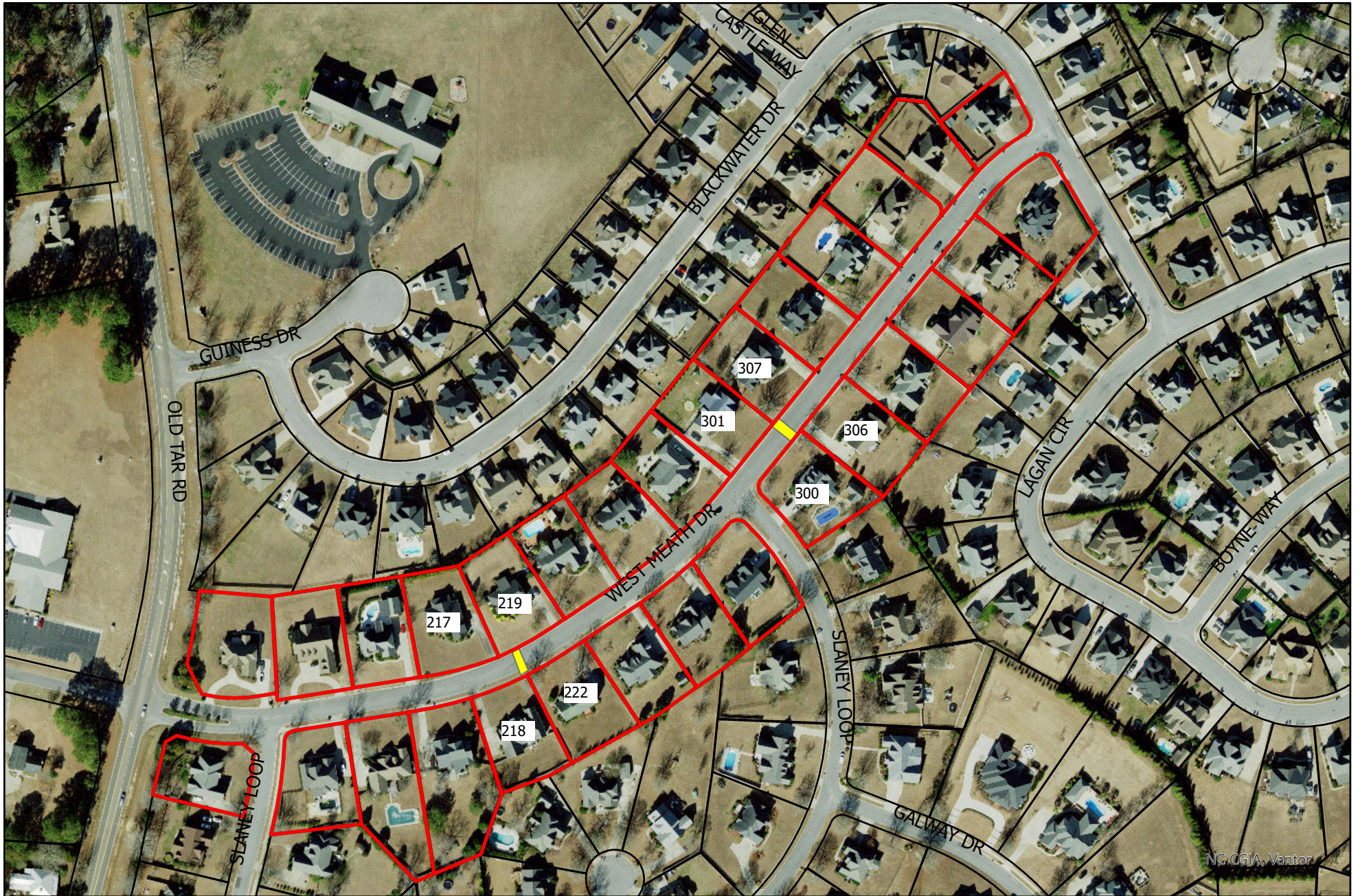

-  Speed Cushion
-  Area of Influence

**Crestline Blvd  
Speed Cushion Location**



NC CGIA, Vantor

### Legend

-  Speed Cushion
-  Area of Influence

## W. Meath Drive Speed Cushion Locations



Cushions to be installed at drainage crossing

Install 2 cushions at each location

**Legend**

 Speed Cushion

**Wildwood Park  
Speed Cushion Locations**

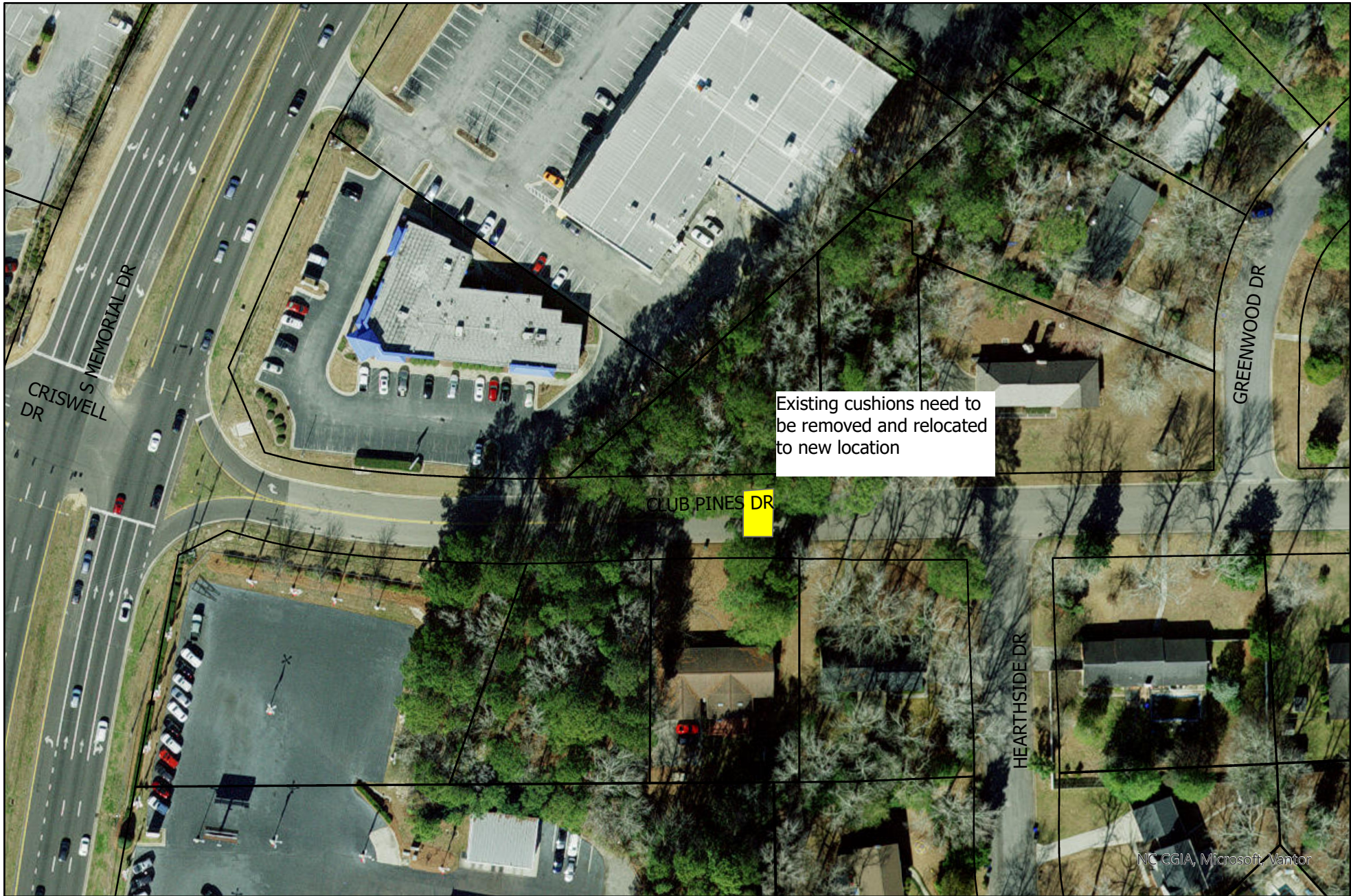

NC CGIA, Microsoft, Vantor

**Legend**

 Speed Cushion

**W. Meath Drive  
Speed Cushion Locations**



Remove existing 3 cushions and reinstall 4 cushions across

Remove existing 3 cushions and reinstall 4 cushions across

NC CGIA, Microsoft, Vantor

# Brownlea Drive Speed Cushion Locations